

JET

Get The Jet Advantage



*World Class
Precision and Quality*

JET Silver Line

A Landmark of Precision

PRECISION MANUFACTURED from the finest NICKEL SILVER and Polished to a Magnificent Silver Finish! A landmark in key manufacturing.

Over 180 numbers, coined, embossed and designed to create the appearance of the originals!

Offering Regular and Sectional keys from...

ARROW	BEST	CORBIN RUSSWIN
DIEBOLD	FALCON	HHM
KWIKSET	LeFEBURE	MEDECO
MOSLER	SARGENT	SARGENT & GREENLEAF
SCHLAGE	YALE	YORK

PERFECT for Master Keying and Duplication!

GUARANTEED to be consistently Superior to the Original Manufacturers productions!



SEE PAGES
23-27
FOR COMPLETE
DETAILS

JET PersonalLine™

YOUR NAME IS THE KEY!



SEE PAGE
57 FOR
DETAILS

Have YOUR shop's name and phone number on all the top selling key blanks you sell!

Have your customers come back to you to have a key duplicated. Every time your customers use their key they will see your shop's name. Thousands of ad impressions for years and years.



A World of Precision and Quality

Choose TET

For Fun



For Security



For Accuracy



QUALITY Is Our Key

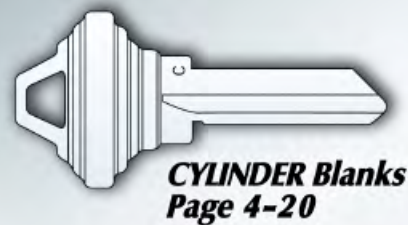

CYLINDER Blanks
Page 4-20



FLAT STEEL Blanks
Page 20



"250" BIN PACKS & 500 PACKS Page 21



PLASTIC HEAD COLOR Blanks
Page 22



JET SILVER LINE
Page 23-27

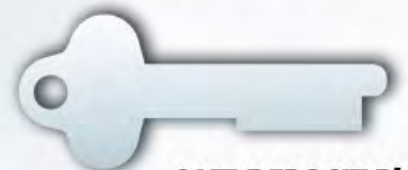

SAFE DEPOSIT Blanks
Page 28-29



DOMESTIC AUTO Blanks
Page 30-36



FOREIGN AUTO Blanks
Page 37-43



PLASTIC BOW & VATS AUTO Blanks
Page 44-48



HIGH SECURITY Blanks
Page 48



TRANSPONDER KEY BLANKS and TRYOUT KEYS
Page 49-53



TRANSPONDER HARDWARE and SOFTWARE
Page 54-55



NEUTER BOW Blanks
Page 56



UNI-BOW Line
Page 57



DITTO+ Line
Page 57



PERSONAL Line
Page 57



BIG-BOW Line
Page 58



HOTEL / MOTEL Blanks
Page 58



Brass KEY TAGS
Page 58



KEY MACHINES and CUTTER WHEELS
Page 59-61



JET DISPLAYS and KEY ASSORTMENTS
Page 62-63

KEY BLANK CROSS REFERENCE TABLES
Page 64-91

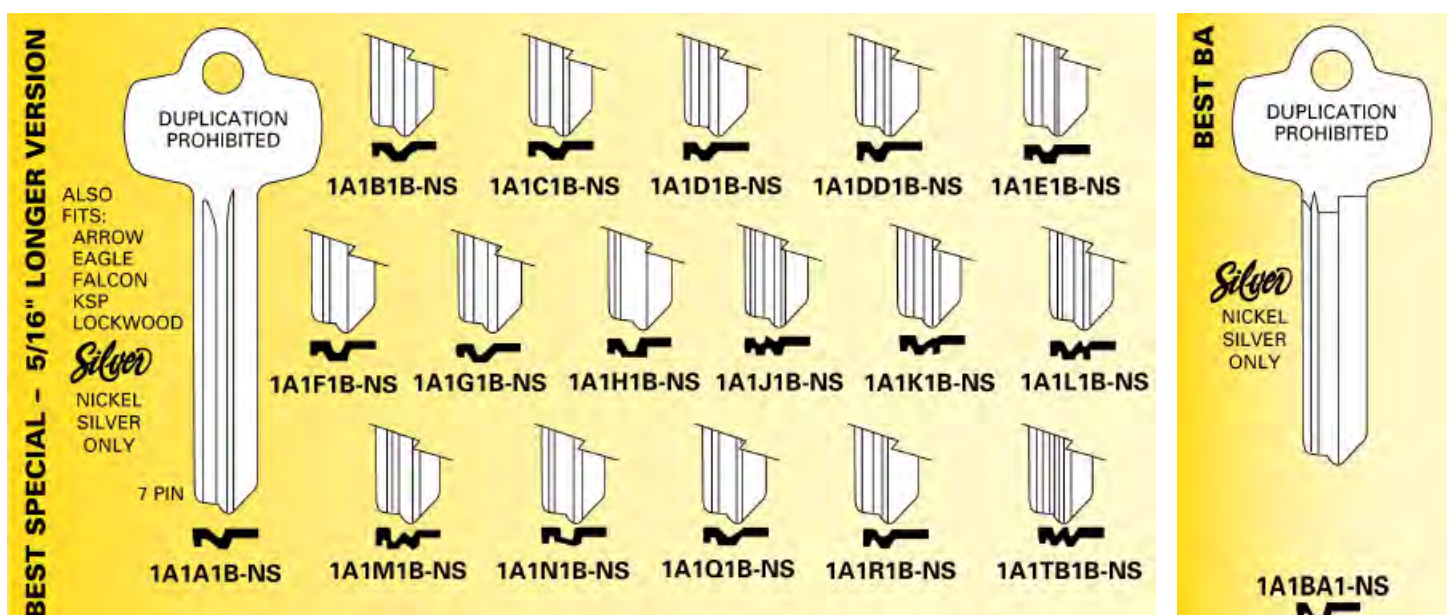
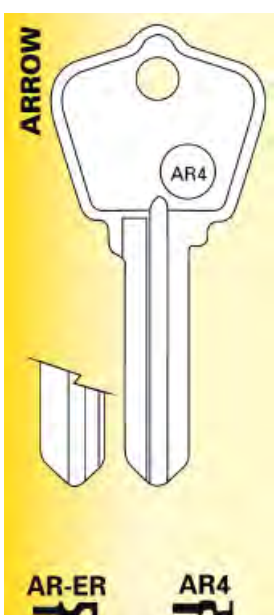
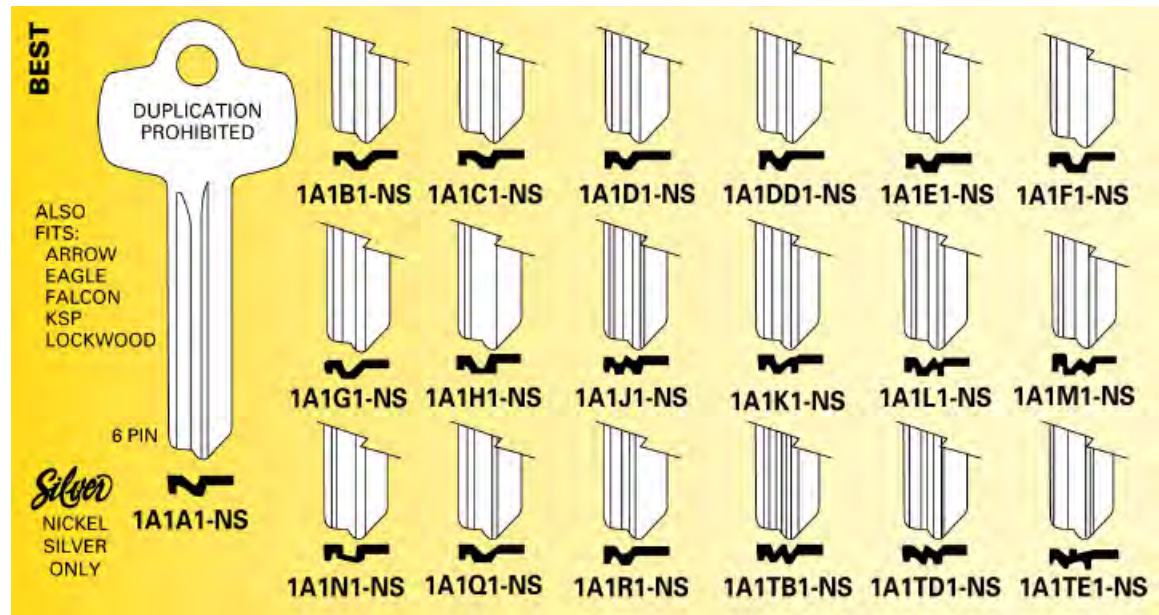
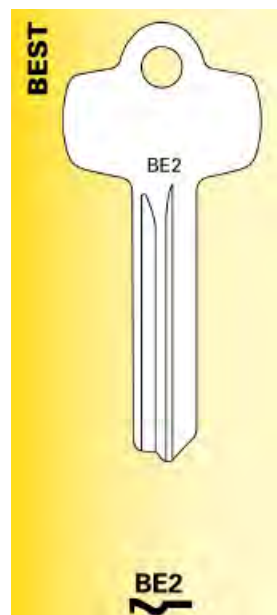
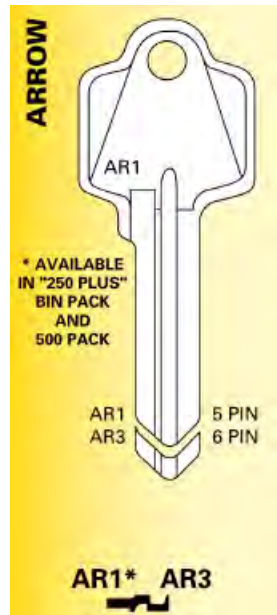
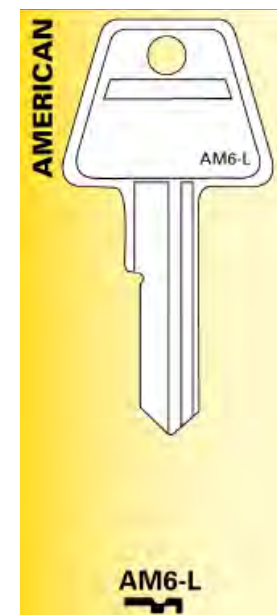
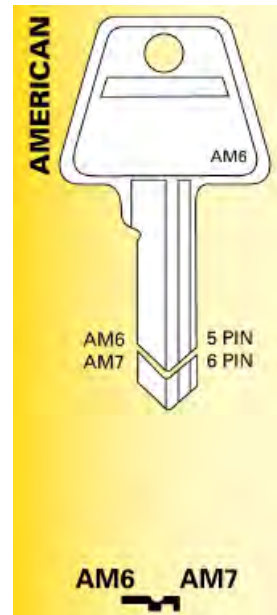
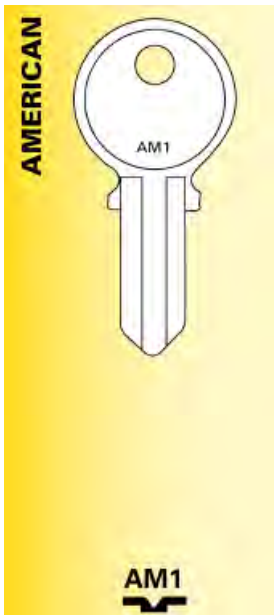
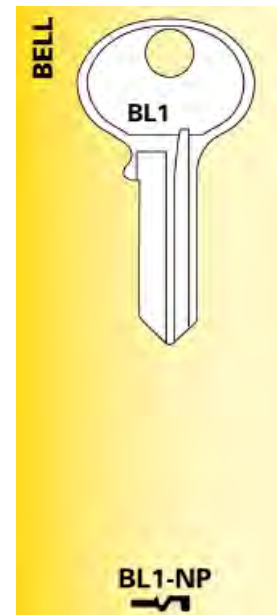
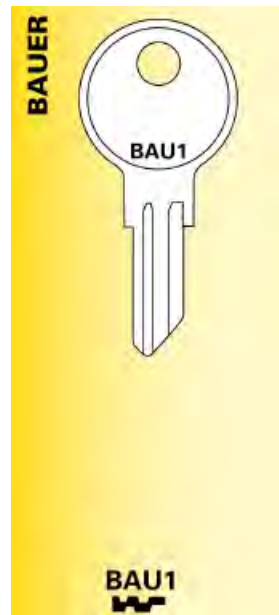
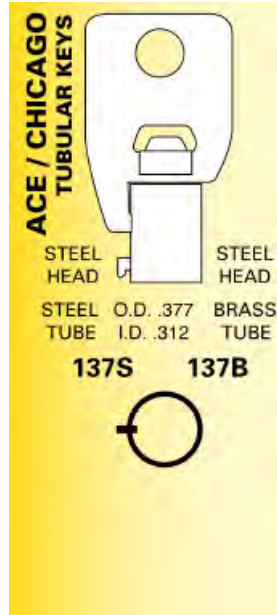
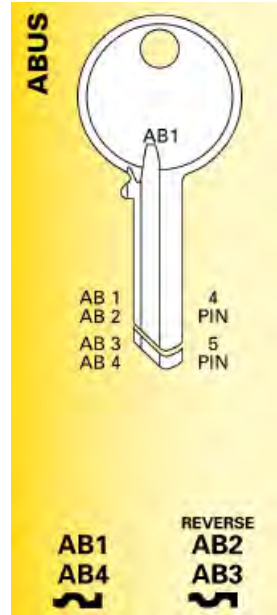

BOMMER (HUDSON)
HL2

CCL
CO10
CO17
CO19
5 PIN
6 PIN
7 PIN

CCL
CO54 1/2

CCL
CCL1-NP

CEMEX
E42
DN
E42DN

CHICAGO
KP9

CLINTON
CL1

CLOPAY
CLP1-NP

CORBIN
CO1
CO2
5 PIN
6 PIN

CORBIN
CO3
CO4
CO33
5 PIN
6 PIN
7 PIN

CEMEX
T3NR

CHANTRELL-LOCKWOOD
L6M
L6M
L7M
6 PIN
7 PIN

CHANTRELL-LOCKWOOD
L6MR
L6MR
L7MR
6 PIN
7 PIN

CHICAGO
CG1
CG2
CG4

CHICAGO
CG16
CG22

CORBIN
CO5
CO6
5 PIN
6 PIN

CORBIN
CO7
CO36
CO37
5 PIN
6 PIN
7 PIN

CORBIN
CO68
CO26
5 PIN
6 PIN

CORBIN
CO51
CO52
6 PIN

CORBIN
SK1
CO62
SK4
5 PIN
6 PIN
7 PIN

CHICAGO
K100M
K101
K102
K103
K104

CHICAGO
K101H-NP
K102H-NP
K103H-NP
K104H-NP
SECURITY DIMPLE ON REVERSE OF BLADE

CHICAGO
KP1
KP2

CORBIN
CO87
CO88
L01EH
5 PIN
6 PIN
7 PIN

CORBIN
CO89
CO90
L01ABM
5 PIN
6 PIN
7 PIN

CORBIN
CO91
CO92
CO94
CO95
CO98
CO99
6 PIN

CORBIN
CO97

TET Cylinder Key Blanks

CORBIN



LOCK OUT KEY

CO-LO
(059AD-6)

CORBIN



057AD-6-NP

CORBIN

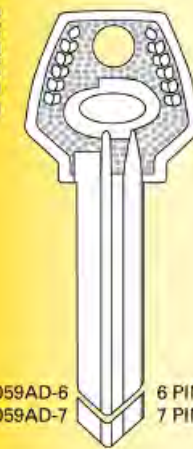

059AD-6 6 PIN
059AD-7 7 PIN

059AD-6 059AD-7

CORBIN RUSSWIN



CR 45
CR 46

5 PIN
6 PIN

CR45 CR46

CORBIN RUSSWIN



CR 87
CR 88

5 PIN
6 PIN

CR87 CR88

CORBIN RUSSWIN



Silver
NICKEL SILVER ONLY

59A1-6-NS

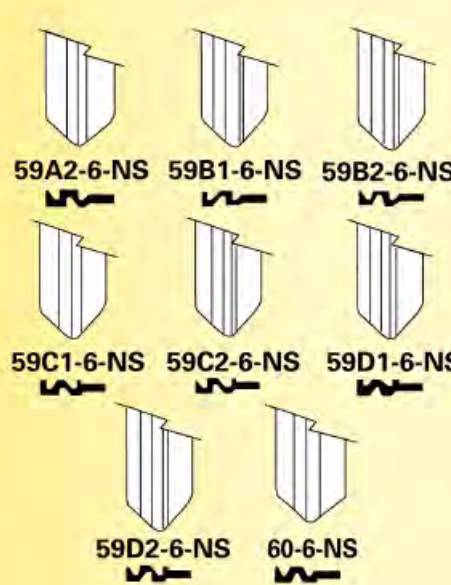

59A2-6-NS 59B1-6-NS 59B2-6-NS
59C1-6-NS 59C2-6-NS 59D1-6-NS
59D2-6-NS 60-6-NS

CORBIN RUSSWIN



Silver
NICKEL SILVER ONLY

57A1-6-NS



57A2-6-NS
57B1-6-NS
57B2-6-NS

CORBIN RUSSWIN



CR 91

6 PIN

CR91

CORBIN RUSSWIN



CR-L4
CR-L4

5 PIN
6 PIN

CR-L4-5 CR-L4-6

CORBIN RUSSWIN



CR L41-6

6 PIN

CR-L41-6

CORBIN RUSSWIN



Silver
NICKEL SILVER ONLY

D2-6-NS D1-6-NS

CORBIN RUSSWIN



Silver
NICKEL SILVER ONLY

D3-6-NS D4-6-NS

DEXTER



DE6
DE8

5 PIN
6 PIN

* AVAILABLE IN "250 PLUS" BIN PACK

DE6* DE8

DEXTER



LOCK OUT KEY

DE-LO (DE6)

DOMINION

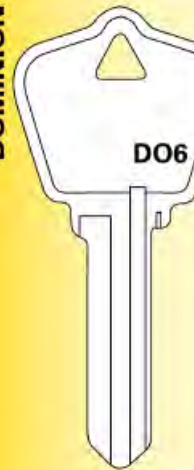

D06-NP

DOMINION



P54F

P54F-NP

DOMINION



TET S54F

S54F

CORBIN RUSSWIN H-SERIES

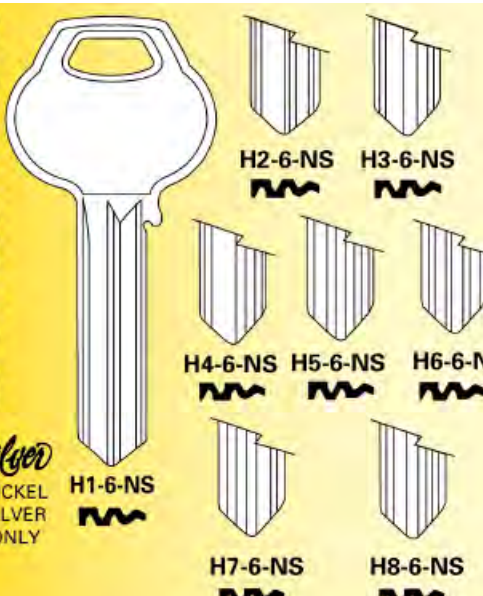

Silver
NICKEL SILVER ONLY

H1-6-NS
H2-6-NS H3-6-NS
H4-6-NS H5-6-NS H6-6-NS
H7-6-NS H8-6-NS

CORBIN RUSSWIN

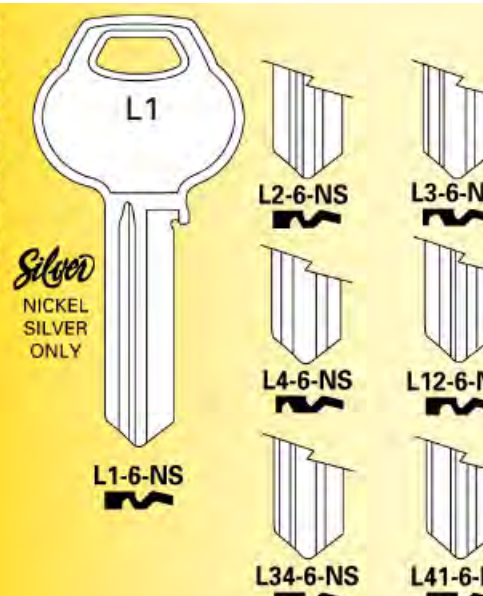

Silver
NICKEL SILVER ONLY

L1
L1-6-NS
L2-6-NS L3-6-NS
L4-6-NS L12-6-NS
L34-6-NS L41-6-NS

CORBIN RUSSWIN



Silver
NICKEL SILVER ONLY

77-6-NS

EAGLE



EA27

EA27

EAGLE



EA47

EA47

ESP



ES1

BACK RADIUS MILLED

ES1

ESP



ES8

ES8 ES8M

ESP



ES9

BACK RADIUS MILLED

ES9

Cylinder Key Blanks TET

FALCON



FA1 5 PIN
FA2 6 PIN

FA1 FA2 FA3

FALCON

Silber
NICKEL SILVER ONLY

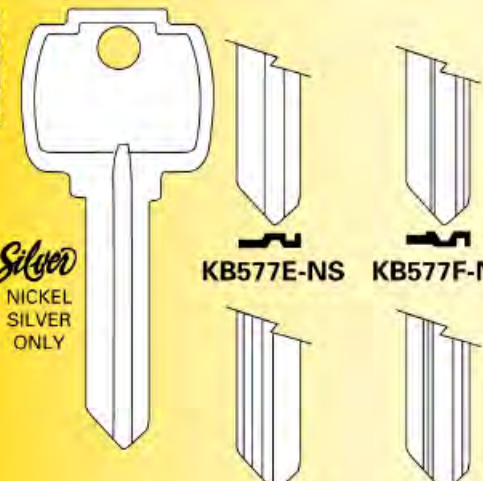

KB577E-NS KB577F-NS
KB577G-NS KB577J-NS

FANAL



R55

FERUM



M1R

ILCO



IN1

ILCO



IN3

ILCO



IN8

ILCO



IN18

ILCO



IN20

FORT LOCK



54G L54G

FRATELLI FACCHINETTI



FF1

FF1-NP

GLOBE PADLOCK



CO2L

HARLOC



HRI

HR1

HARLOC



HR2

HR2

ILCO



IN28 IN33

ILCO



IN29

ILCO



IN35

ILCO



M1-TG

ILLINOIS



IL1

HAWORTH



HK1

HK2 HK3 HK4

HOME DEPOT



EM1

STORM DOOR

EM1

HOME DEPOT



EM1R

STORM DOOR

EM1R

HUDSON, AUTH



HL1

HL1

HUDSON



HL1-M

HL1-M

ILLINOIS

NICKEL PLATED ONLY



IL11

IL11-NP

ILLINOIS



IL210

IL210M IL220

ILLINOIS



IL260

IL260

ILLINOIS



IL360

IL360

ILLINOIS



IL510

IL510 IL610

TET Cylinder Key Blanks

KEIL

K1 K2

KWIKSET

1063KW-BR
1063KW-NP

KWIKSET

8260KW-NS

KWIKSET

CO-KW1

KWIKSET

KW1-IMP

Cylinder Key Blanks TET

LOCKWOOD

O4KA L37

LORI

LO80-5

Imported Locks LSDA

EZ1-NP

MAG

A191-NP A192-NP

MASTER

M1+*

* AVAILABLE IN "250 PLUS" BIN PACK

KWIKSET

KW1-JET*
KW1-JET-NP

* AVAILABLE IN "250 PLUS" BIN PACK

KWIKSET

KW1+
KW1+-NP

KW1 IS AVAILABLE IN...

- Groovy Key Patterns
- Color Plastic Bow
- "250 Plus" Bin Pack and 500 pack

KWIKSET

KW5 KW6

KWIKSET

KW9-RT-NP

MASTER

M1

M1 IS AVAILABLE IN...

- Groovy Key Patterns

Master Type Imported Padlocks

MASTER

M1-IMP

MASTER

M1-RV

MASTER

M2 M3

KWIKSET

KW9 KW9-NP

KWIKSET

KW10 KW10-NP

KWIKSET

KW11 KW11-NP

KW11 IS AVAILABLE IN...

- Groovy Key Patterns

LOCKWOOD

L1 L4 L5

MASTER

M19

MASTER

M4 M5 M10 M11 M12 M13 M27

5 PIN 4 PIN

MASTER

M900

MASTER

M6000 M7000

5 PIN 6 PIN

MASTER

M6000 M7000

5 PIN 6 PIN

TET Cylinder Key Blanks

MASTER



M6000B
M7000B

5 PIN
6 PIN

M6000B M7000B

MASTER



MA3

MA3

MASTER DEXTER



MD17

MD17

MEDECO



Silber

AIR-5
AIR-6

5 PIN
6 PIN

AIR-5-BR AIR-6-BR
AIR-5-NS AIR-6-NS

MEDECO



Silber

NICKEL
SILVER
ONLY

SKY-5
SKY-6

5 PIN
6 PIN

SKY-5-NS SKY-6-NS

NATIONAL ROCKFORD



RO1

RO1

PAPAIZ



PZ1

PZ1

PHILLIPS



R52

R52

PHILLIPS

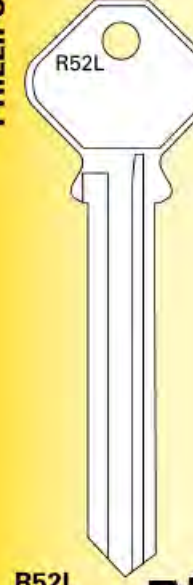

R52L

R52L

PHILLIPS



T32

T32 T32-NP

MUL-T-LOCK®



DO NOT DUPLICATE

Silber

NICKEL
SILVER
ONLY

MTL-06-NS

NATIONAL BROOK



NH1

NH1

NATIONAL ROCKFORD



NA6

NA6

NATIONAL ROCKFORD



NA14

NA14
NA12

4 PIN
5 PIN

NA12 NA14

NATIONAL ROCKFORD



NA24

NA24

PREFER



PR7

PR7

PUNDRA



PU1

PU1

RUSSWIN



RU1

RU1

RUSSWIN

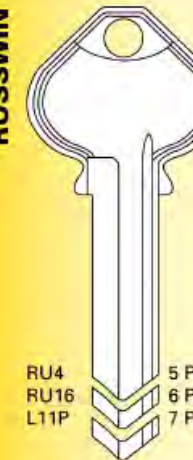

RU4
RU16
L11P

5 PIN
6 PIN
7 PIN

RU4 RU16 L11P

RUSSWIN



RU18

RU18
RU18 1/2
L11PZ

5 PIN
6 PIN
7 PIN

RU18 RU18 1/2 L11PZ

NATIONAL ROCKFORD



D4300

D4300

NATIONAL ROCKFORD



D4301

D4301

NATIONAL ROCKFORD



D8780
D8783
D8787

4 PIN
5 PIN
6 PIN

D8780 D8783 D8787

NATIONAL ROCKFORD



D8781
D8784
D8788

4 PIN
5 PIN
6 PIN

D8781 D8784 D8788

NATIONAL ROCKFORD



D8782
D8785
D8789

4 PIN
5 PIN
6 PIN

D8782 D8785 D8789

RUSSWIN



RU19
RU20
L11D41

5 PIN
6 PIN
7 PIN

RU19 RU20 L11D41

RUSSWIN



RU21
RU22

5 PIN
6 PIN

RU21 RU22

RUSSWIN

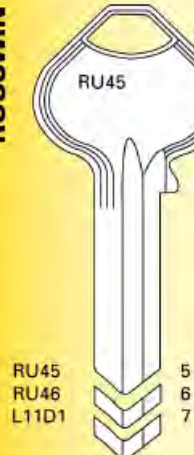

RU45
RU46
L11D1

5 PIN
6 PIN
7 PIN

RU45 RU46 L11D1

SARGENT



Silber

NICKEL
SILVER
ONLY

275LE-NS

SARGENT



Silber

NICKEL
SILVER
ONLY

275RE-NS

Cylinder Key Blanks TET

TET Cylinder Key Blanks

SARGENT



Silver
NICKEL SILVER ONLY

275RF-NS

SARGENT



Silver
NICKEL SILVER ONLY







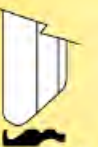
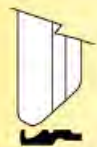

275RG-NS

SARGENT L SERIES

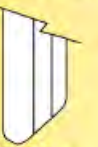
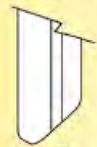

Silver
NICKEL SILVER ONLY

6275LA-NS











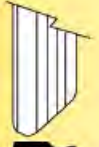

			
6275LB-NS	6275LC-NS	6270LD-NS	6275LE-NS
			
6275LF-NS	6275LG-NS	6270LH-NS	6275LJ-NS
			
6275LK-NS	6275LL-NS	6270LM-NS	6270LN-NS

SARGENT R SERIES



Silver
NICKEL SILVER ONLY

6275RA-NS

			
6275RB-NS	6275RC-NS	6270RD-NS	6275RE-NS
			
6275RF-NS	6275RG-NS	6270RH-NS	6275RJ-NS
			
6275RK-NS	6275RL-NS	6270RM-NS	6270RN-NS

SARGENT

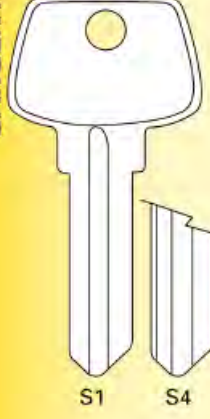

S1

S1 "R"

SARGENT



S4

S4 "U"

S6 S16 L07KMA



5 PIN
6 PIN
7 PIN

SARGENT

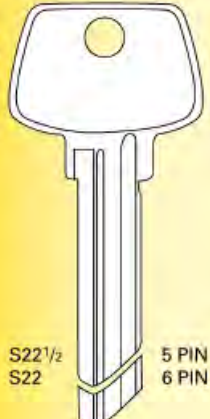

S22^{1/2}
S22

5 PIN
6 PIN

S22^{1/2}, LA S22, LA

SARGENT



S32
S31

5 PIN
6 PIN

S31 S32

SARGENT



S68
S69

5 PIN
6 PIN

S68 S69

SCHLAGE



DO NOT DUPLICATE

Silver
NICKEL SILVER ONLY

100-C-DD-NS

SCHLAGE

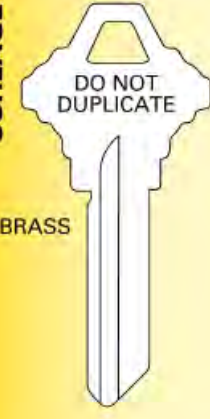

DO NOT DUPLICATE

BRASS

SC1-DD







Cylinder Key Blanks TET

SCHLAGE

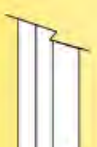

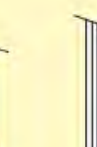
Silver
NICKEL SILVER ONLY

100-C-NS
101-C-NS

			
100-E-NS 101-E-NS	100-F-NS 101-F-NS	101-G-NS	101-H-NS
			
101-EF-NS	101-FG-NS	100-L-NS 101-L-NS	101-CE-NS

SCHLAGE



SC1
SC4

5 PIN
6 PIN

SC1 IS AVAILABLE IN...
• Groovy Key Patterns
• Color Plastic Bow
• "250 Plus" Bin Pack and 500 pack

SC4 IS AVAILABLE IN...
• "250 Plus" Bin Pack

SCHLAGE



SC6

SCHLAGE

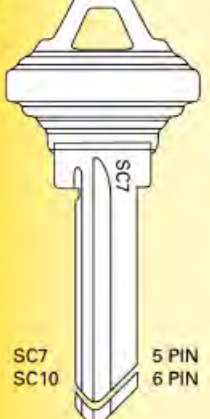

SC7
SC10

5 PIN
6 PIN

SC7 SC10

SCHLAGE



* AVAILABLE IN "250 PLUS" BIN PACK

SC8
SC9

5 PIN
6 PIN

SC8 SC9*
101-E-NP

SCHLAGE



SC19
SC20

5 PIN
6 PIN

SC19 SC20

SCHLAGE



SC22

SCHLAGE



LOCK OUT KEY

SC-LO
(SC19)

SEGAL



5SE3

5SE3

SEGAL



6SE4

6SE4

SEGAL



* AVAILABLE IN "250 PLUS" BIN PACK AND 500 PACK.

SE1+
SE8

5 PIN
6 PIN

SE1+* SE8

SEGAL



SE1

SE1-JET
SE1-NP

<p>SEGAL</p> <p>SE1-M</p>	<p>SHAW WALKER</p> <p>SW1</p>	<p>SLAYMAKER</p> <p>SL1</p>	<p>TAYLOR</p> <p>T3</p>	<p>TAYLOR</p> <p>T7</p>
----------------------------------	--------------------------------------	------------------------------------	--------------------------------	--------------------------------

<p>XL LETTER BOX</p> <p>XL7</p>	<p>YALE</p> <p>8-NP 11-NP 8-NS 11-NS</p>	<p>YALE</p> <p>19-NS</p>	<p>YALE</p> <p>LOCK OUT KEY Y-LO (Y1)</p>	<p>YALE</p> <p>* AVAILABLE IN "250 PLUS" BIN PACK Y1+ Y2 5 PIN 6 PIN</p>
--	---	---------------------------------	--	---

<p>TESA</p> <p>R59</p>	<p>VIRO</p> <p>191B 191 4 PIN 5 PIN</p>	<p>VIRO</p> <p>L191A LR191A</p>	<p>WEISER</p> <p>WR5 WR6 5 PIN 6 PIN WR5 IS AVAILABLE IN... • Groovy Key Patterns • Color Plastic Bow • "250 Plus" Bin Pack</p>
-------------------------------	--	--	--

<p>YALE</p> <p>Y220 4 PIN 5 PIN 6 PIN</p>	<p>YALE</p> <p>NICKEL PLATED ONLY Y1K-NP</p>	<p>YALE</p> <p>Y1M</p>	<p>YALE</p> <p>Y1R</p>	<p>YALE</p> <p>NICKEL PLATED ONLY Y2K-NP</p>
--	---	-------------------------------	-------------------------------	---

<p>WEISER</p> <p>* AVAILABLE IN "250 PLUS" BIN PACK WR3* WR3-NP*</p>	<p>WELCH</p> <p>WE1</p>	<p>WESLOCK</p> <p>* AVAILABLE IN "250 PLUS" BIN PACK WK2*</p>	<p>WILSON BOHANNAN</p> <p>WB1A WB2A WB1B WB2B 5 PIN 6 PIN 5 PIN 6 PIN</p>
---	--------------------------------	--	--

<p>YALE</p> <p>Y4</p>	<p>YALE</p> <p>Y5</p>	<p>YALE</p> <p>Y6 Y52 Y54 4 PIN 5 PIN 6 PIN</p>	<p>YALE</p> <p>Y6E Y52E Y54E 4 PIN 5 PIN 6 PIN</p>	<p>YALE</p> <p>Y78 11GA-NP</p>
------------------------------	------------------------------	--	---	---------------------------------------

JET Cylinder Key Blanks

YALE

Y11

* AVAILABLE IN "250 PLUS" BIN PACK

Y11*

Y12

Y13

Y14

Y103

YALE G SERIES

G

Silver
NICKEL SILVER ONLY

11GA-NS

11GB-NS

11GC-NS

11GD-NS

11GE-NS

11GF-NS

11GMK-NS

11GG-NS

11GH-NS

11GK-NS

YALE

Y221

Y221

YALE

Y227

Y227

YALE S SERIES

SA

Silver
NICKEL SILVER ONLY

11-SA-NS

11-SB-NS

11-SC-NS

11-SD-NS

11-SE-NS

11-SF-NS

11-SG-NS

11-SH-NS

11-SK-NS

11-SM-NS

TUBULAR KEY

137

STEEL HEAD

STEEL HEAD

STEEL TUBE

O.D. .377

BRASS TUBE

I.D. .312

137S

137B

FLAT STEEL KEY BLANKS

0.050
1.3 MM

0.060
1.5 MM

0.060
1.5 MM

0.050
1.3 MM

0.285
7.2 MM

0.310
7.9 MM

0.300
7.6 MM

0.265
6.7 MM

T21

T23

T26

T146

T146-TC



"250 Plus" Bin Packs and 500 Packs

World Class Precision and Quality



"250 Plus" Bin Packs



JET's 250 PLUS bin boxes and Dispenser Rack bring you the combination of functional packaging and convenient storage. Hang on a peg board or wall. Set on the counter or shelf. Either way you'll save time, money and valuable space. The key blanks in the JET 250 PLUS bin pack are the same standard, high quality and precision finished blanks you know and trust. These are the identical keys found in the 50 count box package. JET 250 PLUS bin packs are available in the following key blank numbers...

- | | | | | | |
|------------|------------|------------|-------------|------------|------------|
| AR1-250 | B48-NP-250 | B51-NP-250 | H54-250 | M1-250 | WK2-250 |
| B44-250 | B49-250 | DE6-250 | H60-250 | SC1-250 | WR3-250 |
| B44-NP-250 | B49-NP-250 | H50-250 | H60-NP-250 | SC1-NP-250 | WR3-NP-250 |
| B45-250 | B50-250 | H50-NP-250 | KW1+-250 | SC4-250 | WR5-250 |
| B45-NP-250 | B50-NP-250 | H51-250 | KW1+-NP-250 | SC9-250 | WR5-NP-250 |
| B48-250 | B51-250 | H51-NP-250 | KW1-JET-250 | SE1-250 | Y1-250 |
| | | | | | Y11-250 |

JET 500 PACK

Buy in bulk and save big.

- 500 Pack available in:
- AR1-500
 - KW1+-500, KW1+-NP-500
 - SC1-500, SC1-NP-500
 - SE1-500



JET COOL COLOR Plastic Bow Blanks



World Class Precision and Quality

KWIKSET



KW1-PHC
Kwikset Plastic Head
Color Assortment
2-Blue
1-Red
1 - Green
1 - Yellow

SCHLAGE



SC1-PHC
Schlage Plastic Head
Color Assortment
2-Blue
1-Red
1 - Green
1 - Yellow

WEISER



WR5-PHC
Weiser Plastic Head
Color Assortment
2-Blue
1-Red
1 - Green
1 - Yellow

Also available in one color, 25 keys to a box.
Order by JET number followed by color letter...
i.e. KW1-PHC-B for blue plastic bow.

Cool Color Assortment & Display

Catch your customer's eye and promote sales with JET's Cool Color Display. It comes complete with a 120 piece assortment of the KW1, SC1 and WR5 plastic head color key blanks.

JET number PHC-D-120



World Class Precision and Quality

Precision key blanks made of nickel silver have superior physical and mechanical properties with high tensile strength. This type of key blank has a stronger resistance to corrosion and wear, and presents an attractive appearance with its fine silver polish..

Jet's Silver Line meets the accuracy requirements for both master keying and duplication. For the master locksmith who originates new systems or maintains existing systems, using either accurate wheel type cutters or the new punches, all keys will be perfect every time.

The Silver Line key bows are coined, embossed and designed to create the appearance of the originals. They are polished to a fine finish using a special new process. Look for our black, gold and silver key blank box... it's your guarantee of the finest nickel silver key blanks available today.

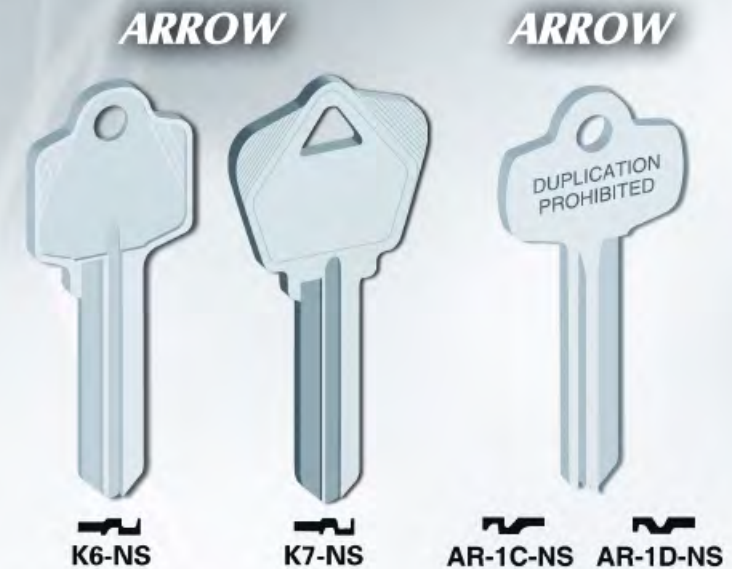

BALDWIN



BAL-1-NS

BEST BA



1A1BA1-NS

BEST COMPOSITES



**1A1D1 & 1A1E1
COMPOSITE**

1A1DE1-NS

**1A1J1 & 1A1K1
COMPOSITE**

1A1JK1-NS



BEST



BEST SPECIAL
5/16" LONGER VERSION

1A1A1-NS	1A1B1-NS	1A1C1-NS	1A1D1-NS	1A1A1B-NS	1A1B1B-NS	1A1C1B-NS	1A1D1B-NS
1A1DD1-NS	1A1E1-NS	1A1F1-NS	1A1G1-NS	1A1DD1B-NS	1A1E1B-NS	1A1F1B-NS	1A1G1B-NS
1A1H1-NS	1A1J1-NS	1A1K1-NS	1A1L1-NS	1A1H1B-NS	1A1J1B-NS	1A1K1B-NS	1A1L1B-NS
1A1M1-NS	1A1N1-NS	1A1Q1-NS	1A1R1-NS	1A1M1B-NS	1A1N1B-NS	1A1Q1B-NS	1A1R1B-NS
1A1TB1-NS	1A1TD1-NS	1A1TE1-NS		1A1TB1B-NS			



CORBIN RUSSWIN

D1-6-NS	D3-6-NS	L1-6-NS	L2-6-NS	L3-6-NS	L4-6-NS	59A1-6-NS	59A2-6-NS
D2-6-NS	D4-6-NS	L12-6-NS	L34-6-NS	L41-6-NS		59B1-6-NS	59B2-6-NS
H1-6-NS	H2-6-NS	H3-6-NS	H4-6-NS	57A1-6-NS	57A2-6-NS	59D1-6-NS	59D2-6-NS
H5-6-NS	H6-6-NS	H7-6-NS	H8-6-NS	57B1-6-NS	57B2-6-NS	60-6-NS	77-6-NS



FALCON



KWIKSET



MEDECO



MEDECO

KB577E-NS	KB577F-NS	8260KW-NS	AIR-5-NS	AIR-6-NS	SKY-5-NS	SKY-6-NS
KB577G-NS	KB577J-NS					



MUL-T-LOCK®

MTL-06-NS



SARGENT L SERIES

6275LA-NS	6275LB-NS	6275LC-NS	6270LD-NS	6275LE-NS
6275LF-NS	6275LG-NS	6270LH-NS	6275LJ-NS	6275LK-NS
6275LL-NS	6270LM-NS	6270LN-NS		



SARGENT

275LE-NS	275RF-NS
275RE-NS	275RG-NS



SARGENT R SERIES

6275RA-NS	6275RB-NS	6275RC-NS	6270RD-NS	6275RE-NS
6275RF-NS	6275RG-NS	6270RH-NS	6275RJ-NS	6275RK-NS
6275RL-NS	6270RM-NS	6270RN-NS		



SCHLAGE



100-C-DD-NS



SCHLAGE

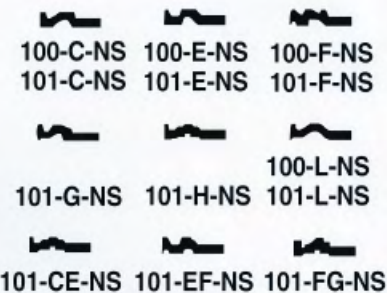

YALE



YALE G SERIES



YALE S SERIES

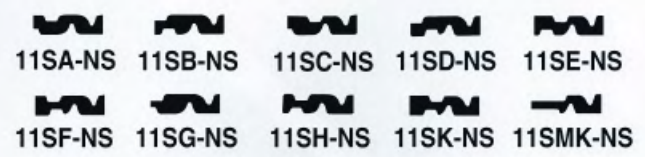

NICKEL SILVER SAFE DEPOSIT KEY BLANKS



DIEBOLD

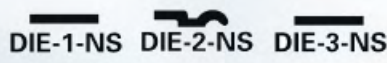

HHM

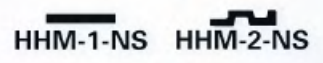

ILCO

ILC-1-NS



KUMAHIRA

SEC-1-NS SEC-2-NS



LeFEBURE

LEB-1-NS LEB-2-NS LEB-3-NS LEB-4-NS LEB-6-NS LEB-7-NS



MOSLER

MOS-1-NS MOS-2-NS MOS-3-NS MOS-4-NS MOS-5-NS

SILVER LINE DISPLAY BOARD

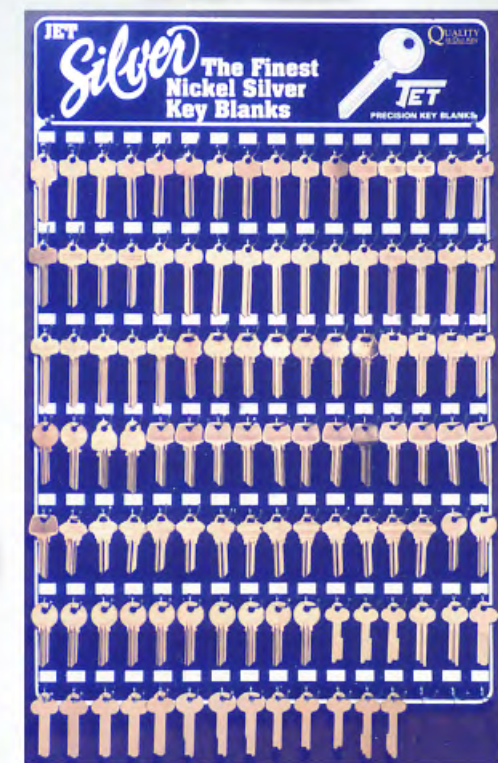

MODEL 4000
 • DURABLE, 1/8-INCH MASONITE
 • MEASURES ONLY 16" X 24"
 • SILVER, GOLD AND BLACK SILVER LINE COLORS



SARGENT & GREENLEAF

S&G-1-NS S&G-2-NS S&G-3-NS



YALE

YAL-1-NS YAL-2-NS YAL-3-NS

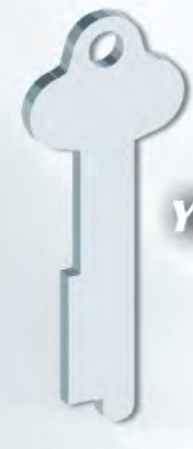

YORK

YOR-1-NS YOR-2-NS



Safe Deposit Blanks

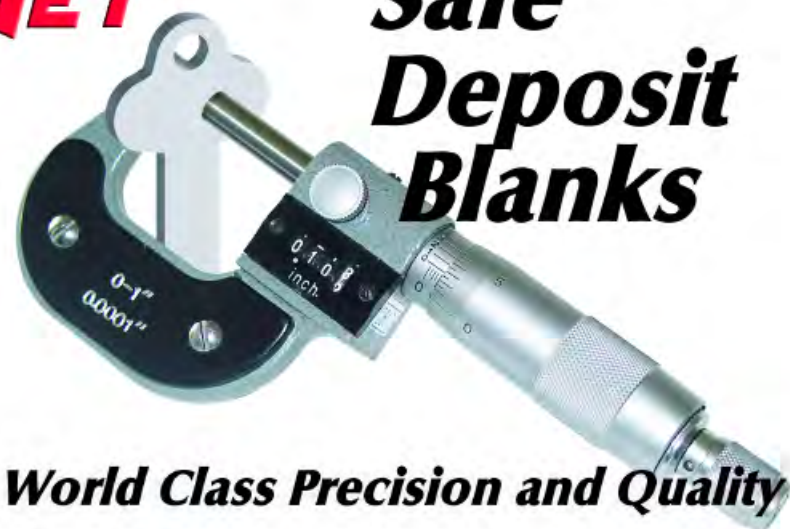

World Class Precision and Quality

Safe Deposit Key Blanks **TET**

DIEBOLD

0.375 9.53 MM
0.050 1.27 MM

NICKEL SILVER ONLY

DIE-1-NS

DIEBOLD

NICKEL SILVER ONLY

DIE-2-NS

LeFEBURE

0.070 1.78 MM
0.315 8.00 MM

NICKEL SILVER ONLY

LEB-6-NS

LeFEBURE

0.070 1.78 MM
0.315 8.00 MM

NICKEL SILVER ONLY

LEB-7-NS

MOSLER

0.060 1.52 MM
0.328 8.33 MM

NICKEL SILVER ONLY

MOS-1-NS

MOSLER

0.060 1.52 MM
0.375 9.52 MM

NICKEL SILVER ONLY

MOS-2-NS

MOSLER

NICKEL SILVER ONLY

MOS-3-NS

DIEBOLD

0.375 9.53 MM
0.055 1.39 MM

NICKEL SILVER ONLY

DIE-3-NS

HHM

0.060 1.52 MM
0.340 8.63 MM

NICKEL SILVER ONLY

HHM-1-NS

HHM

NICKEL SILVER ONLY

HHM-2-NS

ILCO

0.070 1.80 MM
0.330 8.40 MM

NICKEL SILVER ONLY

ILC-1-NS

KUMAHIRA

0.075 1.90 MM
0.436 11.00 MM

NICKEL SILVER ONLY

SEC-1-NS

MOSLER

NICKEL SILVER ONLY

MOS-4-NS

MOSLER

0.060 1.52 MM
0.380 9.65 MM

NICKEL SILVER ONLY

MOS-5-NS

SARGENT & GREENLEAF

0.070 1.78 MM
0.375 9.52 MM

NICKEL SILVER ONLY

S&G-1-NS

SARGENT & GREENLEAF

0.070 1.78 MM
0.375 9.52 MM

NICKEL SILVER ONLY

S&G-2-NS

SARGENT & GREENLEAF

0.070 1.78 MM
0.320 8.12 MM

NICKEL SILVER ONLY

S&G-3-NS

KUMAHIRA

0.075 1.90 MM
0.395 10.00 MM

NICKEL SILVER ONLY

SEC-2-NS

LeFEBURE

0.070 1.78 MM
0.315 8.00 MM

NICKEL SILVER ONLY

LEB-1-NS

LeFEBURE

0.070 1.78 MM
0.315 8.00 MM

NICKEL SILVER ONLY

LEB-2-NS

LeFEBURE

0.070 1.78 MM
0.315 8.00 MM

NICKEL SILVER ONLY

LEB-3-NS

LeFEBURE

0.070 1.78 MM
0.315 8.00 MM

NICKEL SILVER ONLY

LEB-4-NS

YALE

0.085 2.16 MM
0.350 8.89 MM

NICKEL SILVER ONLY

YAL-1-NS

YALE

0.040 1.01 MM
0.300 7.62 MM

NICKEL SILVER ONLY

YAL-2-NS

YALE

0.060 1.52 MM
0.300 7.62 MM

NICKEL SILVER ONLY

YAL-3-NS

YORK

0.385 9.77 MM
0.055 1.39 MM

NICKEL SILVER ONLY

YOR-1-NS

YORK

0.375 9.53 MM
0.050 1.27 MM

NICKEL SILVER ONLY

YOR-2-NS

TET *Domestic Auto Blanks*

World Class Precision and Quality



Domestic Auto Key Blanks **TET**

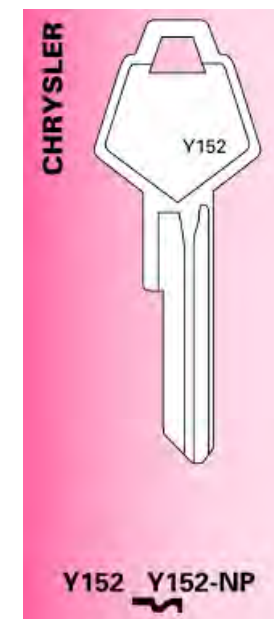
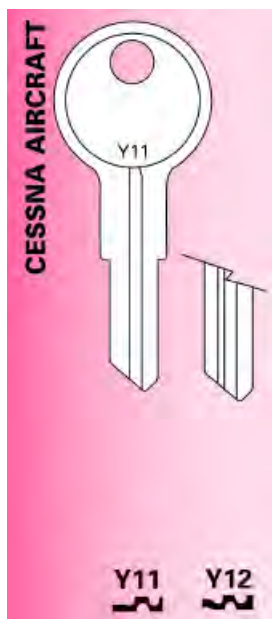
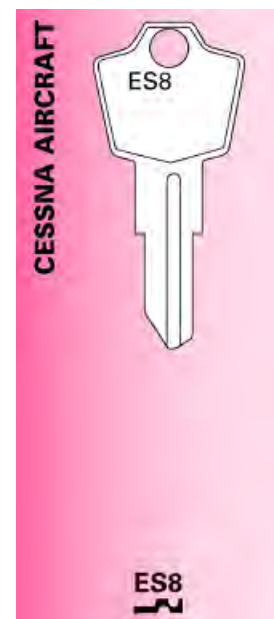
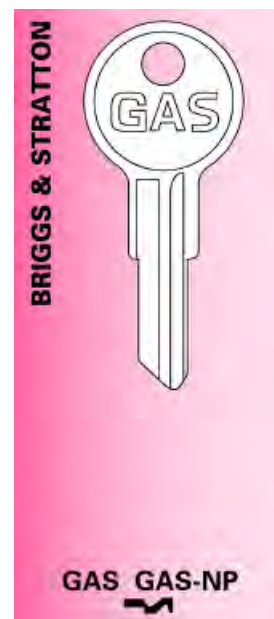
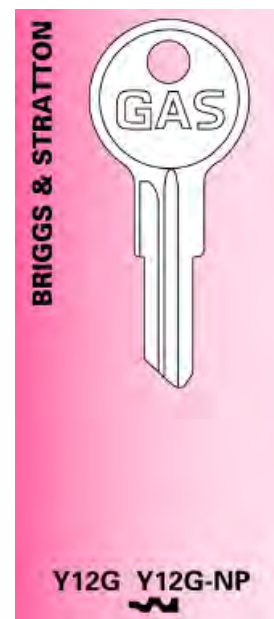
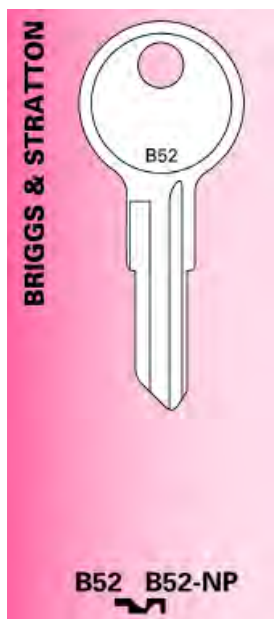
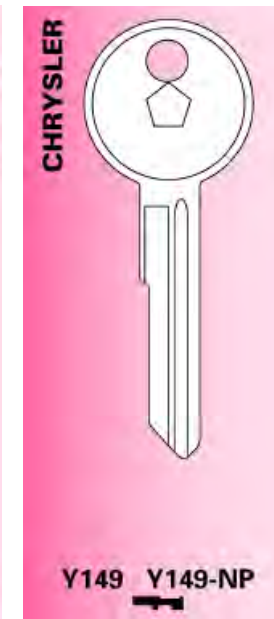
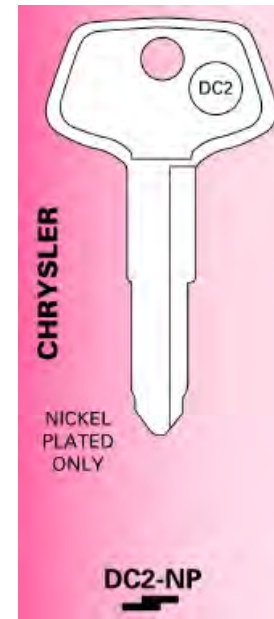
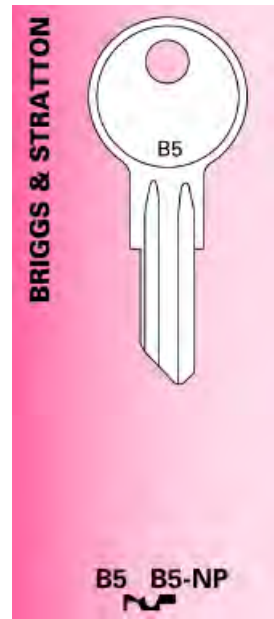
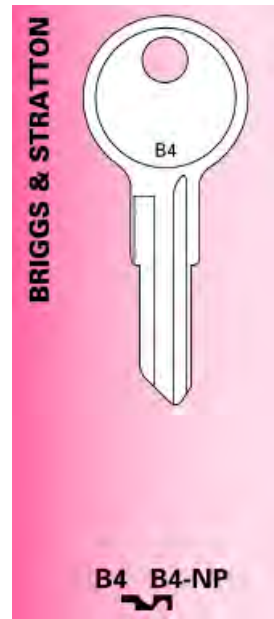
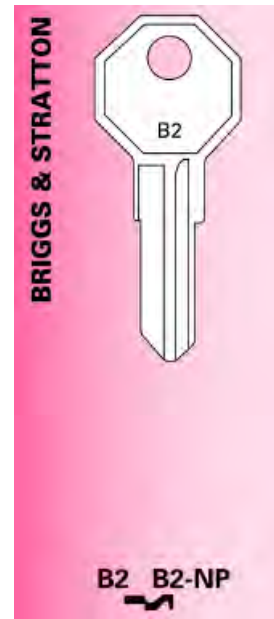
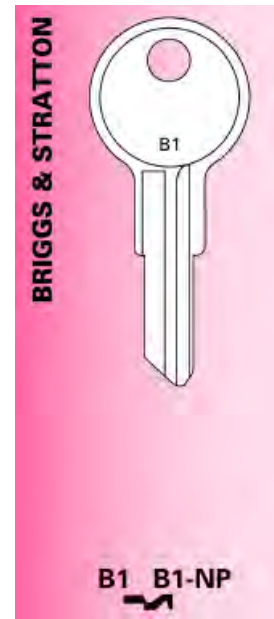
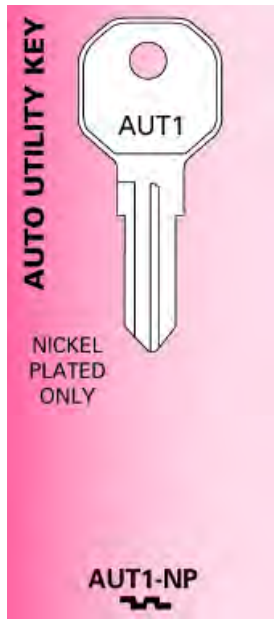
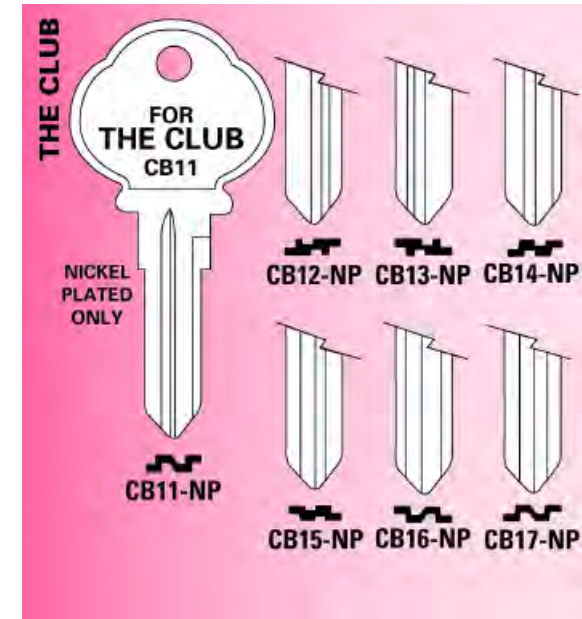
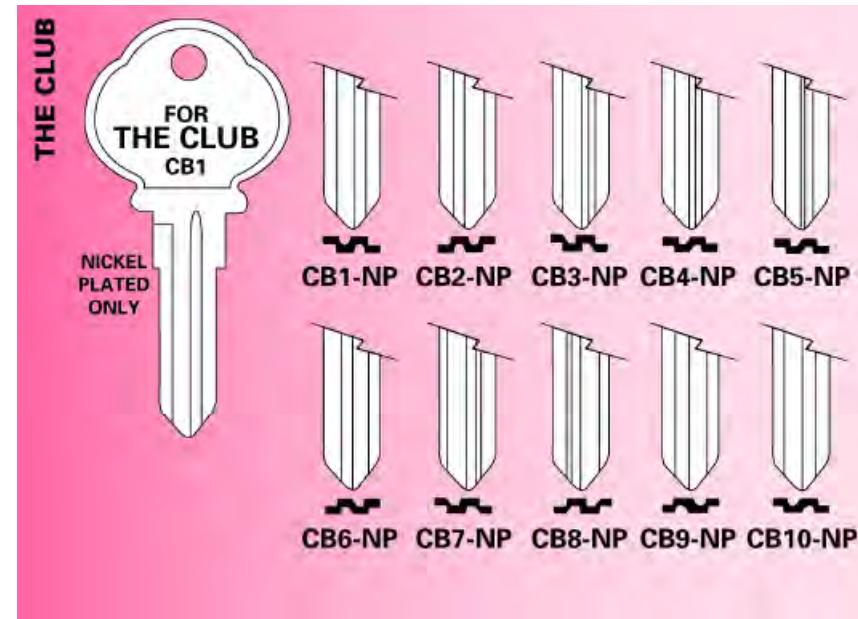

TET Domestic Auto Key Blanks

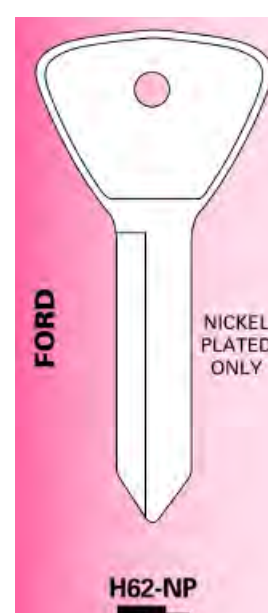

Domestic Auto Key Blanks TET

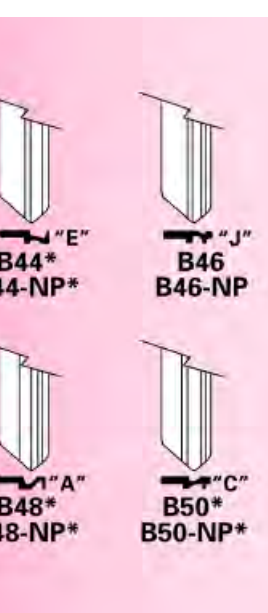
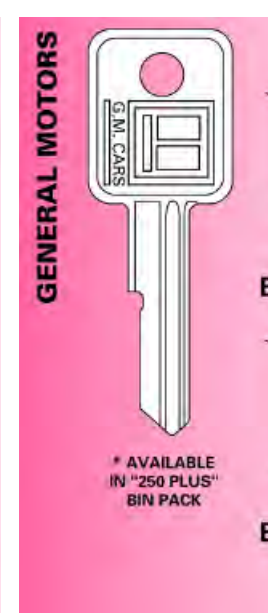
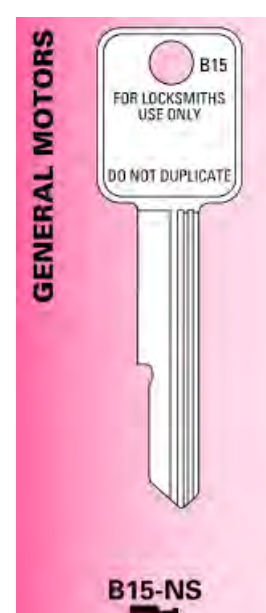
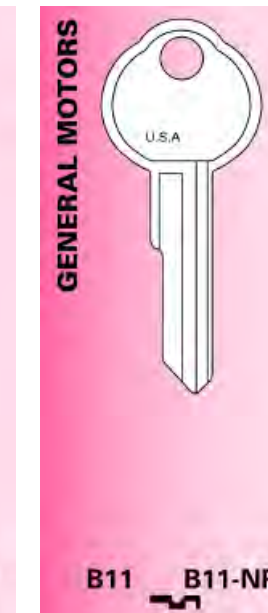
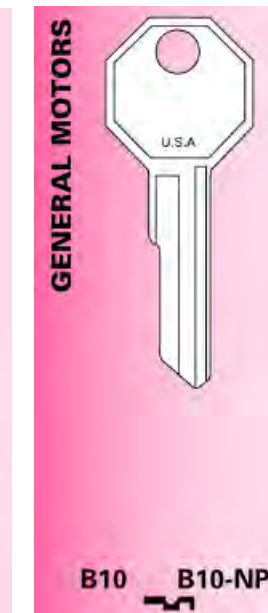
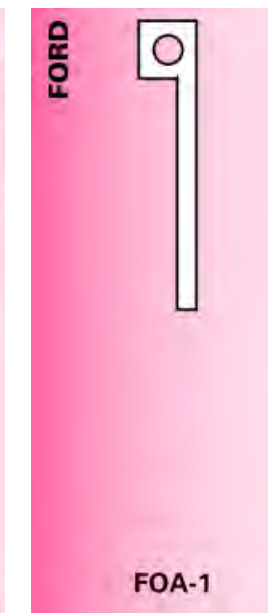
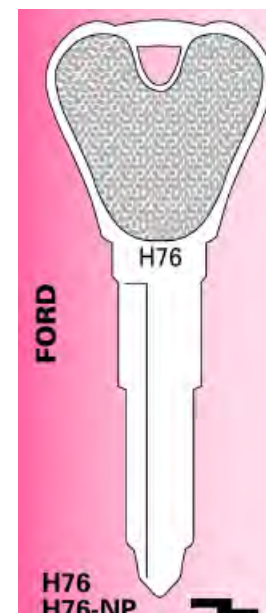
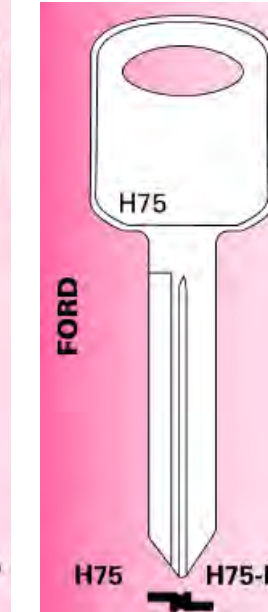
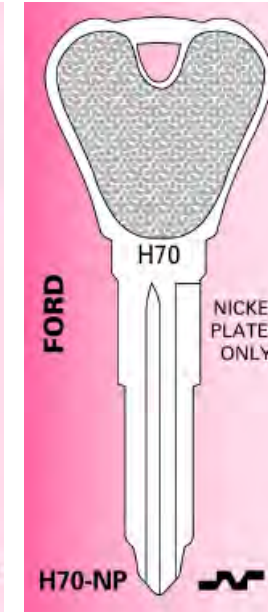

TET Domestic Auto Key Blanks

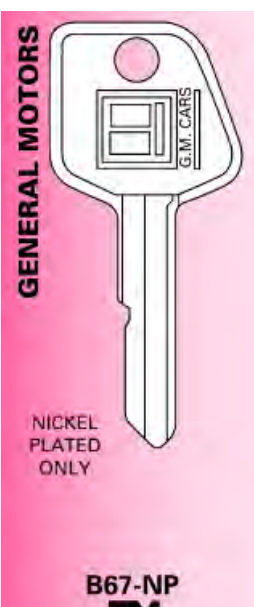
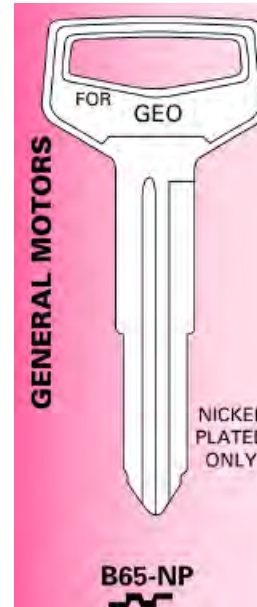
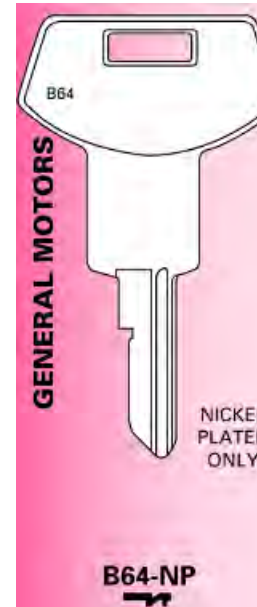
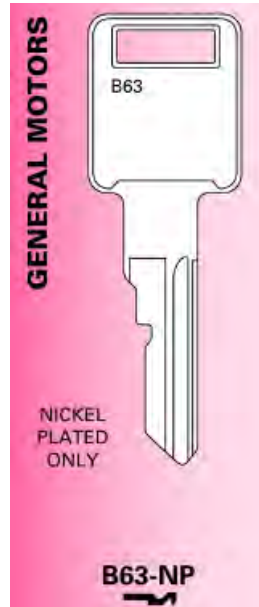
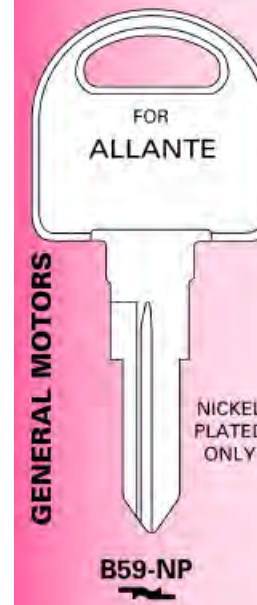
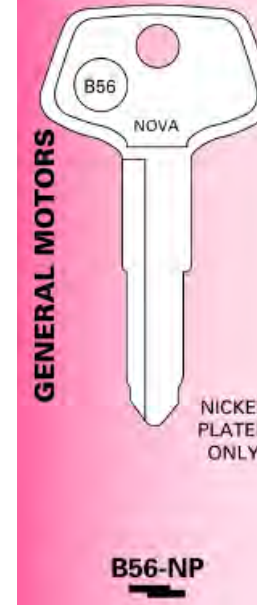
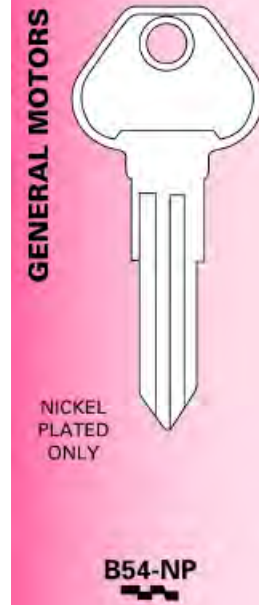

Domestic Auto Key Blanks TET

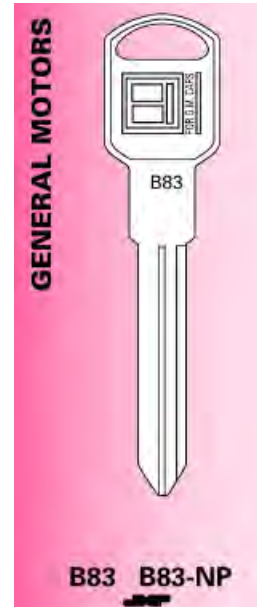
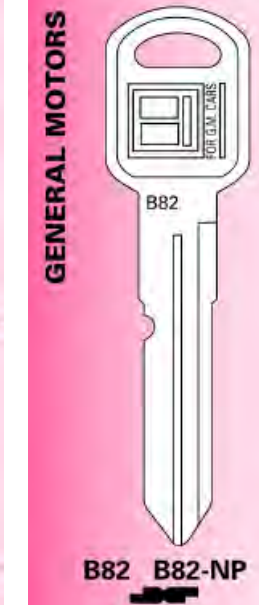
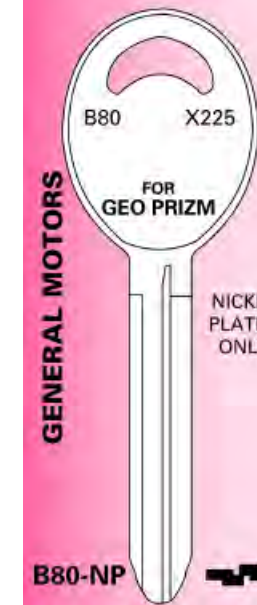
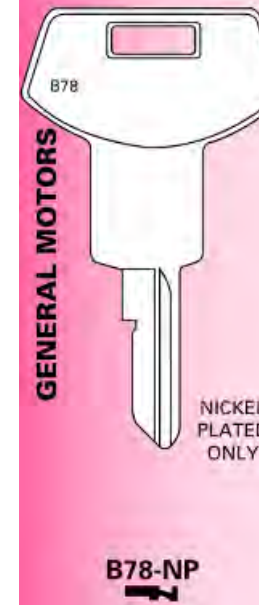

TET Domestic Auto Key Blanks

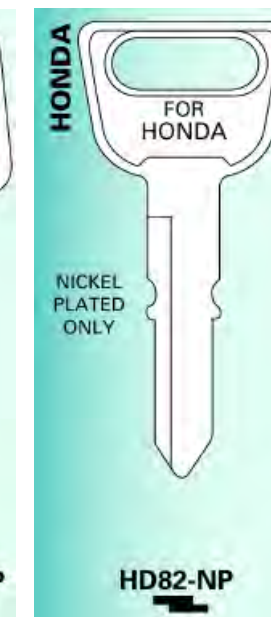
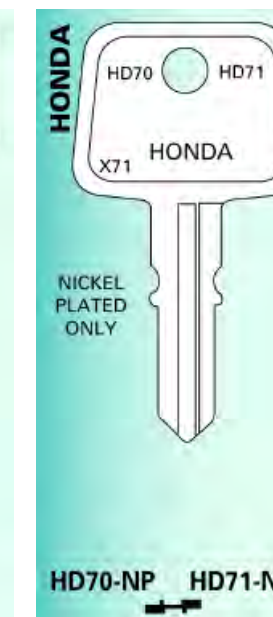
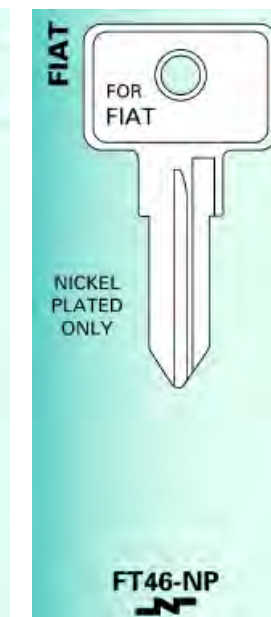
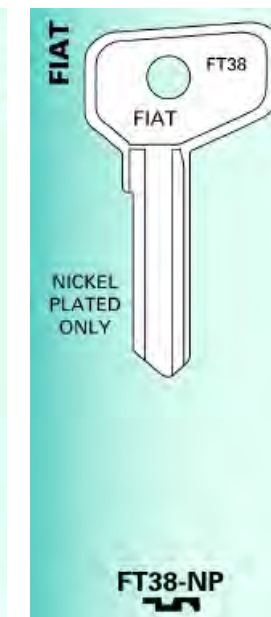
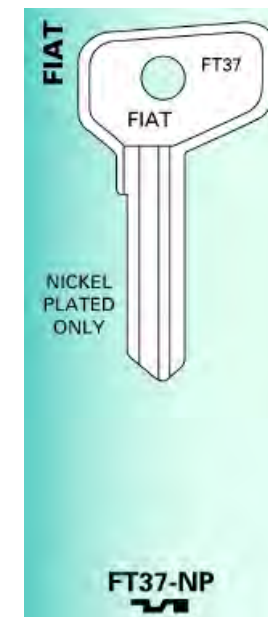
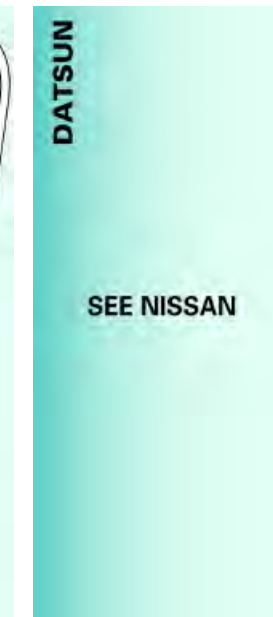
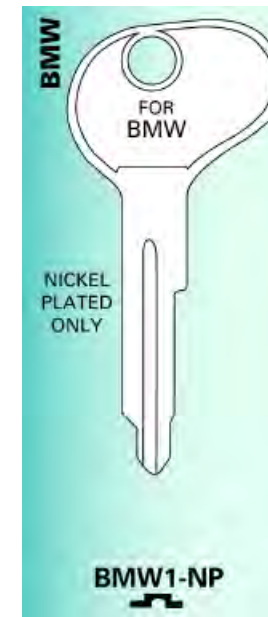
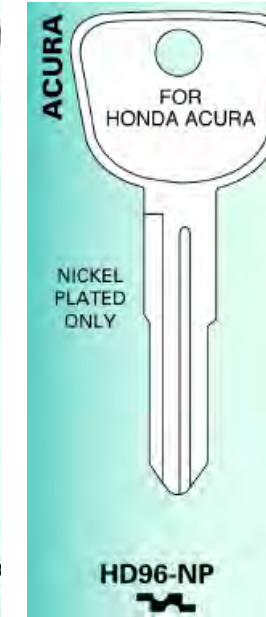
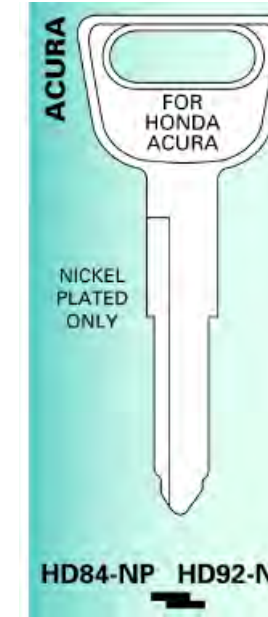
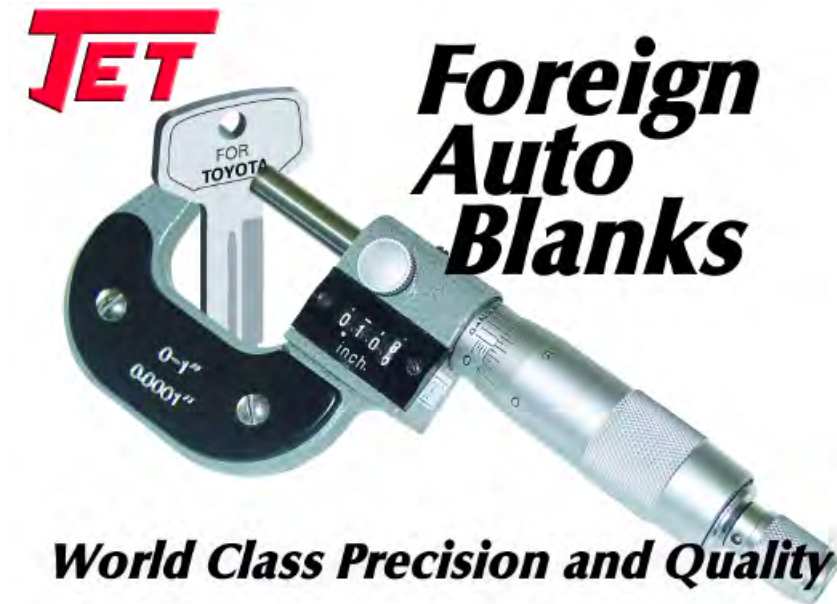
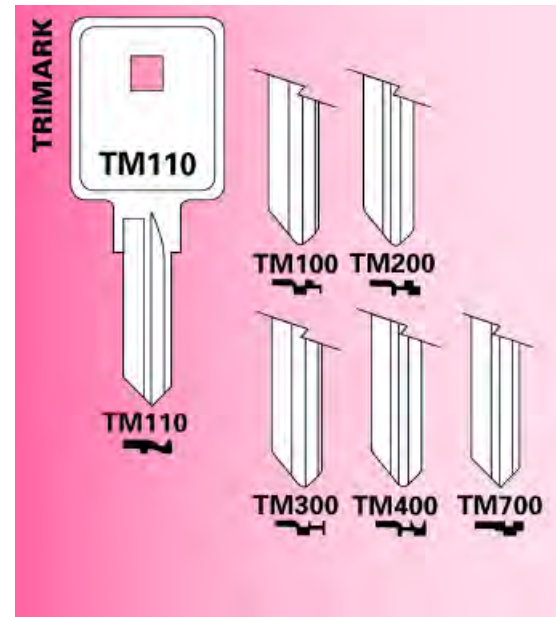
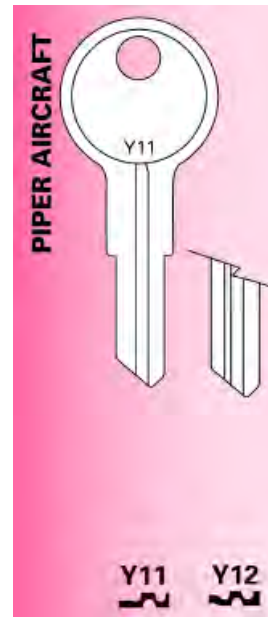
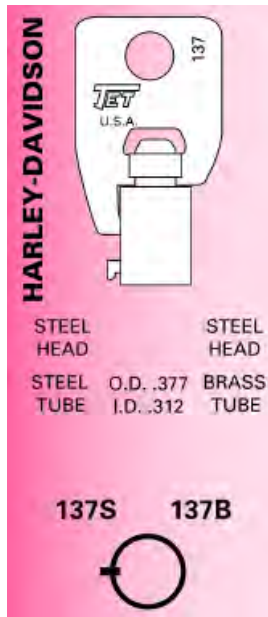
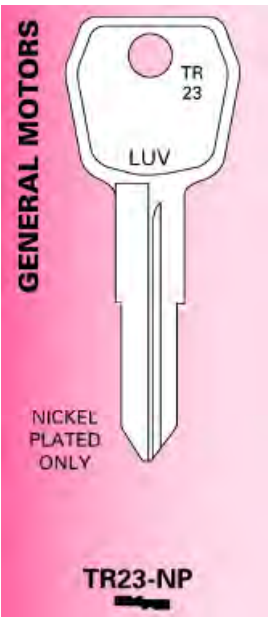
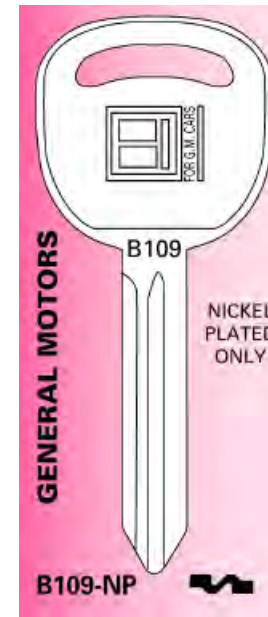
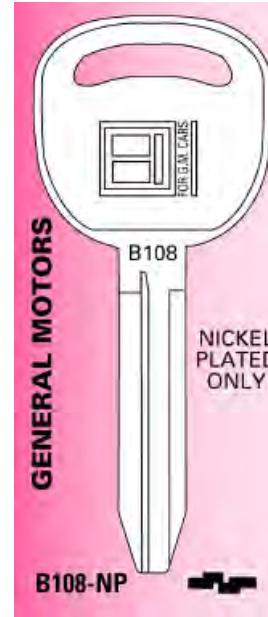

TET Foreign Auto Key Blanks

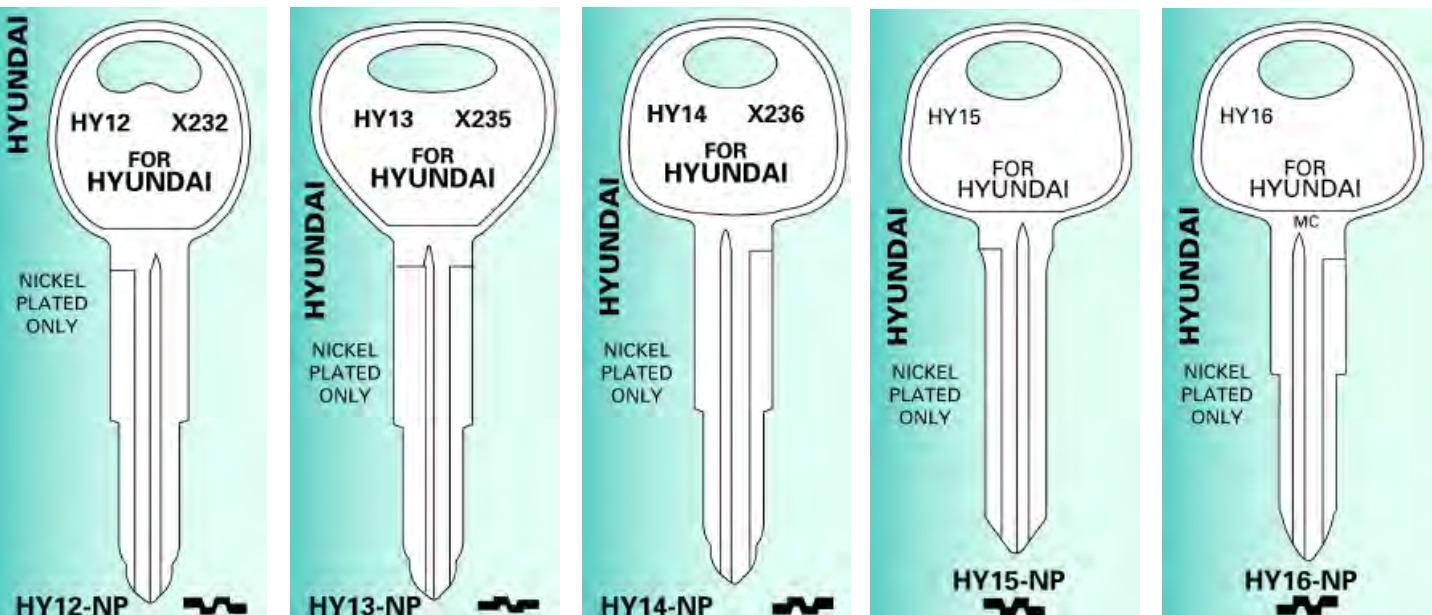
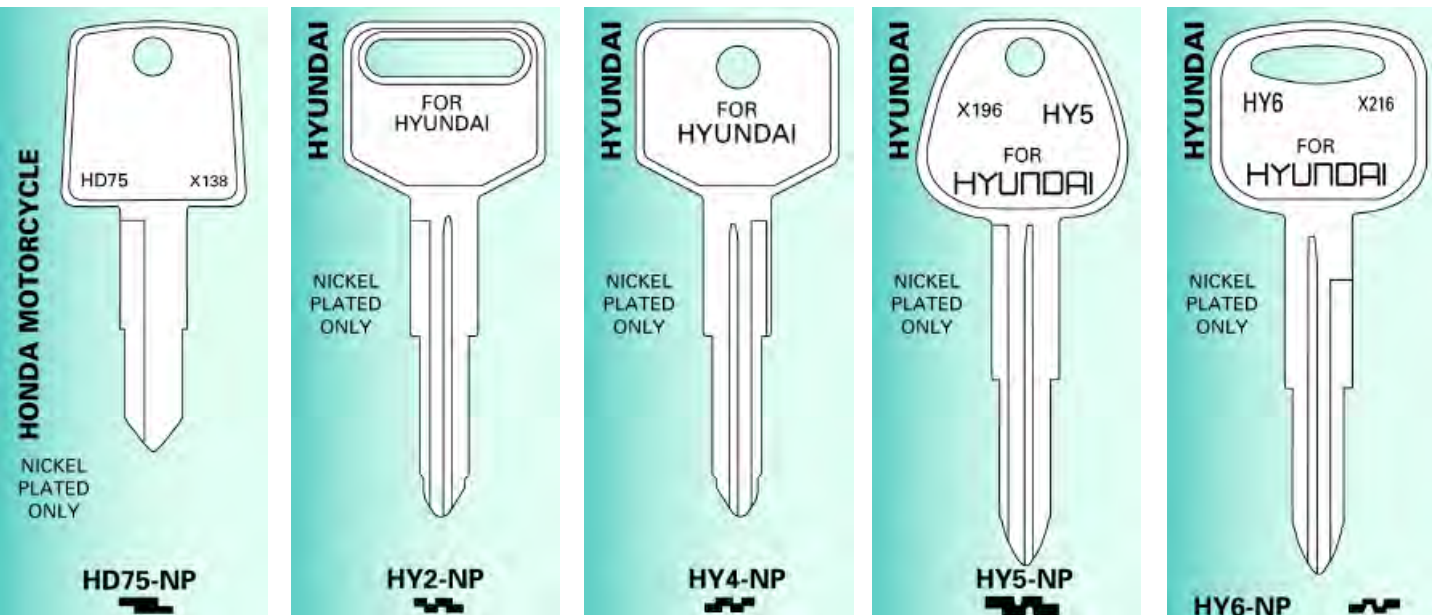
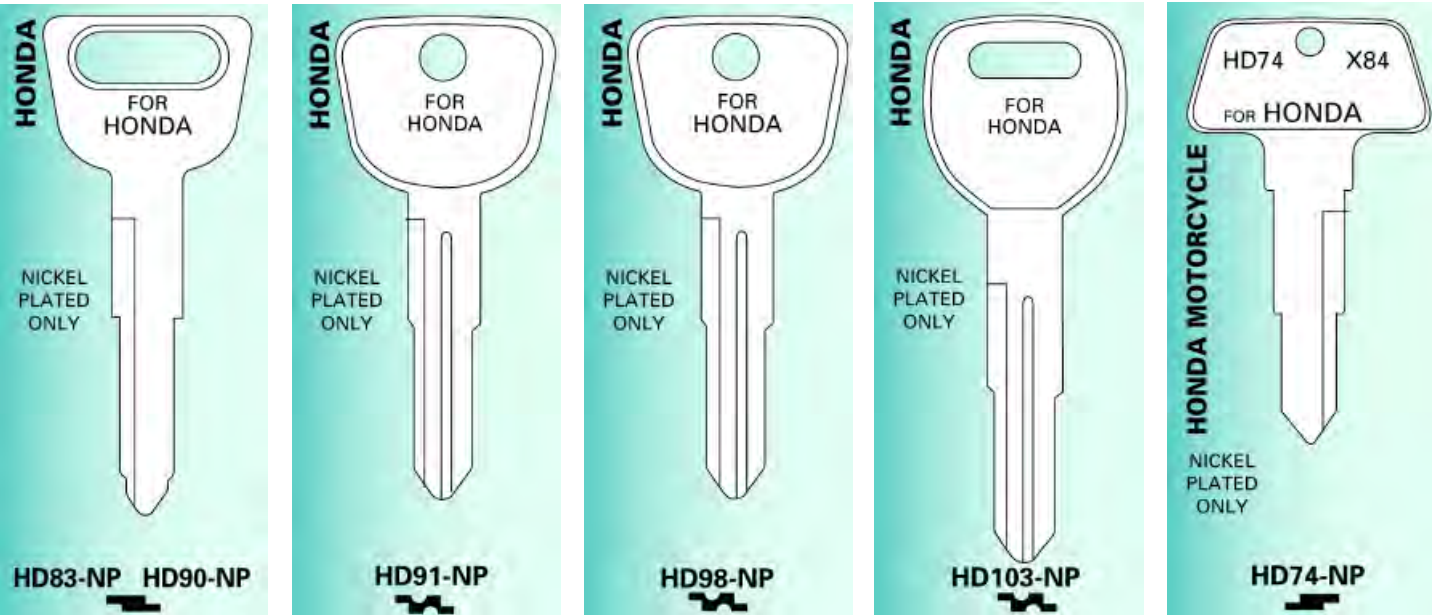

Foreign Auto Key Blanks TET

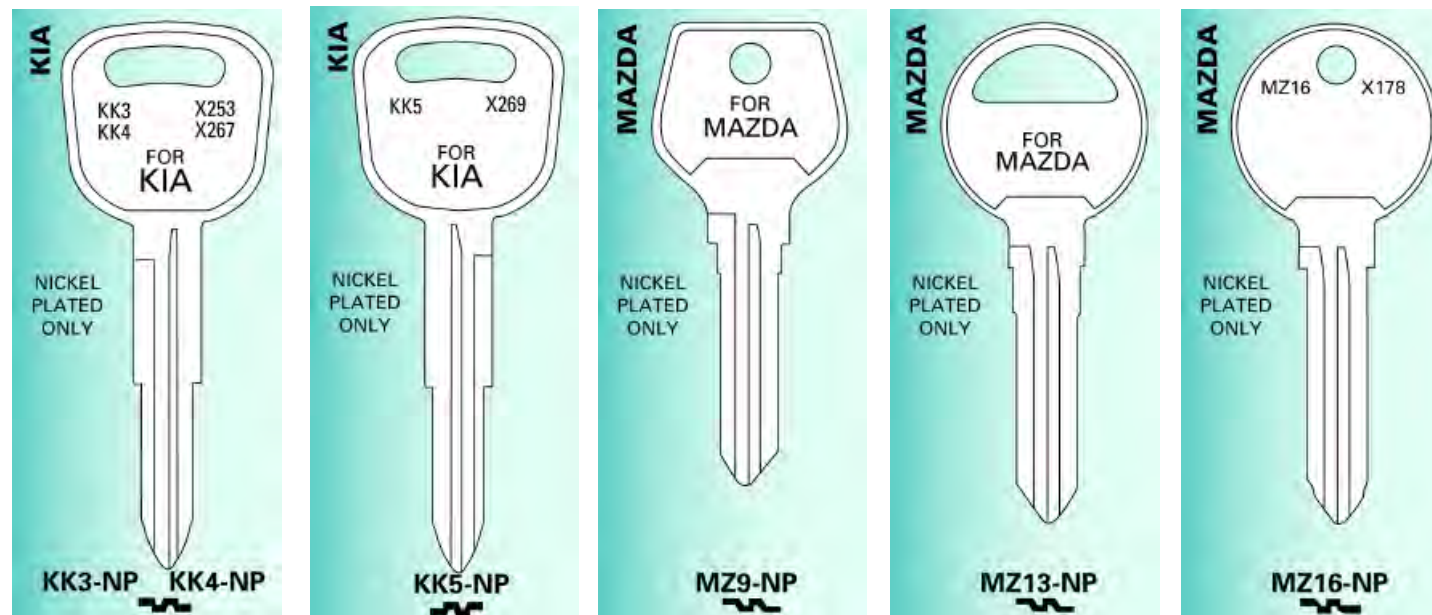
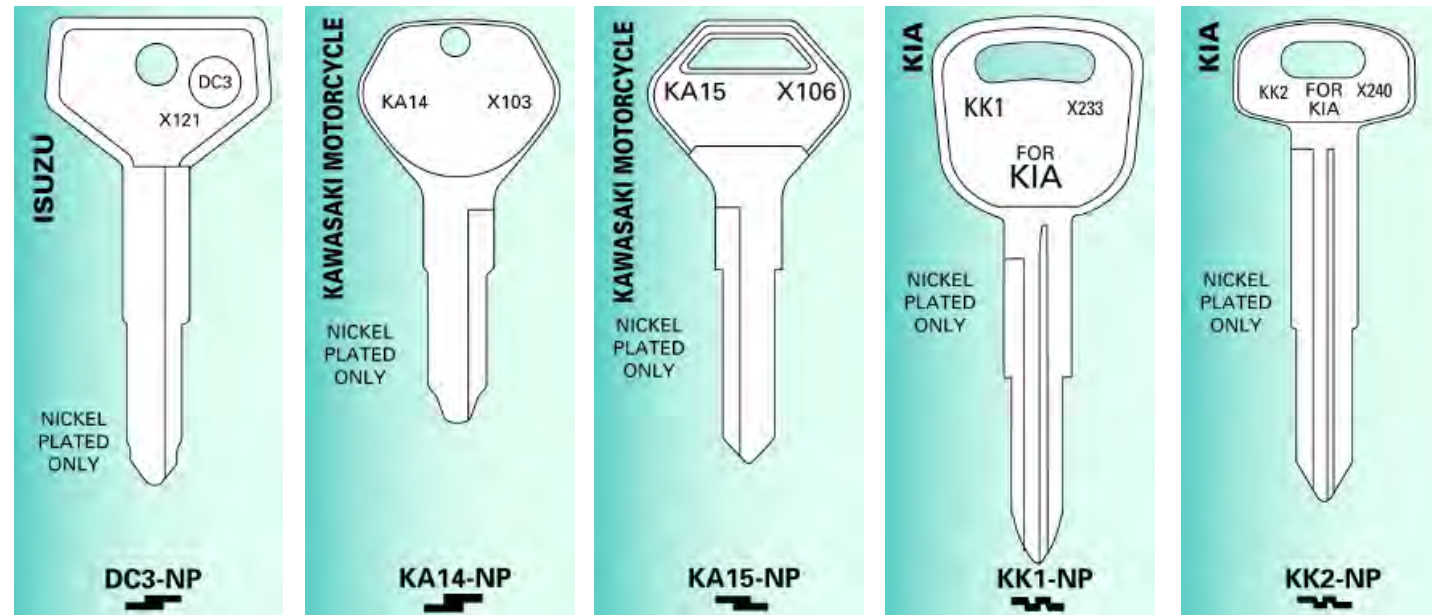
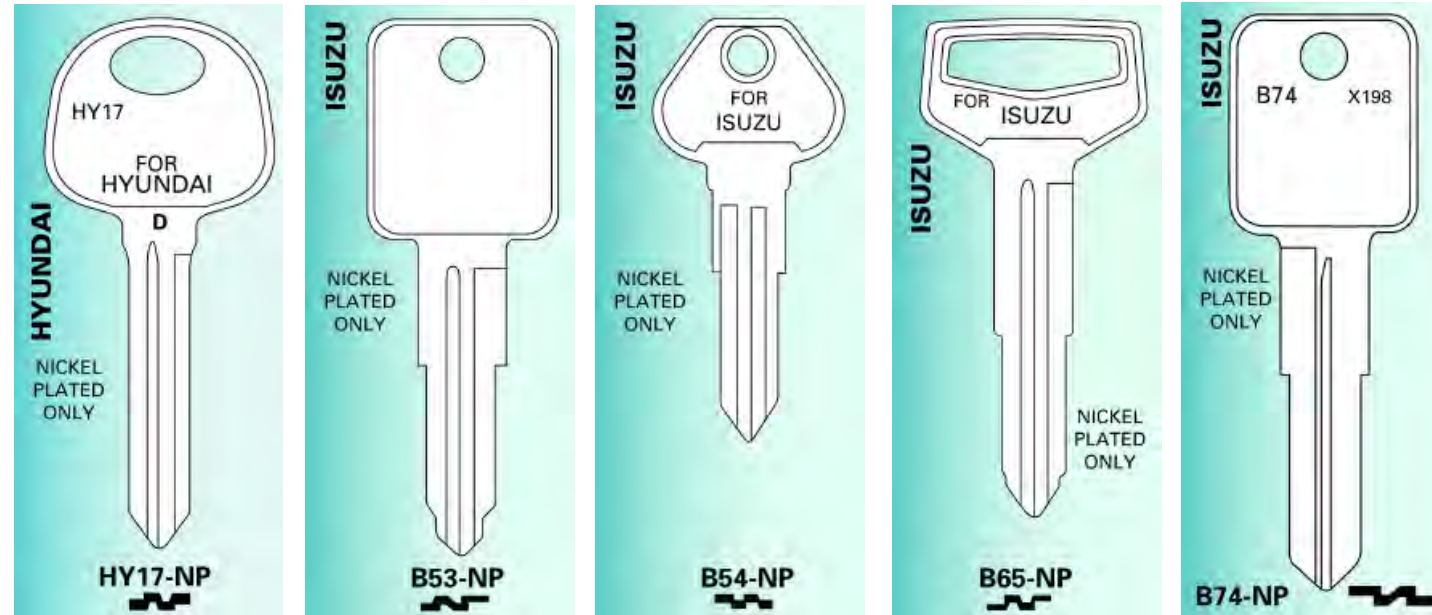

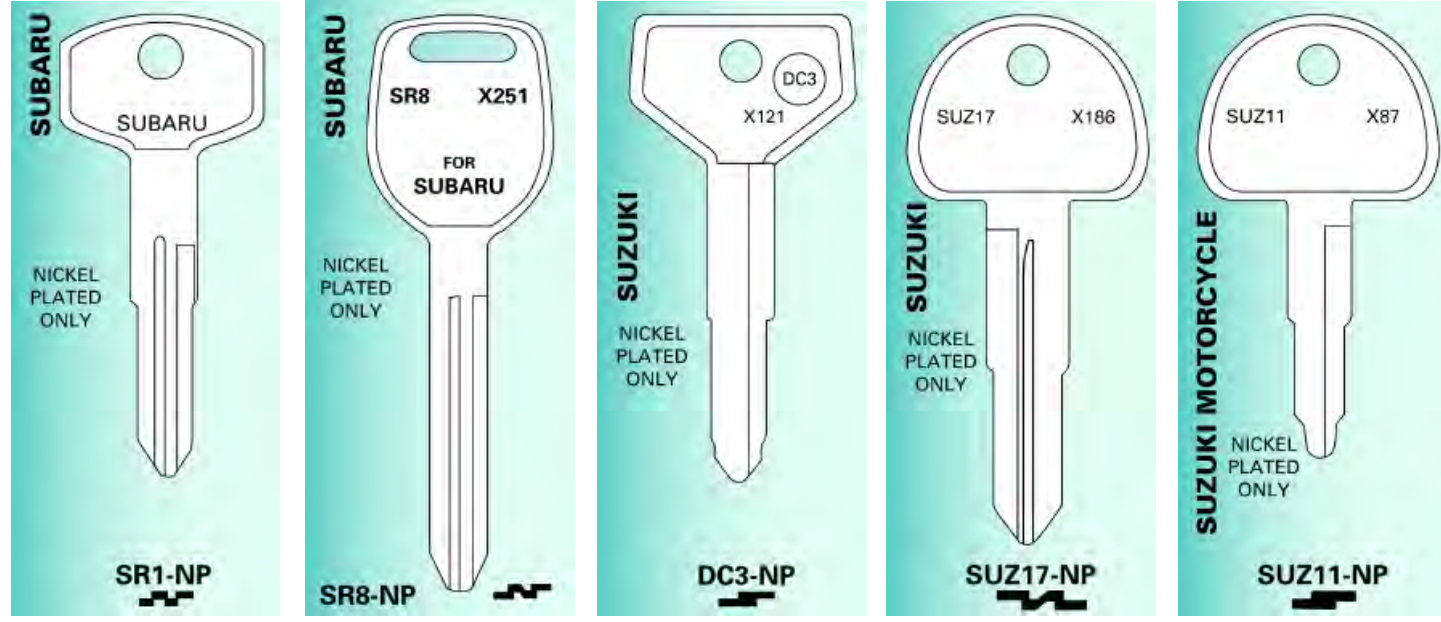
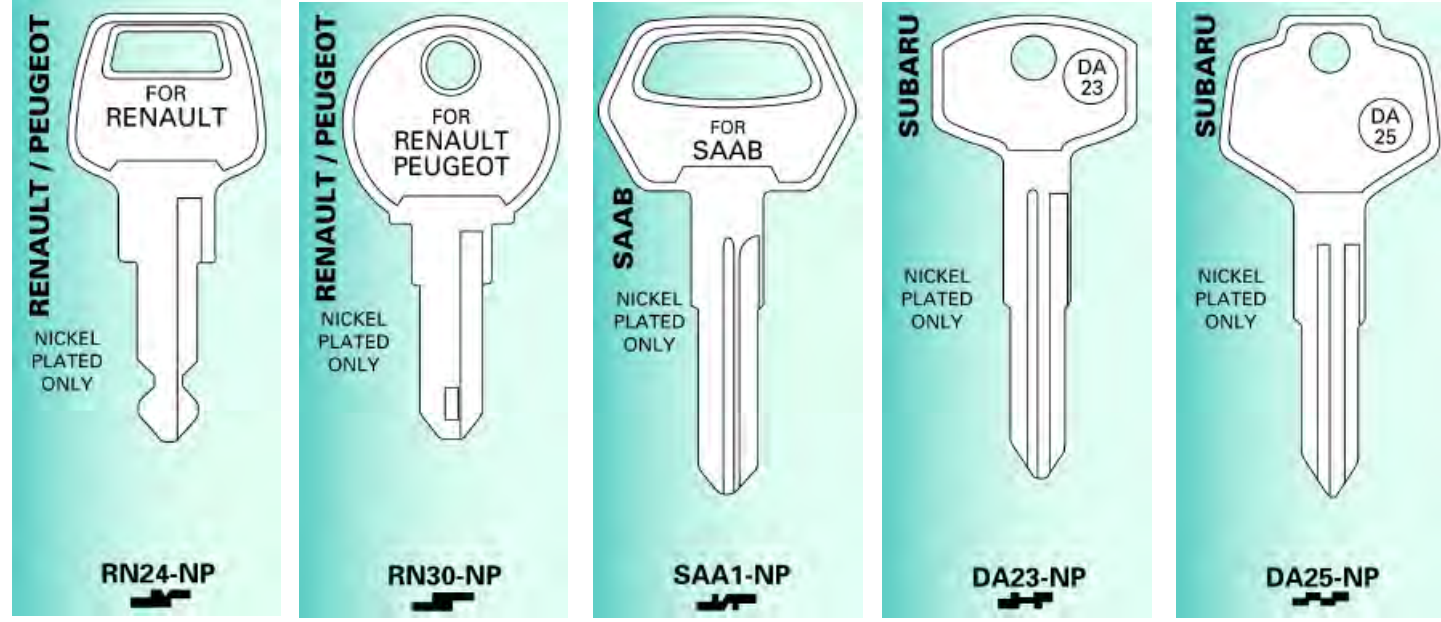
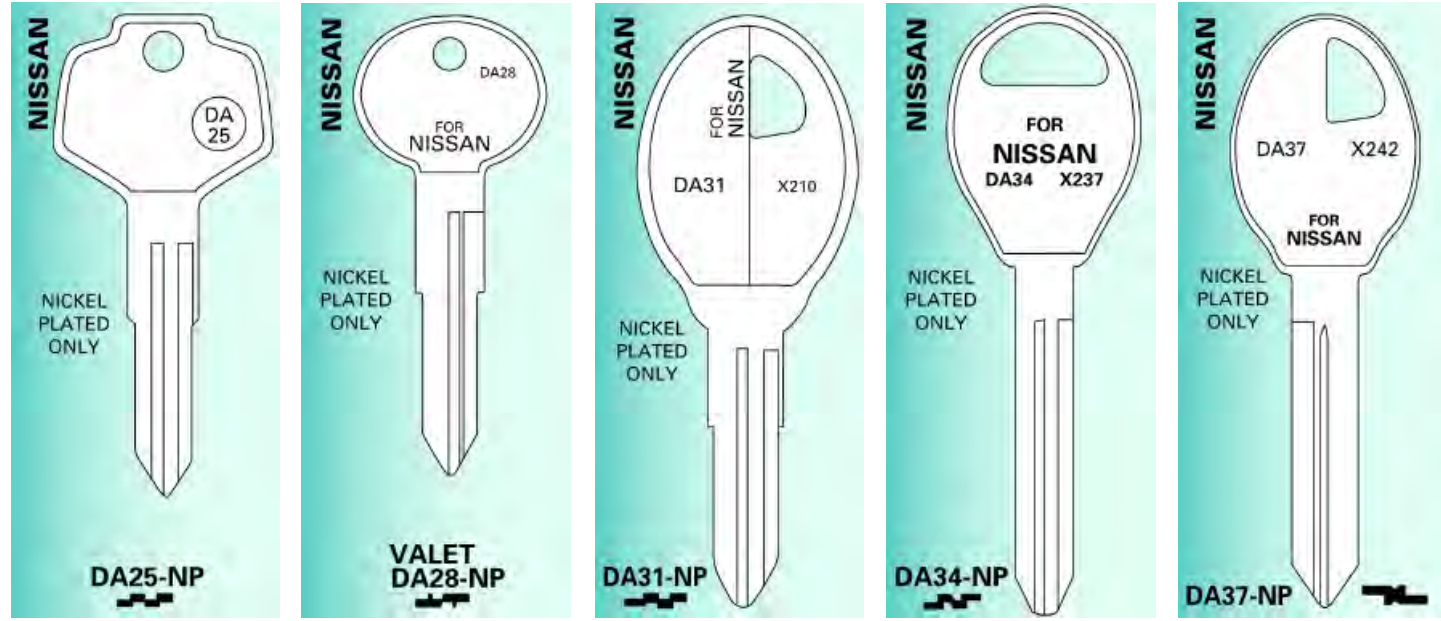
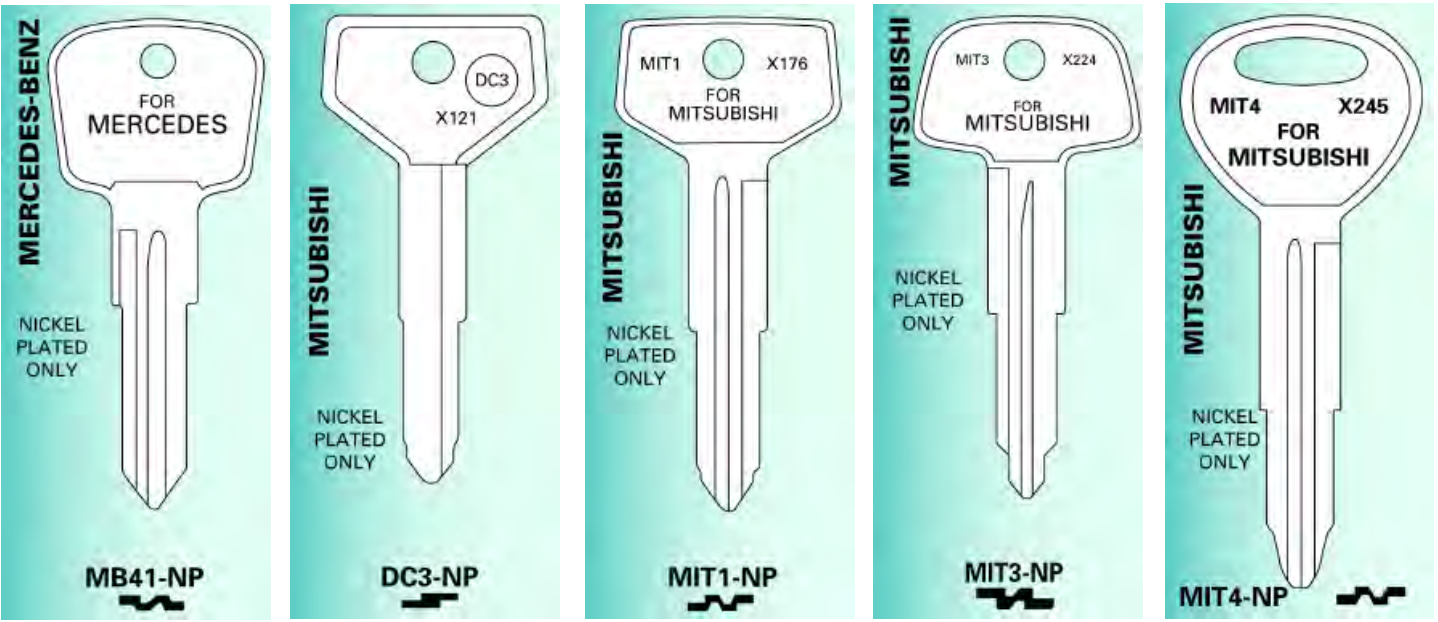
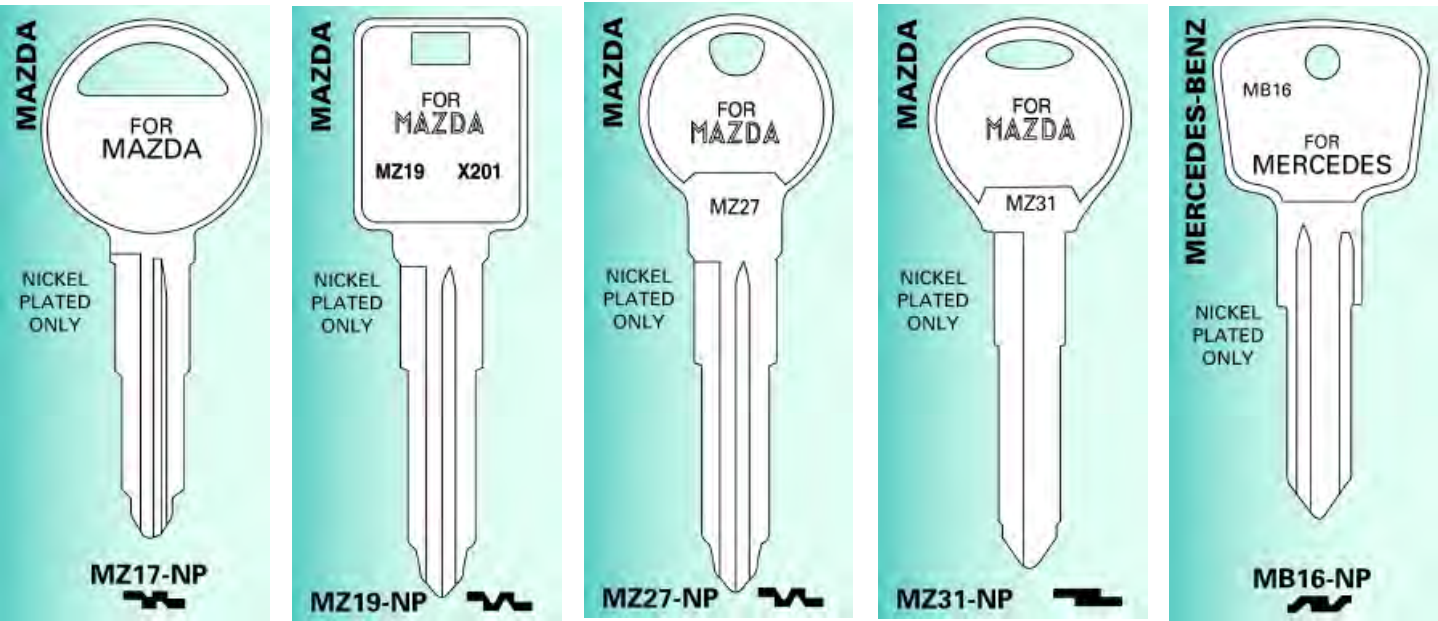

TET Foreign Auto Key Blanks

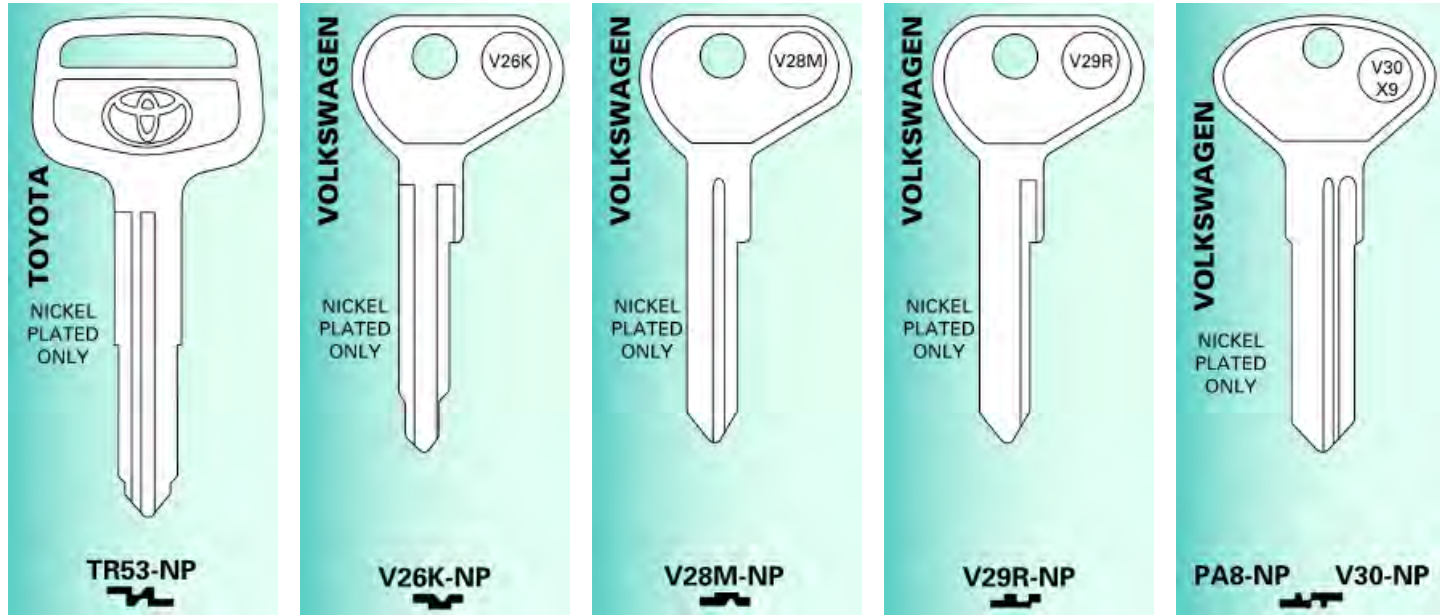
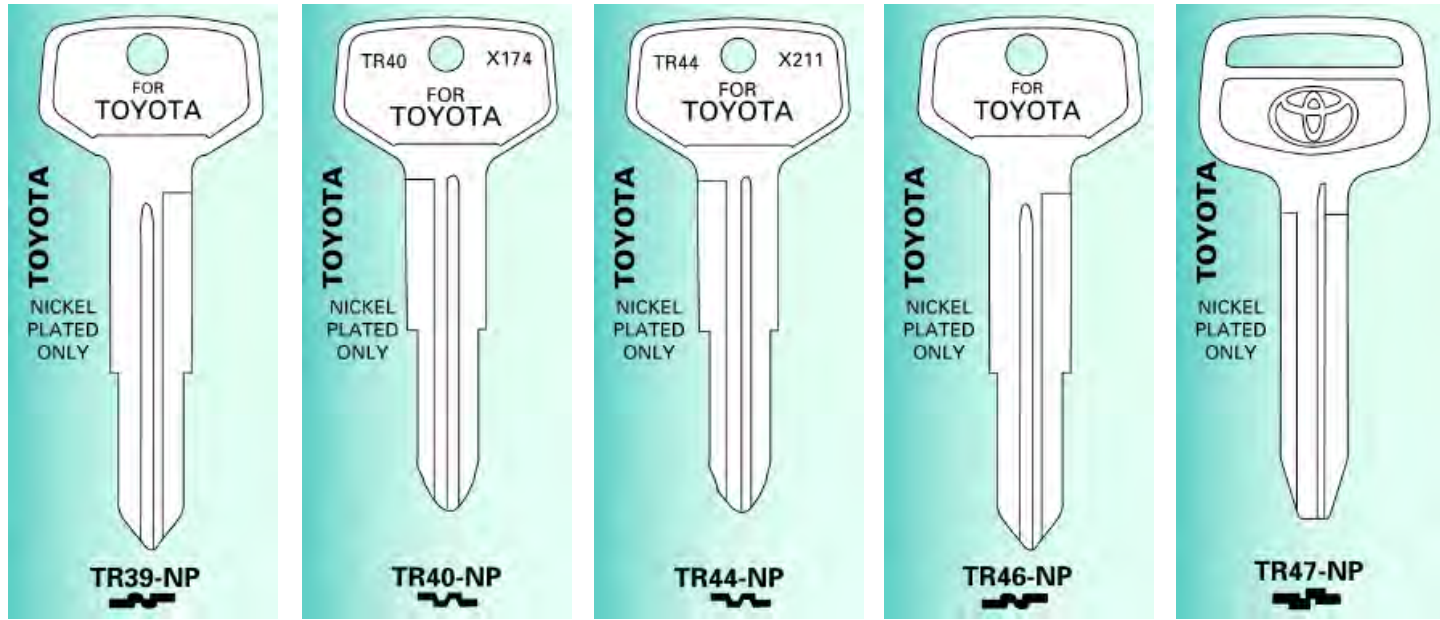
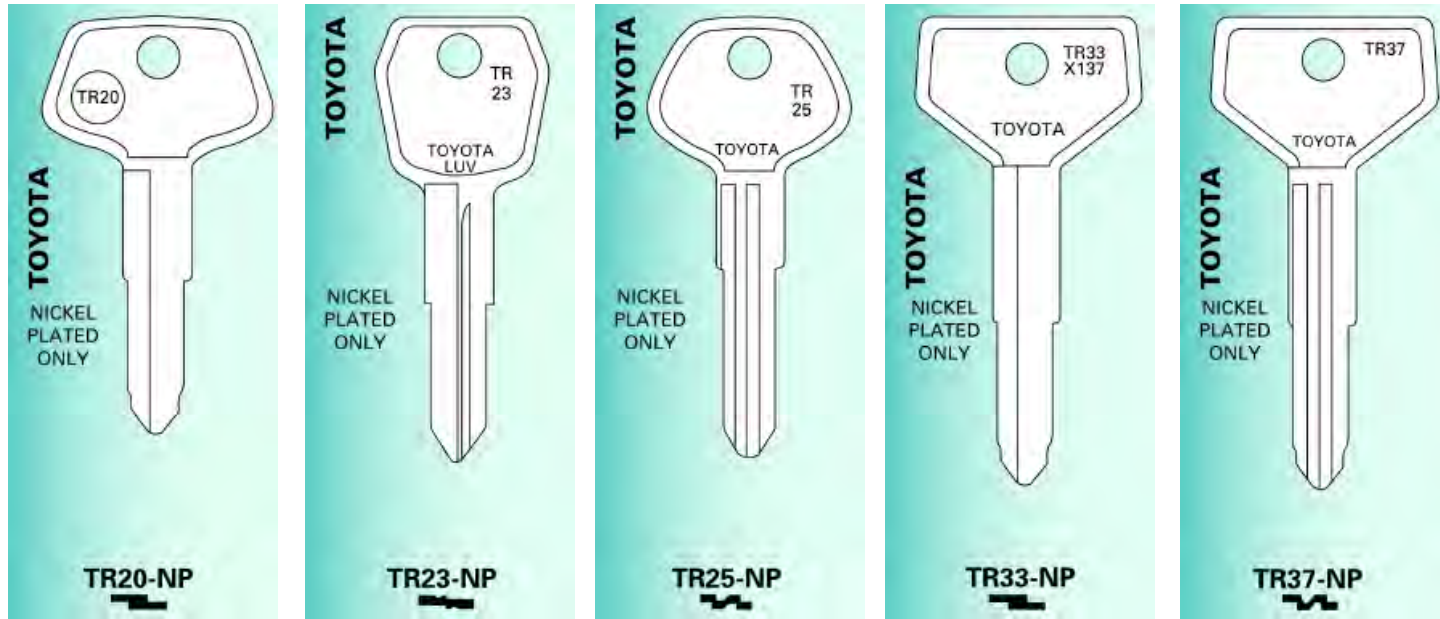

Foreign Auto Key Blanks TET

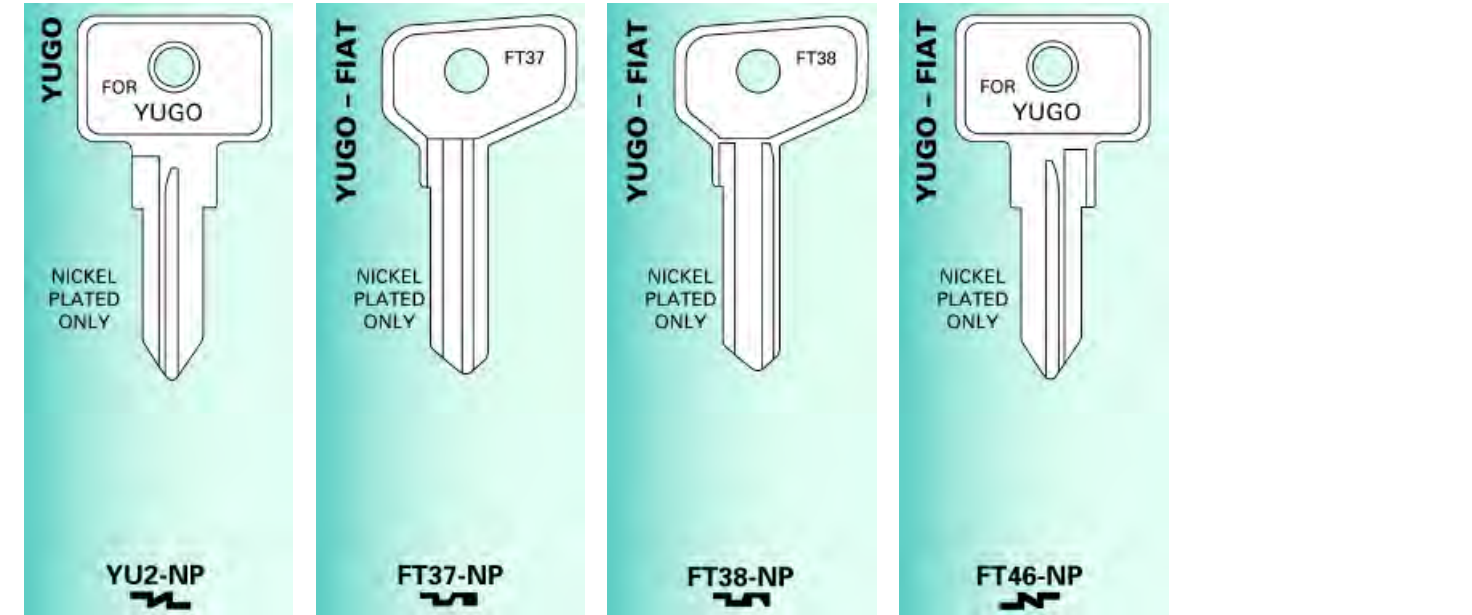
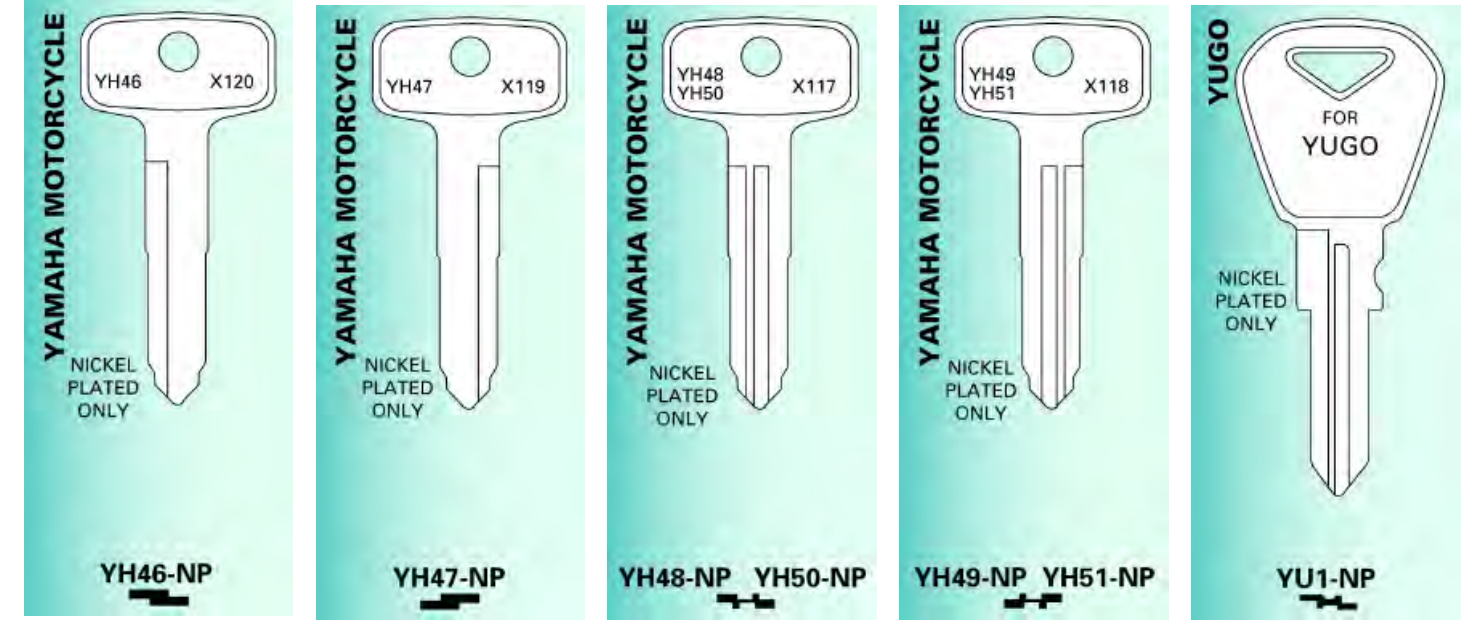
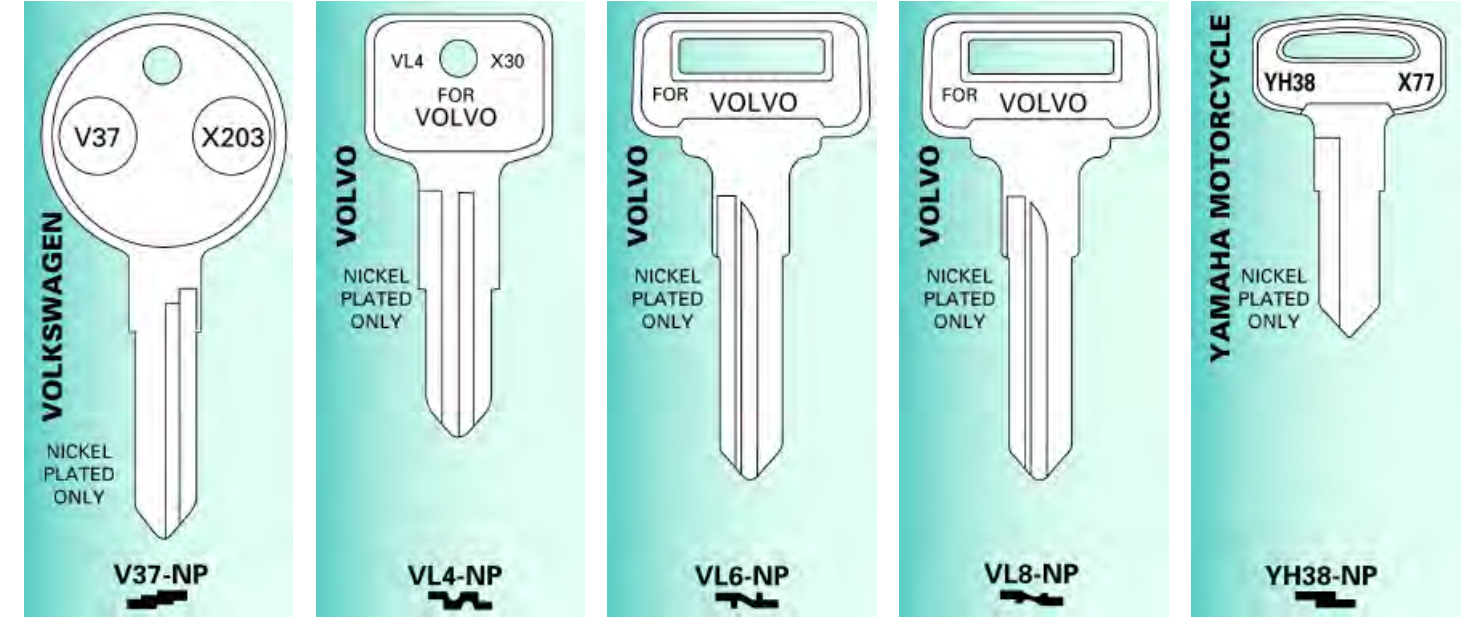

TET *Plastic Bow and VATS Auto Blanks*

World Class Precision and Quality

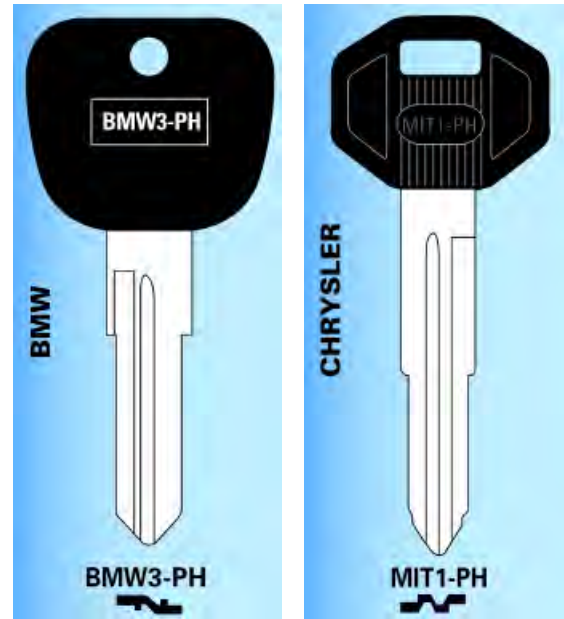

Plastic Bow Key Blanks **TET**

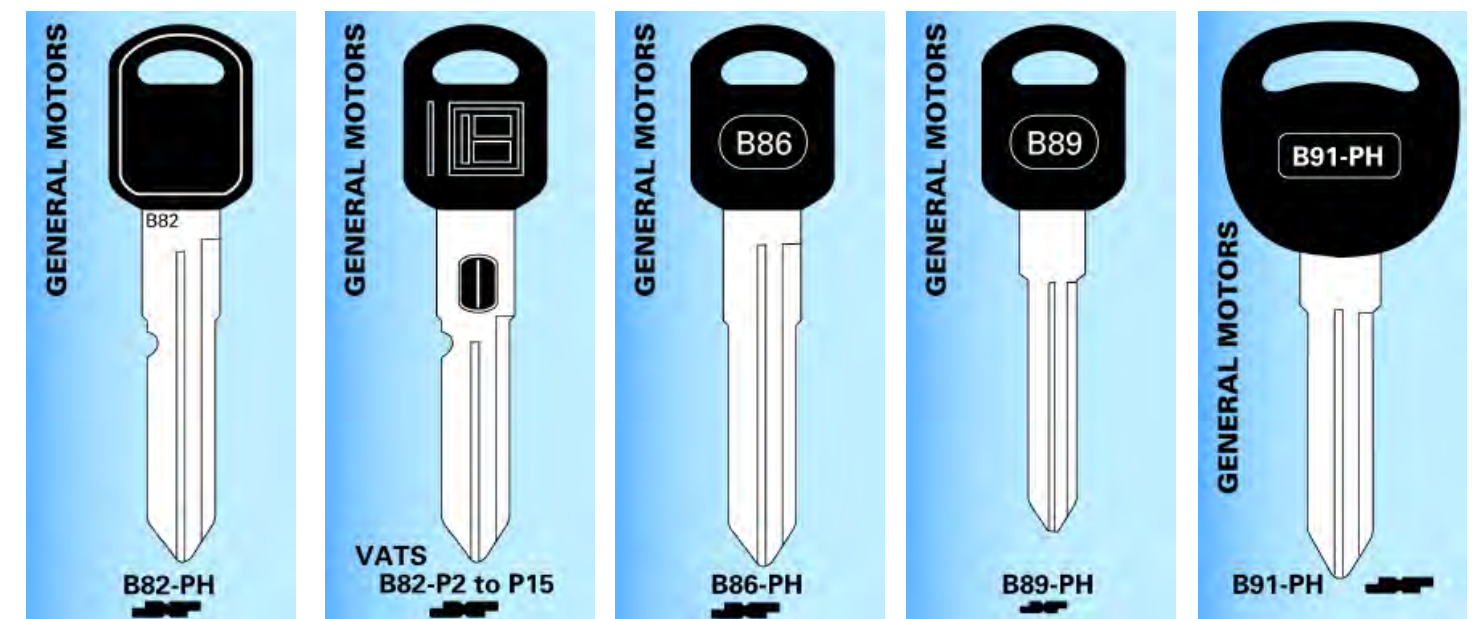
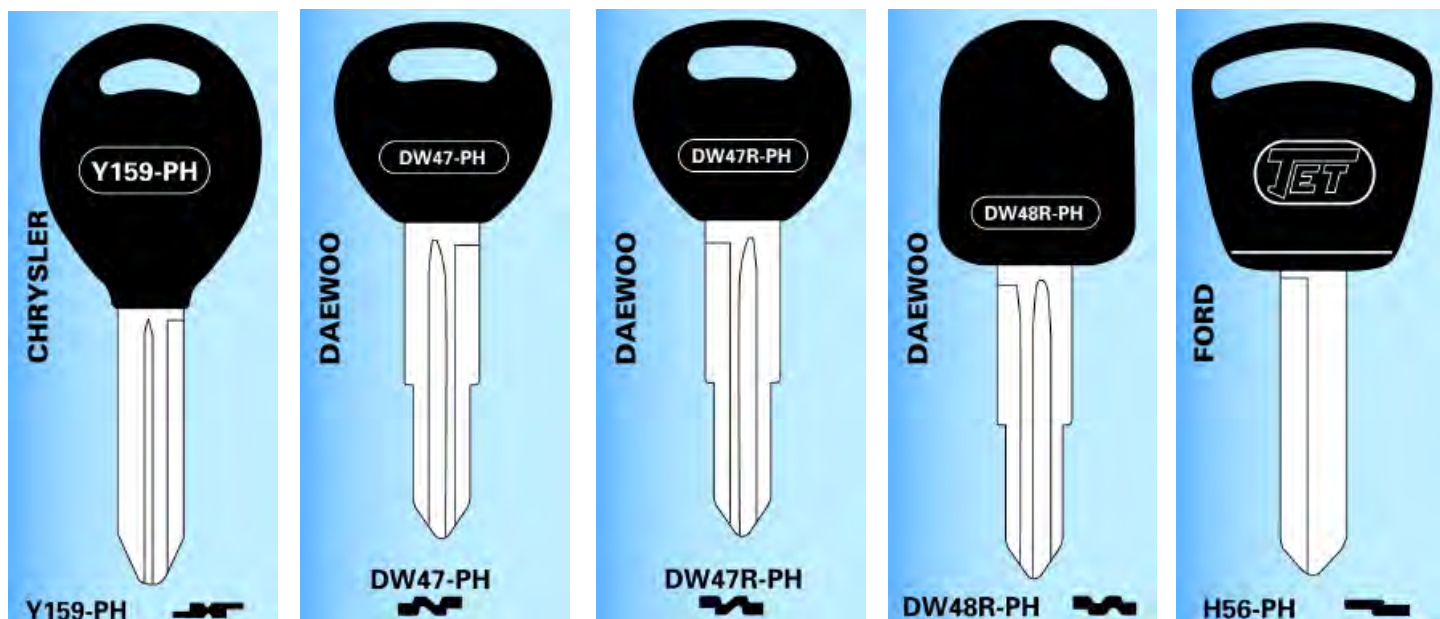
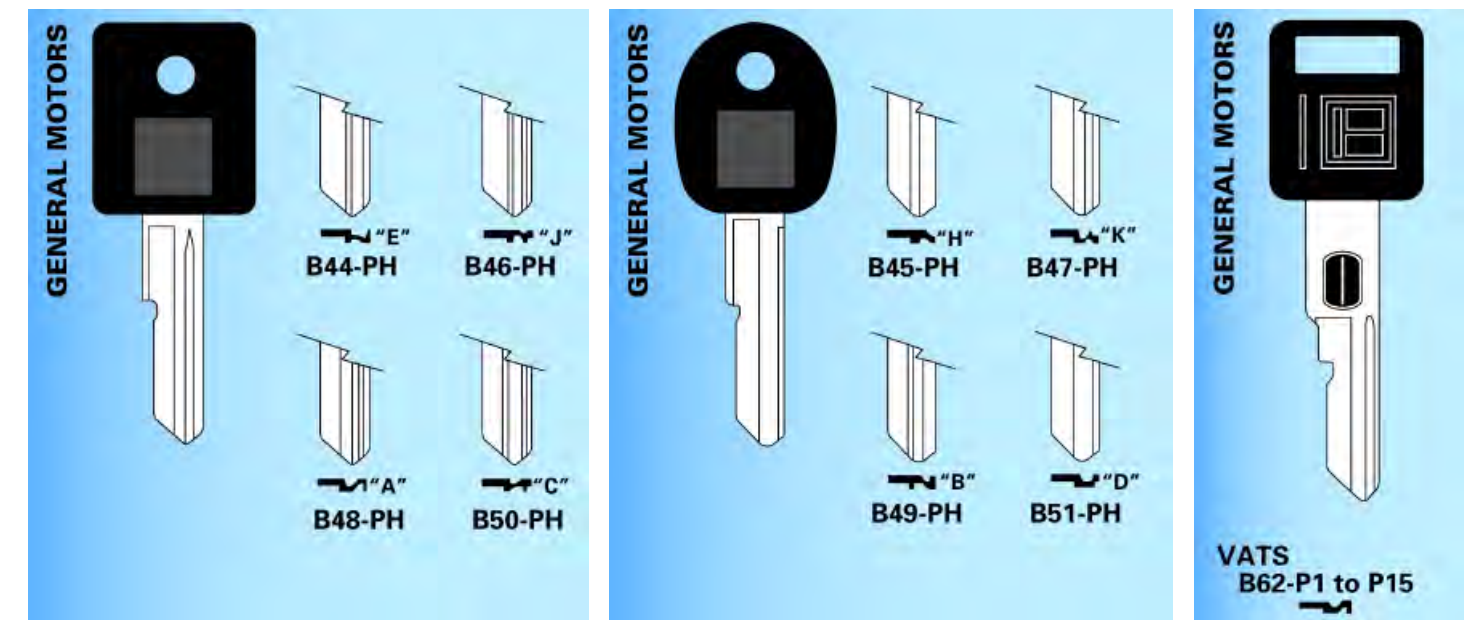
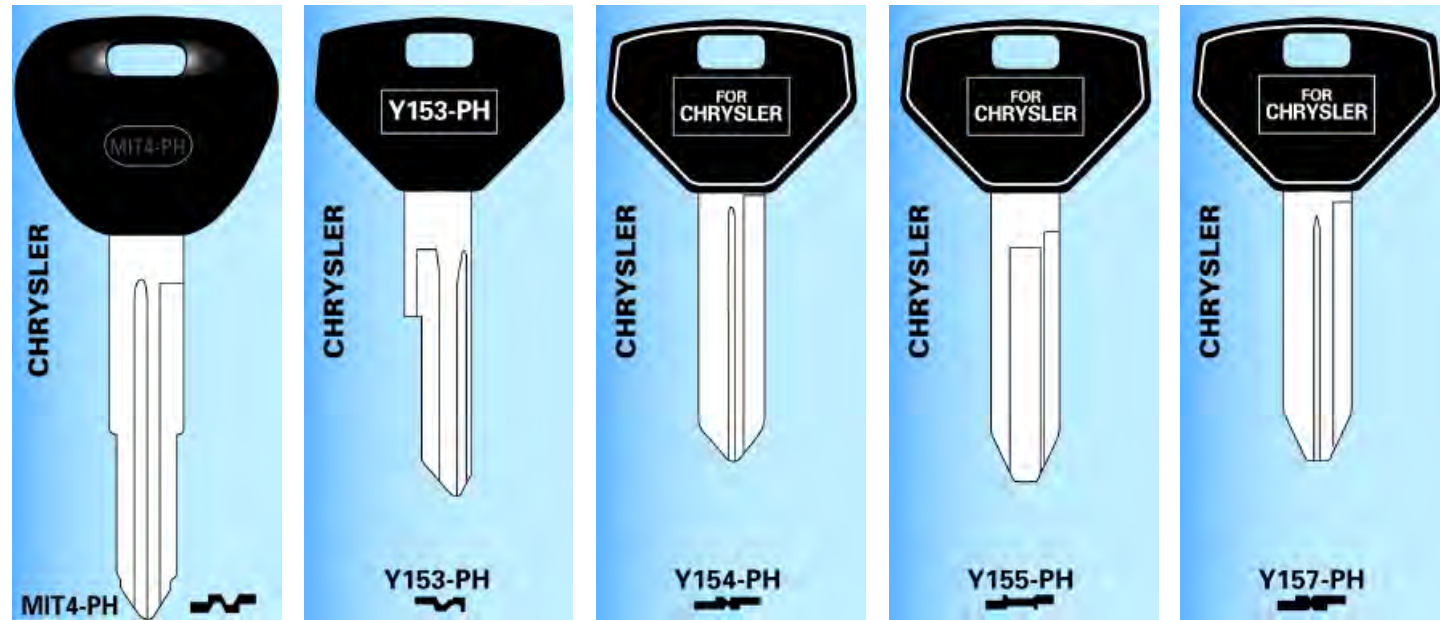
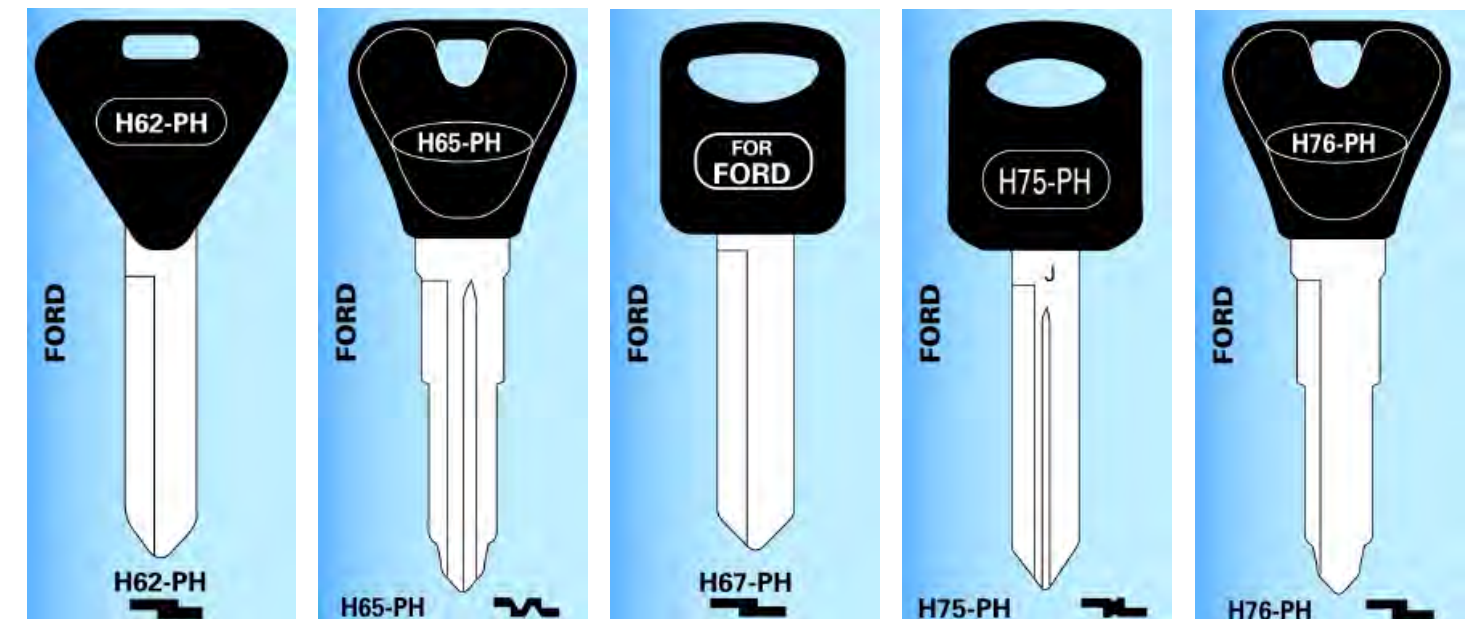

TET Plastic Bow Key Blanks



Plastic Bow Key Blanks TET



JET Plastic Bow Key Blanks

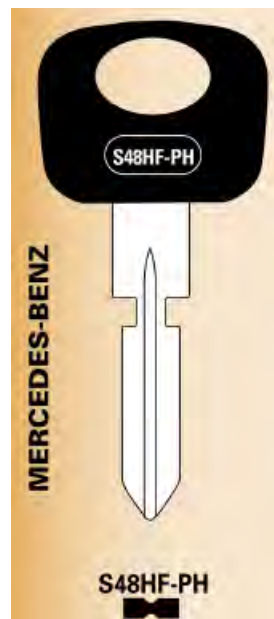
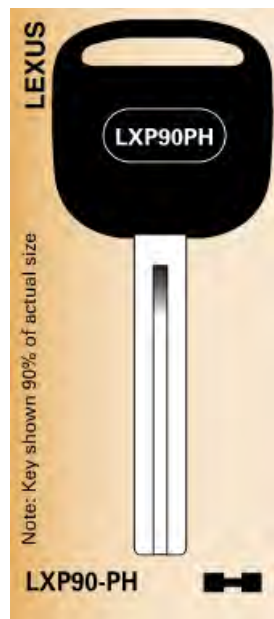
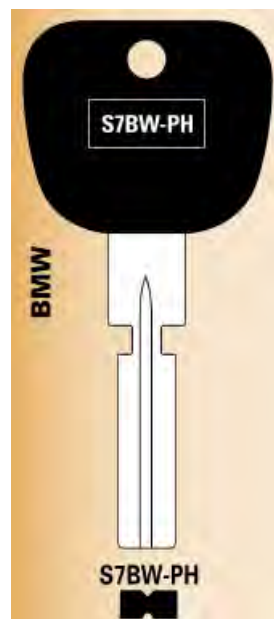
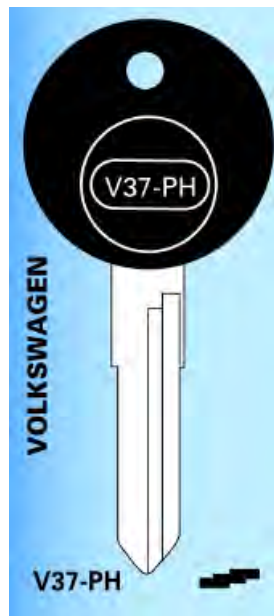
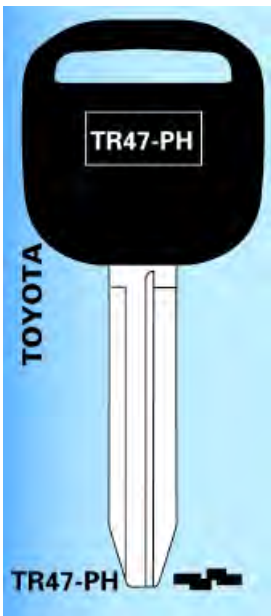

JET **Transponder Keys and Duplication Hardware**

World Class Precision and Quality

Images include: a key with a transponder chip, a key duplication machine, a key with a transponder chip, and a key with a transponder chip.

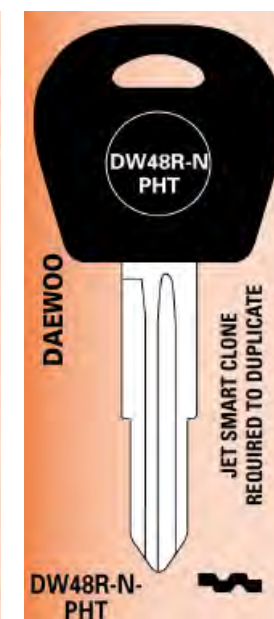
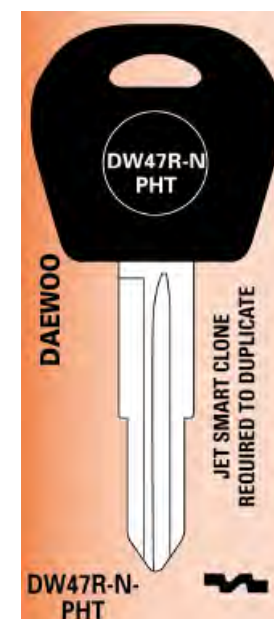
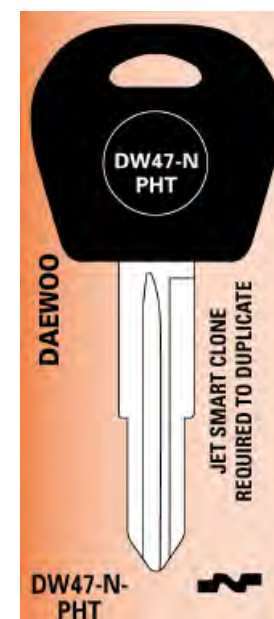
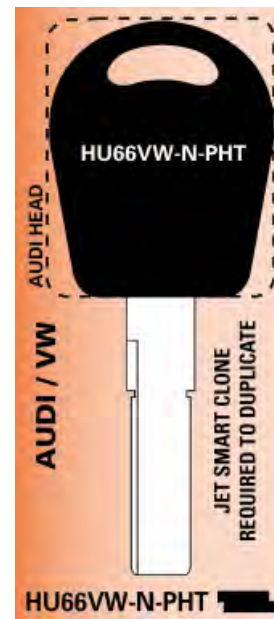

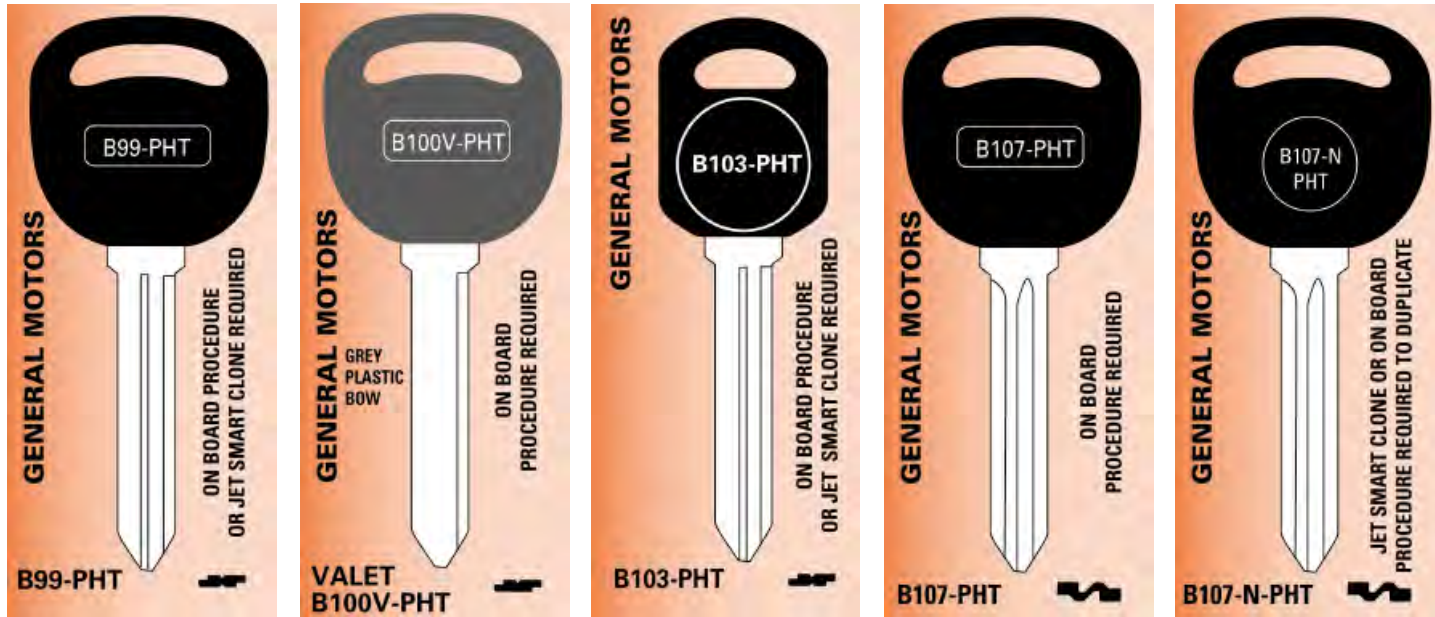
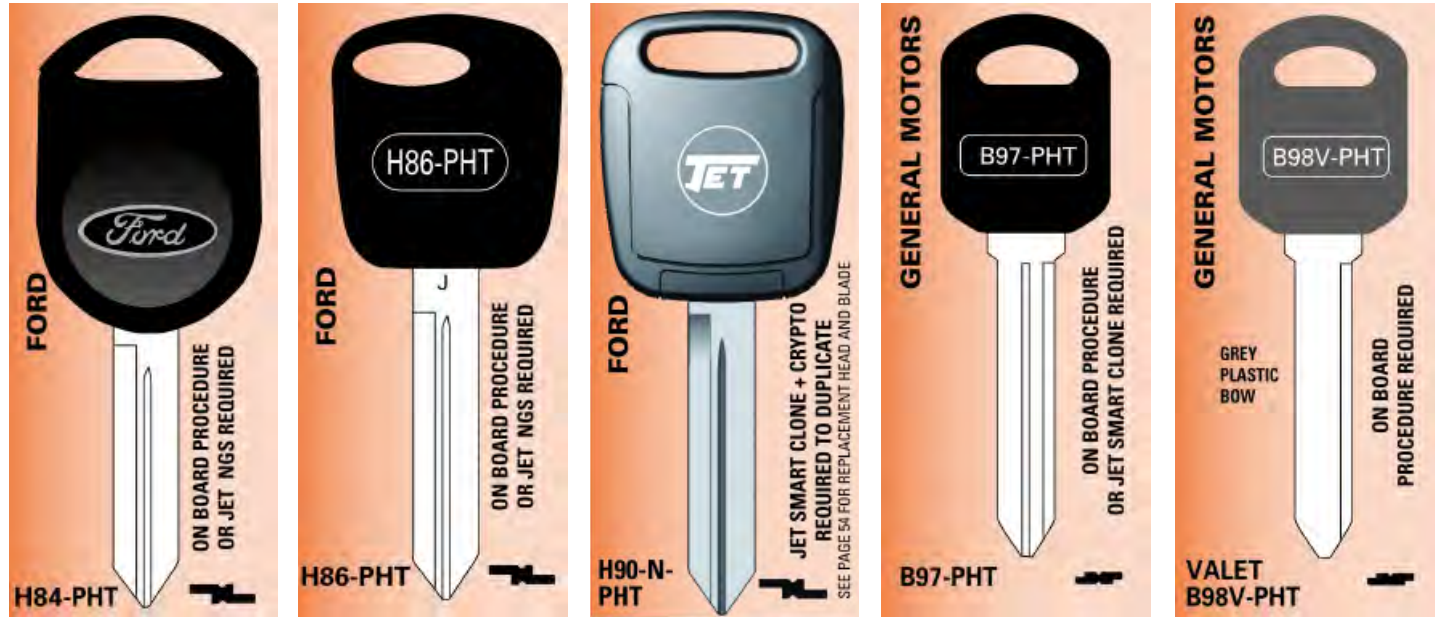
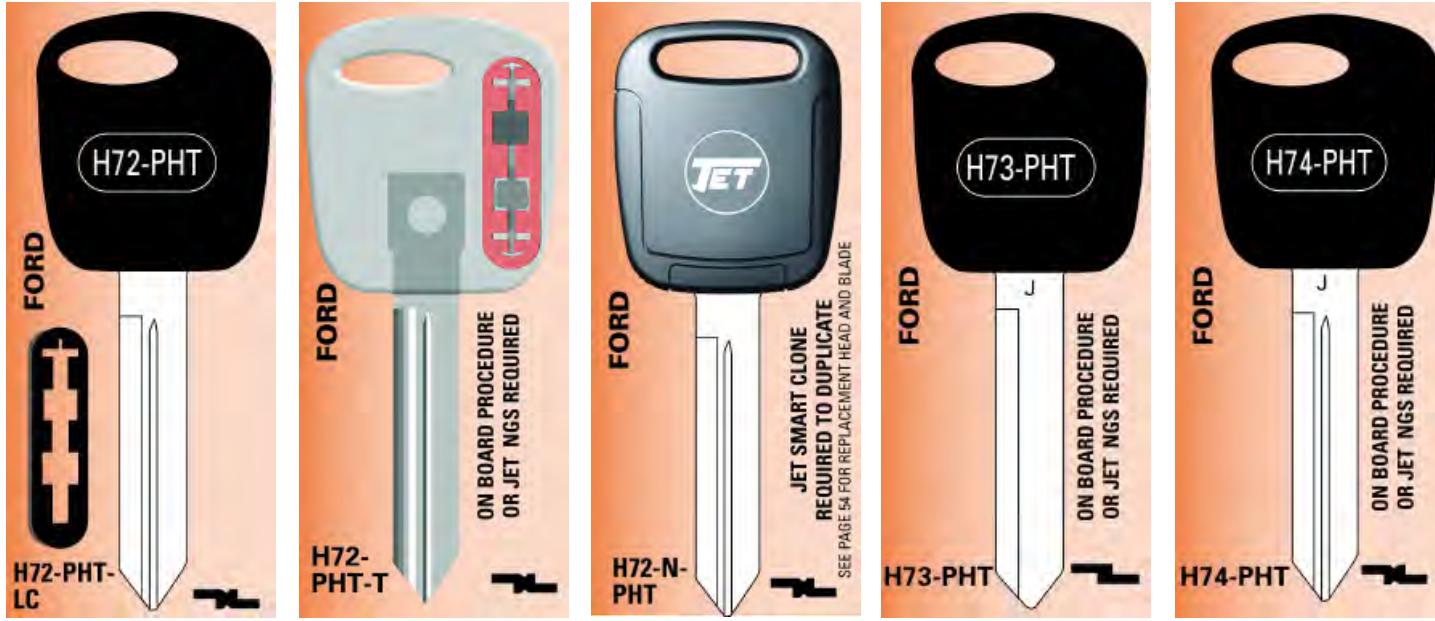

TET Transponder Key Blanks



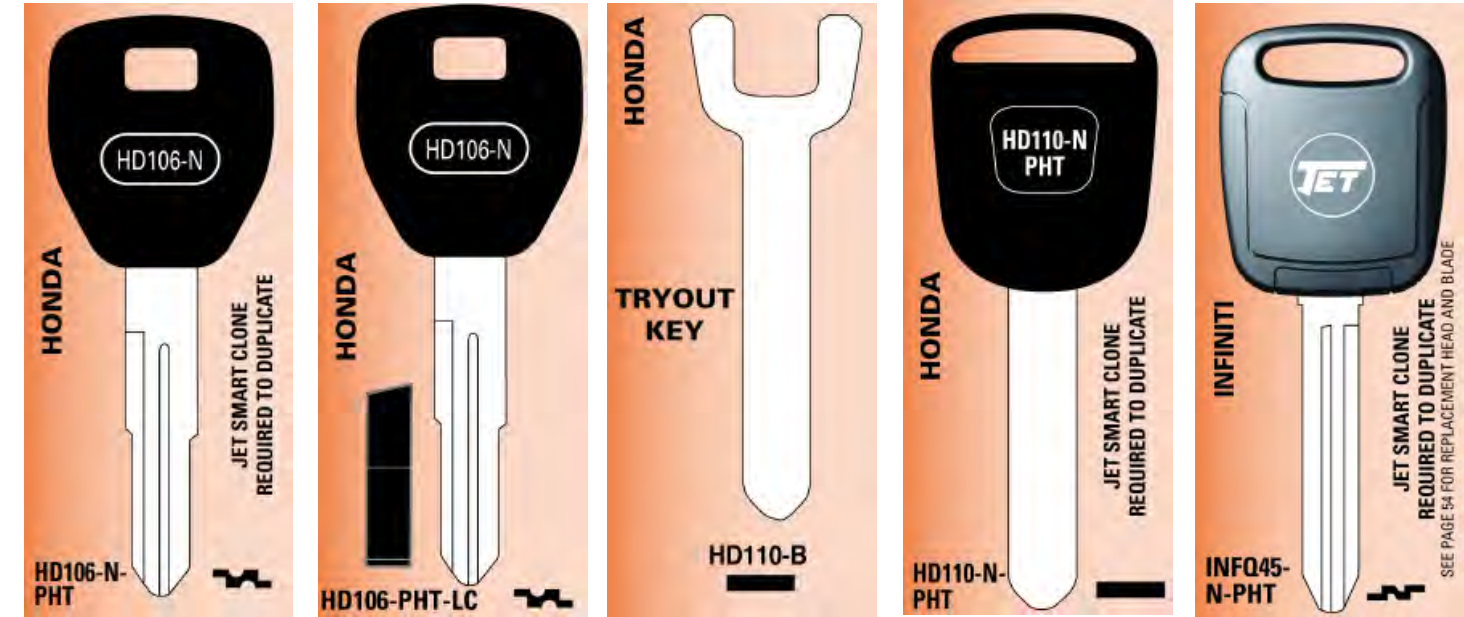
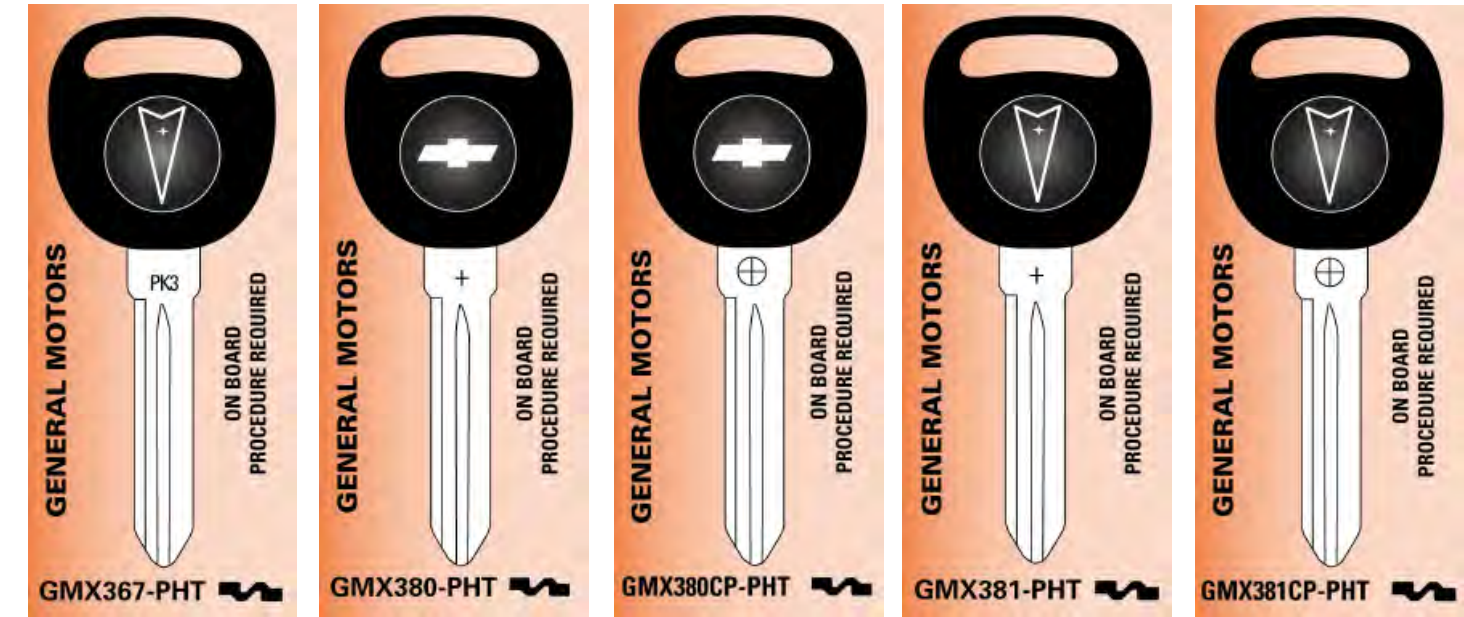
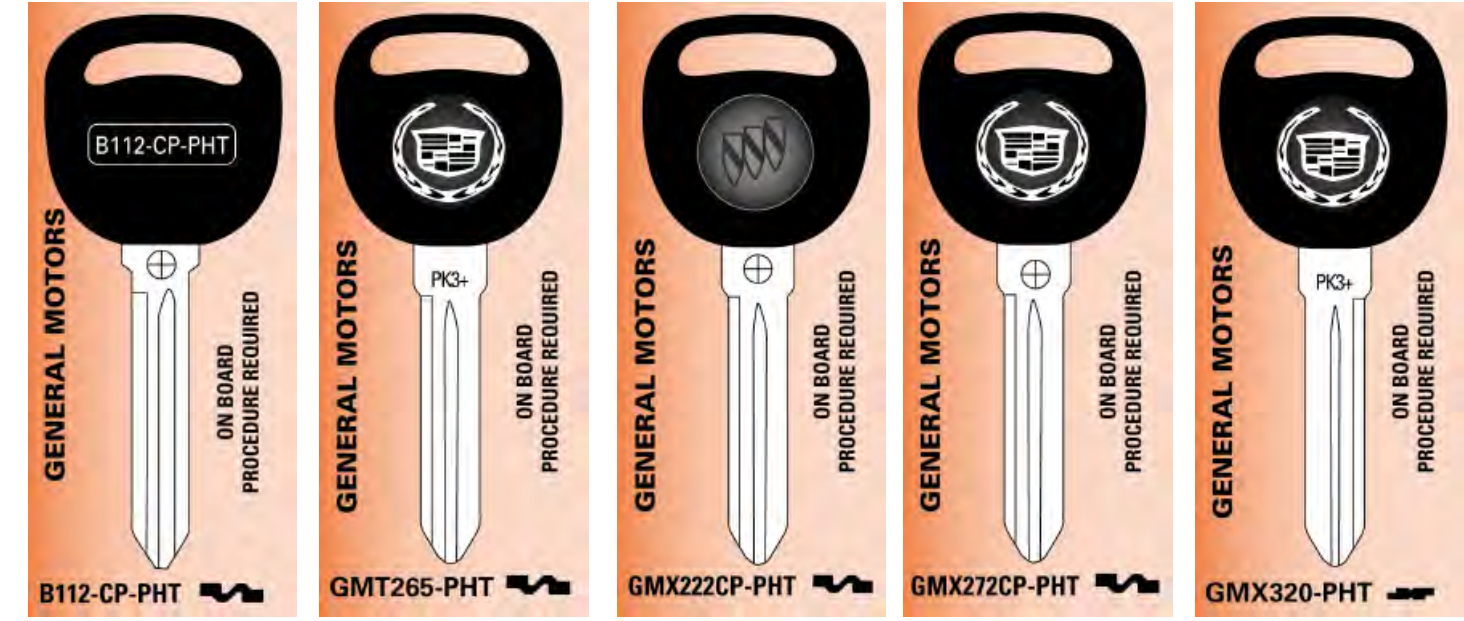



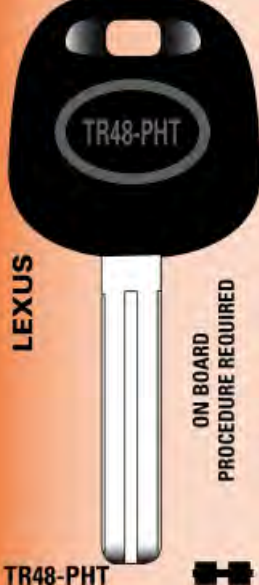
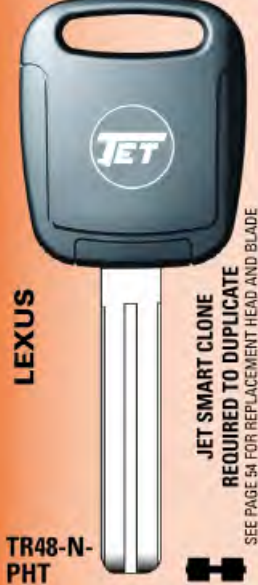

Transponder Key Blanks TET

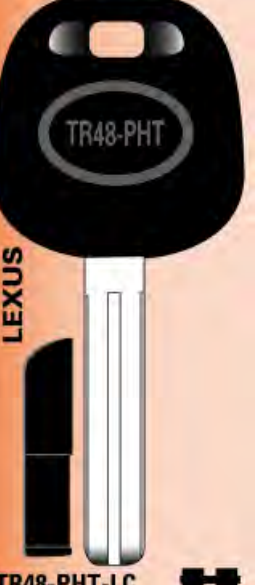
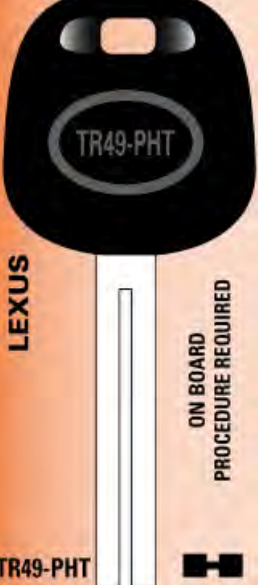
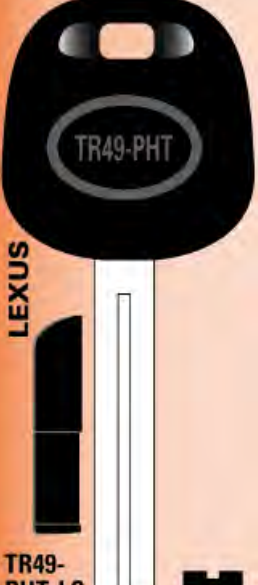



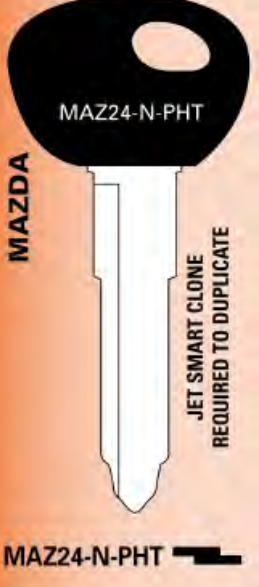

TET Transponder Key Blanks

<p>INFINITI</p>  <p>INFQ45-PHT</p>	<p>KIA</p>  <p>KK7-N-PHT</p> <p>JET SMART CLONE + CRYPTO REQUIRED TO DUPLICATE SEE PAGE 54 FOR REPLACEMENT HEAD AND BLADE</p>	<p>LEXUS</p>  <p>TRYOUT KEY</p> <p>TR48/49-B</p>	<p>LEXUS</p>  <p>TR48-PHT</p> <p>ON BOARD PROCEDURE REQUIRED</p>	<p>LEXUS</p>  <p>TR48-N-PHT</p> <p>JET SMART CLONE REQUIRED TO DUPLICATE SEE PAGE 54 FOR REPLACEMENT HEAD AND BLADE</p>
---	---	--	---	---

<p>LEXUS</p>  <p>TR48-PHT</p>	<p>LEXUS</p>  <p>TR49-PHT</p> <p>ON BOARD PROCEDURE REQUIRED</p>	<p>LEXUS</p>  <p>TR49-PHT</p>	<p>LEXUS</p>  <p>TR49-N-PHT</p> <p>JET SMART CLONE REQUIRED TO DUPLICATE SEE PAGE 54 FOR REPLACEMENT HEAD AND BLADE</p>	<p>LEXUS</p>  <p>TR60-N-PHT</p> <p>JET SMART CLONE + CRYPTO REQUIRED TO DUPLICATE SEE PAGE 54 FOR REPLACEMENT HEAD AND BLADE</p>
---	---	--	---	---

<p>MAZDA</p>  <p>MAZ24-N-PHT</p> <p>JET SMART CLONE REQUIRED TO DUPLICATE</p> <p>MAZ24-N-PHT</p>	<p>MAZDA</p>  <p>MZ34-N-PHT</p> <p>JET SMART CLONE + CRYPTO REQUIRED TO DUPLICATE SEE PAGE 54 FOR REPLACEMENT HEAD AND BLADE</p>	<p>MITSUBISHI</p>  <p>MIT10-PHT</p>	<p>MITSUBISHI</p>  <p>MIT11-PHT</p>	<p>MITSUBISHI</p>  <p>MIT12-N-PHT</p> <p>JET SMART CLONE + CRYPTO REQUIRED TO DUPLICATE SEE PAGE 54 FOR REPLACEMENT HEAD AND BLADE</p>
---	--	---	--	--

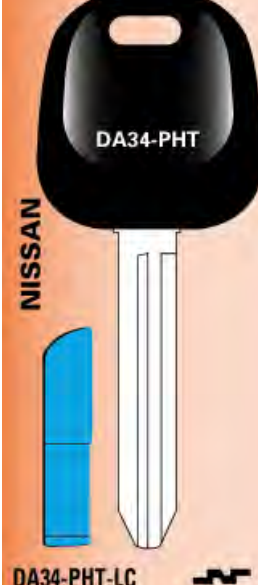
Transponder Key Blanks TET

<p>MITSUBISHI</p>  <p>MIT13-N-PHT</p> <p>JET SMART CLONE + CRYPTO REQUIRED TO DUPLICATE SEE PAGE 54 FOR REPLACEMENT HEAD AND BLADE</p>	<p>NISSAN</p>  <p>DA31-N-PHT</p> <p>JET SMART CLONE REQUIRED TO DUPLICATE</p>	<p>NISSAN</p>  <p>DA34-PHT</p>	<p>NISSAN</p>  <p>DA34-PHT-LC</p>	<p>NISSAN</p>  <p>DA34-N-PHT</p> <p>JET SMART CLONE + CRYPTO REQUIRED TO DUPLICATE SEE PAGE 54 FOR REPLACEMENT HEAD AND BLADE</p>
--	---	--	---	---

<p>NISSAN</p>  <p>DA40-PHT</p>	<p>SUBARU</p>  <p>SR8-N-PHT</p> <p>JET SMART CLONE + CRYPTO REQUIRED TO DUPLICATE SEE PAGE 54 FOR REPLACEMENT HEAD AND BLADE</p>	<p>TOYOTA</p>  <p>TR40-PHT</p> <p>ON BOARD PROCEDURE REQUIRED</p>	<p>TOYOTA</p>  <p>TR47-PHT</p> <p>ON BOARD PROCEDURE REQUIRED</p>	<p>TOYOTA</p>  <p>TR47-PHT-LC</p>
---	---	--	--	--

<p>TOYOTA</p>  <p>TR47-N-PHT</p> <p>JET SMART CLONE REQUIRED TO DUPLICATE SEE PAGE 54 FOR REPLACEMENT HEAD AND BLADE</p>	<p>TOYOTA</p>  <p>TR51-N-PHT</p> <p>JET SMART CLONE + CRYPTO REQUIRED TO DUPLICATE SEE PAGE 54 FOR REPLACEMENT HEAD AND BLADE</p>	<p>VW / AUDI</p>  <p>TRYOUT KEY</p> <p>HU66VW-B</p>	<p>VW / AUDI</p>  <p>HU67-PHT</p>	<p>VW / AUDI</p>  <p>HU67-PHT-LC</p>
--	---	---	---	--

Smart Clone

CLONES THE UNCLONABLE

With the new JET "Smart Clone" with Crypto Update (SCLONE-CRPT), you can now clone ALL T.I. Crypto transponder keys as well as ALL Fixed Code transponder keys in your shop. Vehicles not required. Older Smart Clones can be upgraded by ordering the Crypto Update (CRYPTO-SW). Keys are also available in assortments: CRB-A (1 ea. of Crypto blades & 3 SCH-2 heads) & SCB-A (1 ea. of all Smart Clone blades & 2 SCH-1 & 3 SCH-2 heads). Optional software (SC-Console) is also available which allows additional functions including manual writing/generation of codes for fixed code transponder keys & customer archiving.



SMART CLONE TRANSPONDER KEY BLANKS

Unique two piece design... The blade of the SMART CLONE Transponder Key separates from the electronic key head so it can be easily replaced in case of damage or miscut.

 CHRYSLER Y160-N-PHT Replacement Second Generation Universal Electronic Head SCH-2 Replacement Blade Y160-N-B	 FORD H90-N-PHT Replacement Second Generation Universal Electronic Head SCH-2 Replacement Blade H90-N-B	 KIA KK7-N-PHT Replacement Second Generation Universal Electronic Head SCH-2 Replacement Blade KK7-N-B	 LEXUS TR60-N-PHT Replacement Second Generation Universal Electronic Head SCH-2 Replacement Blade TR60-N-B	 MAZDA MZ34-N-PHT Replacement Second Generation Universal Electronic Head SCH-2 Replacement Blade MZ34-N-B
 MITSUBISHI MIT12-N-PHT Replacement Second Generation Universal Electronic Head SCH-2 Replacement Blade MIT12-N-B	 MITSUBISHI MIT13-N-PHT Replacement Second Generation Universal Electronic Head SCH-2 Replacement Blade MIT13-N-B	 NISSAN DA34-N-PHT Replacement Second Generation Universal Electronic Head SCH-2 Replacement Blade DA34-N-B	 SUBARU SR8-N-PHT Replacement Second Generation Universal Electronic Head SCH-2 Replacement Blade SR8-N-B	 TOYOTA TR51-N-PHT Replacement Second Generation Universal Electronic Head SCH-2 Replacement Blade TR51-N-B
 FORD H72-N-PHT Replacement First Generation Universal Electronic Head SCH-1 Replacement Blade H72-N-B	 INFINITI INFQ45-N-PHT Replacement First Generation Universal Electronic Head SCH-1 Replacement Blade INFQ45-N-B	 TOYOTA TR47-N-PHT Replacement First Generation Universal Electronic Head SCH-1 Replacement Blade TR47-N-B	 LEXUS TR48-N-PHT Replacement First Generation Universal Electronic Head SCH-1 Replacement Blade TR48-N-B	 LEXUS TR49-N-PHT Replacement First Generation Universal Electronic Head SCH-1 Replacement Blade TR49-N-B

ONE TRANSPONDER KEY DOES IT ALL!

Guaranteed to work, No Pre-Programming Necessary!
 No need to inventory two different versions of the same key.
 KEY PACKAGING IS CLEARLY MARKED WITH APPLICABLE PROCEDURES

CLONE	ON-BOARD	DIAGNOSTIC TOOLS
B97-PHT B99-PHT B103-PHT B107-N-PHT MAZ24-N-PHT DA31-N-PHT HD106-N-PHT HD110-N-PHT	B97-PHT B99-PHT B103-PHT B107-N-PHT MAZ24-N-PHT	DA31-N-PHT HD106-N-PHT HD110-N-PHT



"Includes Blo-molded Case"



NGS-XL-CAN FORD TRANSPONDER PROGRAMMER

Ford transponder keys for the year 2007 models, and for all prior years, can now be made without an original key. The NGS-XL-CAN plugs into the vehicle and will create a new key. 5 H72-PHT, 5 H72-PHT-T and 5 H74-PHT Ford transponder keys and 50 H75-NP Ford keys are included with the Jet NGS-XL-CAN.

The NGS-XL-CAN will now come with two VIM's (vehicle interface module). The classic VIM, which uses the green and red software cards for 2004 and earlier models and the purple & orange software cards for 2005 and later models, will perform all the necessary functions on 1996-2006 non-CAN vehicles. The NEW CAN VIM, with an additional blue software card, will perform all the necessary functions on 2003 and later vehicles that use the new link.



Personalized Neuter Bow Key Blanks

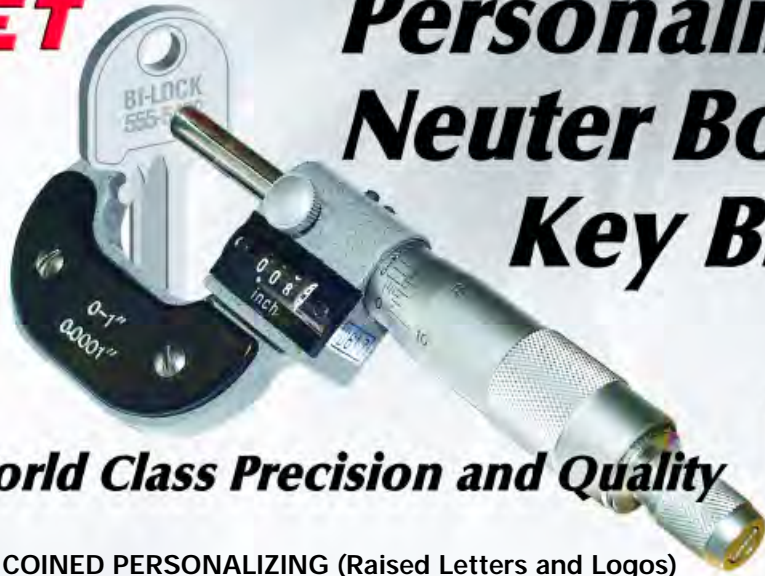

World Class Precision and Quality

- COINED PERSONALIZING (Raised Letters and Logos)
- HIGHEST QUALITY • NEUTER HEAD SHAPE
- NICKEL PLATED BRASS
- MINIMUM 1000 PIECES PER ORDER
- ORDER AS FEW AS 100 PIECES PER BLANK

OPTIONS FOR FRONT OF BLANK SHOWN ACTUAL SIZE

STYLE A: WITH 1/16" TYPE maximum 15 characters per line	STYLE B: WITH 3/32" TYPE maximum 13 characters per line	STYLE C: WITH 1/8" TYPE maximum 11 characters per line

THE FOLLOWING KEY BLANKS ARE AVAILABLE IN THE NEUTER BOW...

NB-AR1	NB-M1	NB-SC9
NB-DE6	NB-SC1	NB-WR3
NB-KW1	NB-SC4	

OPTIONS FOR BACK OF BLANK STOCK COINING DIES

STYLE Z: BLANK	STYLE Y: ALOA LOGO*
STYLE X: DO NOT DUPLICATE	STYLE W: SUPPORT YOUR LOCAL LOCKSMITH
STYLE V: SECURITY	STYLE U: KEY NUMBER
STYLE T: ROOM NUMBER	STYLE S: YOUR SECURITY IS OUR BUSINESS

* NOTE: IF YOU CHOOSE STYLE "Y" ABOVE, YOU MUST PUT YOUR ALOA NO. ON THE ORDER FORM.

JET Exclusive Products

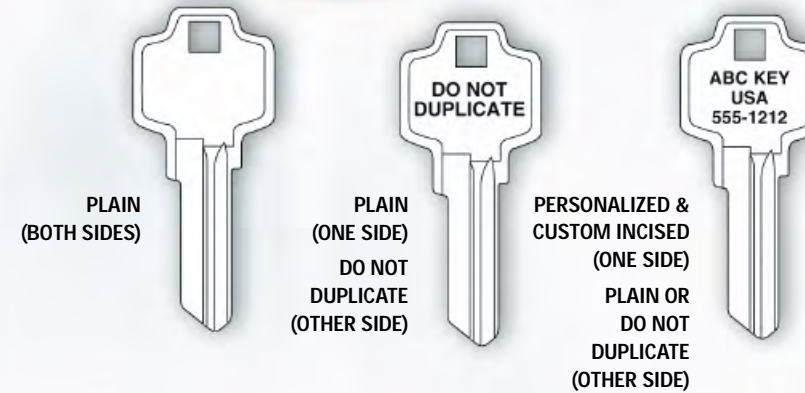

CROSS SECTIONS AVAILABLE IN UNI-BOW LINE			
MFR.	MFR. NO.	JET NO.	X-SECT.
ARROW	K2	AR1	
DEXTER	67	DE6	
KWIKSET	1063KW	KW1	
KWIKSET	8260KW	KW10	
MASTER	1K	M1	
RUSSWIN	6D1	RU46	
SCHLAGE	100-C	SC1	
SCHLAGE	101-C	SC4	
SCHLAGE	100-E	SC8	
SCHLAGE	101-E	SC9	
SEGAL	K9	SE1	
WEISER	P1555	WR5	
YALE	8	Y1	

When ordering UNI-BOW key blanks... Use the JET number and:

- (1) ADD - UN FOR PLAIN BOTH SIDES (e.g.: AR1-UN)
- (2) ADD - UN-DD FOR DO NOT DUPLICATE (e.g.: AR1-UN-DD)
- (3) ADD - UN-PE FOR PERSONALIZED, PLAIN OTHER SIDE (e.g.: AR1-UN-PE)
- (4) ADD - UN-DD-PE FOR PERSONALIZED, DO NOT DUPLICATE OTHER SIDE (e.g.: AR1-UN-DD-PE)

Ditto+ Line

PersonaLine

AN "ORIGINAL" ALTERNATIVE
DITTO+ key blanks are made with the finest quality, solid brass available.
DITTO+ key blanks are the same design as the originals.
DITTO+ key blanks are milled to exact original specifications and tolerances.

- Hundreds of the most popular standard bow key blanks to fit your every need.
- Includes GM, Ford and Chrysler cars.
- For a small added charge, you may have your name and phone number stamped on your key blanks.
- Your own personal identification will create repeat sales.

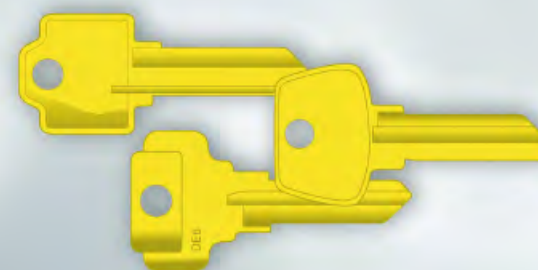



- AVAILABLE IN THE MOST POPULAR KEYWAYS
 - HIGHEST QUALITY BRASS
 - MINIMUM 1000 PIECES PER ORDER
 - ORDER AS FEW AS 100 PIECES PER BLANK FROM THE FOLLOWING "QUICK SHIP" KEYS: CO88, CO91, CR46, CR88, CR91, CR-L4-6, KW1, KW10, KW11, L4-6, RU46, S22-LA, SC1, SC4, SC9, Y1 and Y78.
- Minimum order of 500 pcs. per blank for all other numbers.

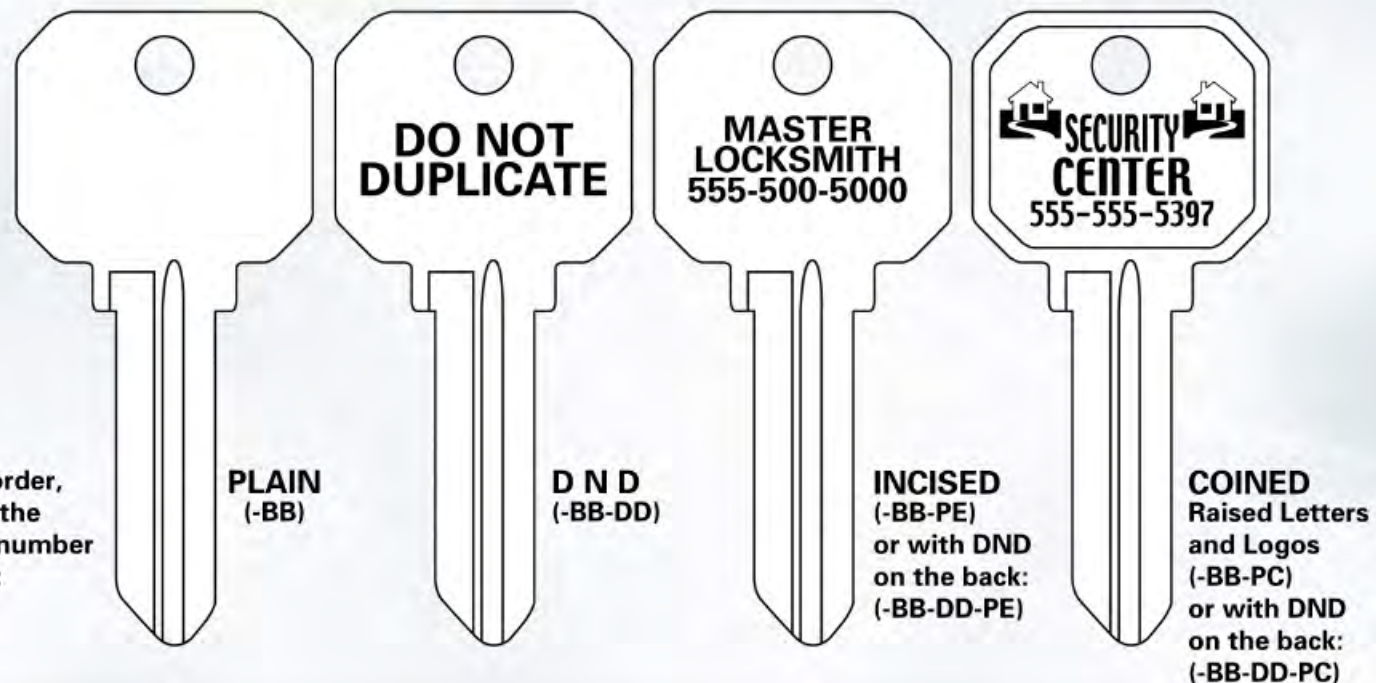

Available in brass

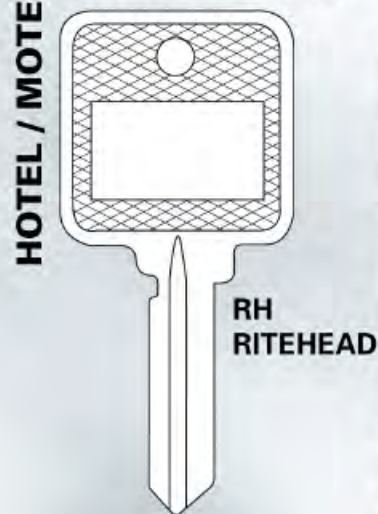

ARROW
AR4-RH
KWIKSET
KW1-RH
SCHLAGE
SC1-RH
SC4-RH
SC9-RH
WEISER
WR3-RH

- ALL SOLID BRASS; 0.55 INCHES THICK
- PACKAGED 100 PIECES PER BOX
- TAGS ARE AVAILABLE IN 4 POPULAR SIZES

HEAVY BRASS KEY TAGS

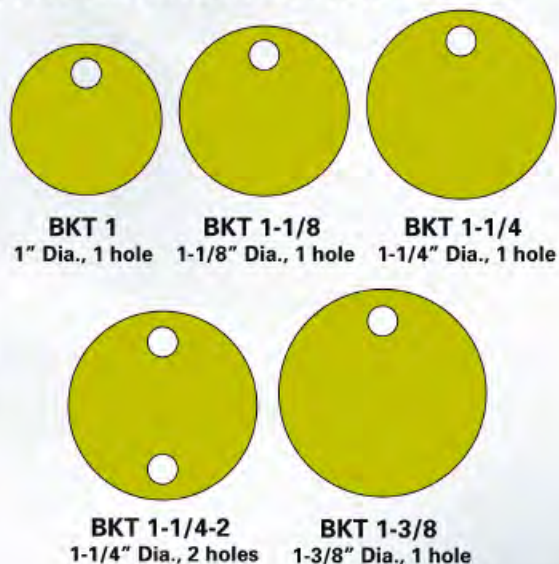

Jet Key Machines
Precision Cuts
Every Time

World Class Precision and Quality



SPECIAL FEATURES - MODEL 7060

- Semi-Automatic... the fastest way to cut a key.
- Momentary Brush Switch... it will stop when your hand is taken off the switch. Brush is made from nylon instead of steel wire and is safe for your hands.
- Overhead light.
- Carriage Auto-Shutoff Safety Switch...when lever is down for key loading or retrieval, cutter will automatically stop for operator safety.
- Heavy Duty Construction... 1/4 horsepower motor for fast reliable key cutting and many years of dependable service.
- Cutter is made from M35 high speed steel.
- Four way jaws to accommodate many house keys, domestic and foreign car keys. Machine will fit under the JET Key Tower.
- Heavy duty cover for quieter operation.

Shipping weight : 50 lbs.

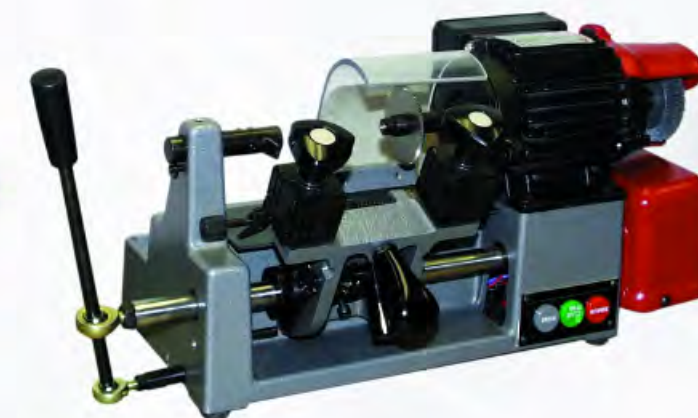

SPECIAL FEATURES - MODEL 7080

- Usable as either fully automatic or semi-automatic for faster and more convenient key copying.
- You can set the machine and walk away... cuts automatically.
- Cycle Time... in automatic mode cuts keys in about 15 seconds.
- Momentary Brush Switch... it will stop when your hand is taken off the switch. Brush is made from nylon instead of steel wire and is safe for your hands.
- Carriage Auto-Shutoff Safety Switch...when lever is down for key loading or retrieval, cutter will automatically stop for operator safety.
- Heavy Duty Construction... 1/4 horsepower motor for fast, reliable key cutting and many years of dependable service.
- Cutter is made from high speed steel.
- Four way jaws to accommodate many house keys, domestic and foreign car keys.
- Machine will fit under the JET Key Tower.

Shipping weight: 54 lbs.

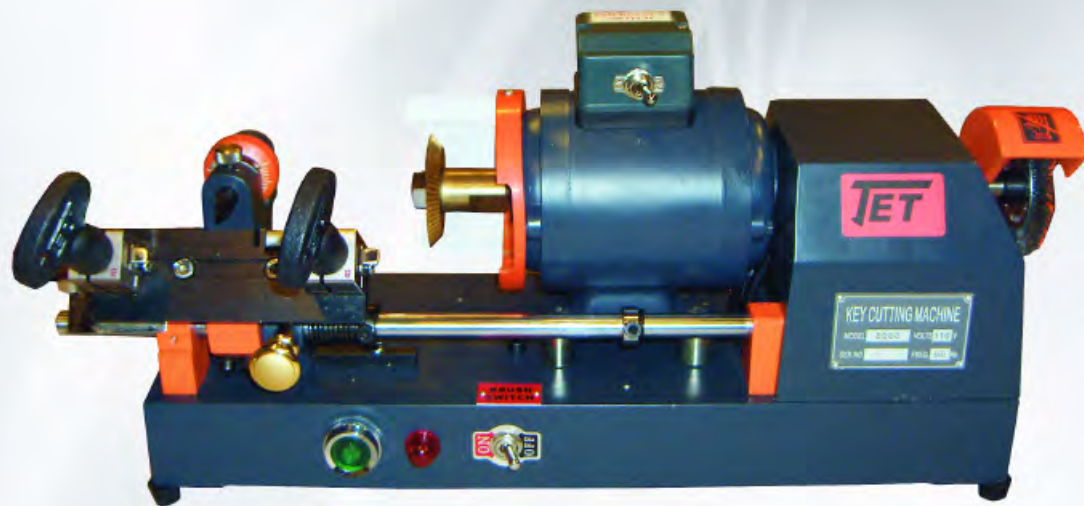

MODEL 8000 FULLY AUTOMATIC

The Model 8000 is a competitively priced key duplicating machine. It is easy to operate and is sized perfectly to fit under the JET Key Tower.

SPECIAL FEATURES - MODEL 8000

- **Vise Jaws...** Two way hardened steel jaws accommodate most popular house, institutional, domestic and foreign car keys.
- **Cutter is made of high speed steel, engineered for cutting high quality brass and nickel silver key blanks.**
- **Set up guides are manually operated and feature a safety factor if accidentally left in place at the time of cutting.**
- **Cycle time in the automatic mode is approximately 7 to 10 seconds.**
- **Nylon brush switch activates the cycle for the same period of time.**
- **Emergency shut off switch is located on top of the motor.**
- **Calibration gauge is a disk type adjustment with hardened steel set screws.**
- **Heavy Duty Construction...** 1/4 horsepower motor for fast, reliable key cutting and many years of dependable service.

Shipping weight: 31 lbs.



CUTTER NUMBER: 11MC
STYLE: MILLING CUTTER
DIAMETER: 2 3/8"
THICKNESS: .280"
HOLE DIAMETER: 1/2"
MAT: HIGH SPEED STEEL
USE ON:
DL144M
DL144MA
ILCO 024
TAYLOR 144MT



CUTTER NUMBER: 26MC
STYLE: MILLING CUTTER
DIAMETER: 3 1/8" - 80MM
THICKNESS: .196" - 5MM
HOLE DIAMETER: .630"
MAT: M35 HIGH SPEED STEEL
USE ON:
BORKEY REXA, ILCO KD40, KD50, KD71
RYTAN RY45, RY100, RY256
JET 7060, 7070
JET 7050 PRO SR.
JET 7040 PRO JR.



CUTTER NUMBER: CU20
STYLE: MILLING CUTTER
DIAMETER: 2 3/8"
THICKNESS: .250"
HOLE DIAMETER: 1/2"
MAT: HIGH SPEED STEEL
USE ON:
ILCO 020, 024A, 024B
ILCO 040
ILCO 044



CUTTER NUMBER: 19MC
STYLE: MILLING CUTTER
DIAMETER: 3 7/8"
THICKNESS: .281"
HOLE DIAMETER: 1/2"
MAT: M2 HIGH SPEED STEEL
USE ON:
ILCO 006, 010
ILCO 2183DM,
ILCO 2183HM
KEIL 1, 1 1/2, 10



CUTTER NUMBER: 34MC
STYLE: MILLING CUTTER
DIAMETER: 2 1/4"
THICKNESS: .250"
HOLE DIAMETER: 1/2"
MAT: M2 HIGH SPEED STEEL
USE ON:
COLE 1000, 3000, 5000
CURTIS 2
DL-147M, 149M
HPC 9100, HPC 9110
ILCO 2585DU, H2584CV, 2584CV
ILCO 2184CD
TAYLOR KD1, KD5, KD20
KEIL 4 1/2, 12 1/2, 13 1/2, 15



CUTTER NUMBER: CW16
STYLE: SLOTTER CUTTER
DIAMETER: 2 1/4"
THICKNESS: .045"
HOLE DIAMETER: 1/2"
MAT: M2 HIGH SPEED STEEL
USE ON:
JET 7010
JET 7020



CUTTER NUMBER: 23MC
STYLE: MILLING CUTTER
DIAMETER: 2 1/4"
THICKNESS: .093"
HOLE DIAMETER: 1/2"
MAT: M2 HIGH SPEED STEEL
USE ON:
JET 7010
JET 7020



CUTTER NUMBER: 60MC
STYLE: MILLING CUTTER
DIAMETER: 60MM
THICKNESS: 6MM
HOLE DIAMETER: 16MM
MAT: HIGH SPEED STEEL (HSS)
USE ON:
JET 8000



CUTTER NUMBER: P9MC
STYLE: MILLING CUTTER
DIAMETER: 2 7/8"
THICKNESS: .208"
HOLE DIAMETER: 1/2"
MAT: HIGH SPEED STEEL
USE ON:
ILCO 016
ILCO 017
ILCO 018



CUTTER NUMBER: X23MC
STYLE: MILLING CUTTER
DIAMETER: 2 3/8"
THICKNESS: .093"
HOLE DIAMETER: 1/2"
MAT: M2 HIGH SPEED STEEL
USE ON:
DL143M, 145, 145M,
DL148M
HPC 9160MC, 9180MC
ILCO 023, 025, 045
TAYLOR 143MT, 145MT



CUTTER NUMBER: 23RF
STYLE: ROTARY FILE
DIAMETER: 2 1/4"
THICKNESS: .250"
HOLE DIAMETER: 1/2"
MAT: W2
USE ON:
CURTIS 2
DL-145, 145M, 147M, 149M
HPC 9100, HPC 9110
ILCO 2585DU, H2584CV
ILCO 2184CD, 008, 190
TAYLOR KD1, KD5, KD20
KEIL 4 1/2, 12 1/2, 13 1/2, 15



CUTTER NUMBER: 75MC
STYLE: MILLING CUTTER
DIAMETER: 75MM
THICKNESS: 5MM
HOLE DIAMETER: 10MM
MAT: HIGH SPEED STEEL
USE ON:
JET 7080
JET 7090



TYLON 3" BRUSH
7120, 50-200
USE ON:
JET 7010
JET 7020
JET 7080
JET 7090
JET 8000

TYLON 3" BRUSH
7160-200
USE ON:
JET 7060
JET 7070

KEY TOWER "7001"



The JET Key Tower Display is the perfect way to merchandise your key duplicating service to your customers. The attractive, colorful header towers over 40-inches above the counter, making it easily seen from points throughout your store.

The four-sided rotary key display rack features 342 key blank hooks and allows for quick, easy selection and duplication of key orders. Preprinted location cards slip behind the hook racks for easy placement and retrieval of key blanks, and for effective inventory control. An easily accessed storage door in the tower provides for convenient key blank storage.

The key machine, ordered separately, fits neatly into the base of the display, providing an attractive, self-contained key duplication center. The display's small foot print utilizes only 2 square feet of counter space.

PBA-176
KEY TOWER "7001" ASSORTMENT
 176 most popular residential, commercial and padlock key blanks. Also, domestic and foreign auto key blanks.
 Total of 915 pieces

TOWER PANELS 7001-PC
 Four colorful panels with preprinted key location numbers.



WINDOW DECAL 7000-W
 Included FREE with the Key Tower "7001": a colorful window/door decal to help promote key sales.



KEY SIGN 7001-S
 Ideal for window or outdoor promotion of key cutting service. Made of plastic laminate, this sign is die cut in the shape of a key and printed in bright colors. Measures: 34" X 14".

"Flip-Over-Board"



One side for home and auto key assortments



Flip-over for Jet Groovy Key assortments

MODEL 3000-FO Jet Keyboard Display is our new, unique wall-mount key blank display rack. This two-sided **FLIP-OVER-BOARD** display holds up to 112 different key blanks in assortments that match your customer demand. The Keyboard features Home and Auto graphics on one side and Groovy Key graphics on the flip side. It's pre-drilled with 3/16 - inch holes on 1-inch centers to accept standard pegboard accessories. Supplied with 56 dual key hooks, each is capable of holding up to 19 keys - a total of 2128 keys.

SQUAROUSEL DISPLAY MODEL 2000

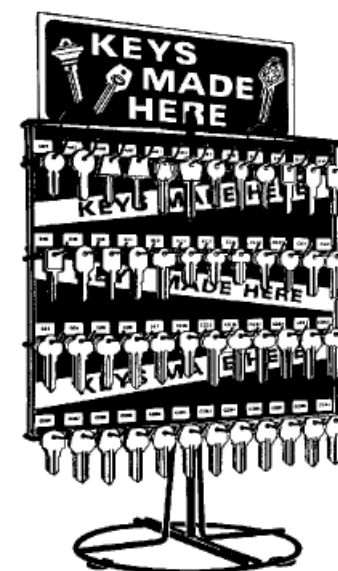

The Squarousel is Jet Hardware's unique double-sided point-of-sale key rack and bench display. It holds up to 96 types of the key blanks most often requested by your customers. The Jet Squarousel is constructed of 3/16 -inch steel rod and pivots through 360° on a stable circular base with three flange mounts for security. Supplied with the Squarousel are pre-printed, self-adhesive key blank identification labels that you apply yourself.

- COLORFUL, COMPACT DISPLAY REQUIRES ONLY 14-INCHES OF COUNTER SPACE
- CUSTOM DESIGN YOUR KEYBOARDS WITH SELF-ADHESIVE LABELS THAT YOU APPLY TO FIT YOUR OWN ASSORTMENT
- ONLY TWO ROTATING PANELS... KEYS ARE EASILY LOCATED
- WELDED KEY HOOKS PROVIDE OPEN DISPLAY FOR 96 DIFFERENT KEYS, WITH STORAGE CAPACITY OF 18 KEYS PER HOOK
- DISPLAYS MORE THAN 1,700 KEYS

KEY BLANK ASSORTMENT KITS FOR JET DISPLAYS

ABA-31
AUTOMOTIVE BLANK ASSORTMENT
 17 Domestic and 14 nickel-plated Foreign auto blanks.

ABA-F-31 Same as above, with Keyboard
 10 per poly bag
 Total of 310 pieces

CBA-51
COMMERCIAL ASSORTMENT
 51 assorted keys, including 6-pin, 7-pin and nickel-silver key blanks.
CBA-F-51 Same as above, with Keyboard
 5 per poly bag
 Total of 255 pieces

FBA-46
FOREIGN AUTOMOTIVE BLANK ASSORTMENT
 46 nickel-plated Foreign auto key blanks.
FBA-F-46 Same as above, with Keyboard
 10 per poly bag
 Total of 460 pieces

HBA-65
HOUSE AND PADLOCK ASSORTMENT
 65 most popular numbers.
HBA-F-65 Same as above, with Keyboard
 5 per poly bag
 Total of 325 pieces

PBA-70
POPULAR HOUSE, PADLOCK, AUTO BLANK ASSORTMENT
 70 most popular house, padlock and domestic auto key blanks.
PBA-F-70 Same as above, with key-board
 5 per poly bag
 Total of 350 pieces

JET	ILCO	EZ	STAR	PAGE	JET	ILCO	EZ	STAR	PAGE
057AD-6-NP	-	-	-	8	11-SC-NS	998SC (NP)	-	-	20/26
059AD-6	A1001GRM	-	-	8	11-SD-NS	998SD (NP)	-	-	20/26
059AD-7	L1001GRM	-	-	8	11-SE-NS	998SE (NP)	-	-	20/26
1A1A1-NS	A1114A	-	-	5/24	11-SF-NS	998SF (NP)	-	-	20/26
1A1A1B-NS	-	-	-	5/24	11-SG-NS	998SG (NP)	-	-	20/26
1A1B1-NS	A1114B	-	-	5/24	11-SH-NS	998SH (NP)	-	-	20/26
1A1B1B-NS	-	-	-	5/24	11-SK-NS	998SK (NP)	-	-	20/26
1A1BA1-NS	-	-	-	5/23	11-SMK-NS	998SMK (NP)	-	-	20/26
1A1C1-NS	A1114C	-	-	5/24	19-NS	SX9B (NP)	-	-	19/26
1A1C1B-NS	-	-	-	5/24	54G	1054G	-	-	10
1A1D1-NS	A1114D	-	-	5/24	57A1-6-NS	R1001EE-NP	-	-	9/24
1A1D1B-NS	-	-	-	5/24	57A2-6-NS	1001MB-NP	-	-	9/24
1A1DD1-NS	A1114DD	-	-	5/24	57B1-6-NS	1001MA-NP	-	-	9/24
1A1DD1B-NS	-	-	-	5/24	57B2-6-NS	R1001ED-NP	-	-	9/24
1A1DE1-NS	-	-	-	5/23	59A1-6-NS	A1012-59A1	-	-	9/24
1A1E1-NS	A1114E	-	-	5/24	59A2-6-NS	A1012-59A2	-	-	9/24
1A1E1B-NS	-	-	-	5/24	59B1-6-NS	A1012-59B1	-	-	9/24
1A1F1-NS	A1114F	-	-	5/24	59B2-6-NS	A1012-59B2	-	-	9/24
1A1F1B-NS	-	-	-	5/24	59C1-6-NS	A1012-59C1	-	-	9/24
1A1G1-NS	A1114G	-	-	5/24	59C2-6-NS	A1012-59C2	-	-	9/24
1A1G1B-NS	-	-	-	5/24	59D1-6-NS	A1012-59D1	-	-	9/24
1A1H1-NS	A1114H	-	-	5/24	59D2-6-NS	A1012-59D2	-	-	9/24
1A1H1B-NS	-	-	-	5/24	60-6-NS	A1012-60	-	-	9/24
1A1J1-NS	A1114J	-	-	5/24	77-6-NS	R1001EG	-	-	8/24
1A1J1B-NS	-	-	-	5/24	100-C-DD-NS	1145	-	-	16/26
1A1JK1-NS	-	-	-	5/23	100-C-NP	100C	-	-	17
1A1K1-NS	A1114K	-	-	5/24	100-C-NS	100C-NS	-	-	17/26
1A1K1B-NS	-	-	-	5/24	100-E-NS	100E-NS	-	-	17/26
1A1L1-NS	A1114L	-	-	5/24	100-F-NS	1145F	-	-	17/26
1A1L1B-NS	-	-	-	5/24	100-L-NS	1145L	-	-	17/26
1A1M1-NS	A1114M	-	-	5/24	101-C-NP	101C	-	-	17
1A1M1B-NS	-	-	-	5/24	101-C-NS	101C-NS	-	-	17/26
1A1N1-NS	-	-	-	5/24	101-CE-NS	A1145CE, 101CE-NS	-	-	17/26
1A1N1B-NS	-	-	-	5/24	101-E-NP	101E	-	-	17
1A1O1-NS	A1114O	-	-	5/24	101-E-NS	101E-NS	-	-	17/26
1A1O1B-NS	-	-	-	5/24	101-EF-NS	A1145EF, 101EF-NS	-	-	17/26
1A1R1-NS	A1114R	-	-	5/24	101-F-NS	101F-NS	-	-	17/26
1A1R1B-NS	-	-	-	5/24	101-FG-NS	A1145FG	-	-	17/26
1A1TB1-NS	A1114TB	-	-	5/24	101-G-NS	A1145G	-	6SH7	17/26
1A1TB1B-NS	-	-	-	5/24	101-H-NS	A1145H	-	-	17/26
1A1TD1-NS	-	-	-	5/24	101-L-NS	A1145L	-	-	17/26
1A1TE1-NS	-	-	-	5/24	137B	1137B	-	-	4/20/36
5SE3	-	-	5SE3	17	137S	1137S	-	-	4/20/36
6SE4	1022H	-	6SE4	17	191	VR91AR	VR7	5VR3	18
8-NP	999 (NP)	-	-	19	191B	VR91B	VR5	5VR4	18
8-NS	8-YALE-NS	-	-	19/26	275LE-NS	1007LE	-	-	15/25
11-GA-NP	998GA (NP)	-	-	19	275RE-NS	1007RE	-	-	15/25
11-GA-NS	998GA (NP)	-	-	20/26	275RF-NS	1007RF	-	-	16/25
11-GB-NS	998GB (NP)	-	-	20/26	275RG-NS	1007RG	-	-	16/25
11-GC-NS	998GC (NP)	-	-	20/26	1063KW-BR	1063KW-BR	KW1	5KW1	12
11-GD-NS	998GD (NP)	-	-	20/26	1063KW-NP	1063KW	KW1	5KW1	12
11-GE-NS	998GE (NP)	-	-	20/26	6270LD-NS	O1007LD	-	-	16/25
11-GF-NS	998GF (NP)	-	-	20/26	6270LH-NS	O1007LH	-	-	16/25
11-GG-NS	998GG (NP)	-	-	20/26	6270LM-NS	O1007LM	-	-	16/25
11-GH-NS	998GH (NP)	-	-	20/26	6270LN-NS	N1007KMA	-	-	16/25
11-GK-NS	998GK (NP)	-	-	20/26	6270RD-NS	O1007RD	-	-	16/25
11-GMK-NS	998 (NP)	-	-	20/26	6270RH-NS	O1007RH	-	-	16/25
11-NP	999A (NP)	-	-	19	6270RM-NS	O1007RM	-	-	16/25
11-NS	999A (NP)	-	-	19/26	6270RN-NS	N1007RMA	-	-	16/25
11-SA-NS	998SA (NP)	-	-	20/26	6275LA-NS	6275LA	-	-	16/25
11-SB-NS	998SB (NP)	-	-	20/26	6275LB-NS	O1007LB	-	-	16/25

JET	ILCO	EZ	STAR	PAGE	JET	ILCO	EZ	STAR	PAGE
6275LC-NS	O1007LC	-	-	16/25	B46-PH	-	-	-	45
6275LE-NS	O1007LE	-	-	16/25	B47	S1098K	B47	OBR10K	33
6275LF-NS	O1007LF	-	-	16/25	B47-NP	S1098K	B47	OBR10K	33
6275LG-NS	O1007LG	-	-	16/25	B47-PH	-	-	-	45
6275LJ-NS	O1007LJ	-	-	16/25	B48	P1098A	B48	HBR12A	33
6275LK-NS	O1007LK	-	-	16/25	B48-NP	P1098A	B48	HBR12A	33
6275LL-NS	O1007LL	-	-	16/25	B48-PH	B48-P	B48-P	-	45
6275RA-NS	O1007RA	-	-	16/25	B49	S1098B	B49	OBR12B	33
6275RB-NS	O1007RB	-	-	16/25	B49-NP	S1098B	B49	OBR12B	33
6275RC-NS	O1007RC	-	-	16/25	B49-PH	B49-P	B49-P	-	45
6275RE-NS	O1007RE	-	-	16/25	B50	P1098C	B50	HBR14C	33
6275RF-NS	O1007RF	-	-	16/25	B50-NP	P1098C	B50	HBR14C	33
6275RG-NS	O1007RG	-	-	16/25	B50-PH	B50-P	B50-P	-	45
6275RJ-NS	O1007RJ	-	-	16/25	B51	S1098D	B51	OBR14D	33
6275RK-NS	O1007RK	-	-	16/25	B51-NP	S1098D	B51	OBR14D	33
6275RL-NS	O1007RL	-	-	16/25	B51-PH	B51-P	B51-P	-	45
8260KW-NS	08260KW	-	-	12/25	B52	1098GX	B52	-	30
A191-NP	AG2	-	-	13	B52-NP	1098GX	B52	-	30
A192-NP	A192	-	-	13	B53-NP	X143	B53	SP1	34/39
AB1	AB62C	-	-	4	B54-NP	X154	B54	-	34/39
AB2	AB62CR	-	-	4	B55-NP	X145	B55	-	34
AB3	AB62ER	-	-	4	B56-NP	X146	B56	-	34
AB4	AB62E	-	-	4	B59-NP	X162	B59	-	34
AIR-5-BR	1515	-	5ME1	14	B61-NP	X168	B61	-	34
AIR-5-NS	1515	-	5ME1	14/25	B62	P1098AV	B62	HBR15A	34
AIR-6-BR	A1515	-	6ME1	14	B62-NP	P1098AV	B62	HBR15A	34
AIR-6-NS	A1515	-	6ME1	14/25	B62-P1	B62-P1	-	-	45
AM1	1041C	AM1	JU1	4	B62-P2	B62-P2	-	-	45
AM3	1046	AM3	5JU2	4	B62-P3	B62-P3	-	-	45
AM6	1045	AM3	5AM1	4	B62-P4	B62-P4	-	-	45
AM6-L	-	-	-	4	B62-P5	B62-P5	-	-	45
AM7	A1045	-	6AM1	4	B62-P6	B62-P6	-	-	45
AR-1C-NS	B1179-1C	-	-	4/23	B62-P7	B62-P7	-	-	45
AR-1D-NS	B1179-1D	-	-	4/23	B62-P8	B62-P8	-	-	45
AR-ER	A1019M	-	6AR3	4	B62-P9	B62-P9	-	-	45
AR1	1179	AR1	5AR2	4	B62-P10	B62-P10	-	-	45
AR3	N1179A	-	-	4	B62-P11	B62-P11	-	-	45
AR4	1179A	AR4	6AR2	4	B62-P12	B62-P12	-	-	45
AR4-RH	1179A-HA	-	-	58	B62-P13	B62-P13	-	-	45
AUT1-NP	1611R	-	-	30	B62-P14	B62-P14	-	-	45
B1	1098M	B1	OBR1	30	B62-P15	B62-P15	-	-	45
B1-NP	1098M	B1	OBR1	30	B63-NP	P1098CV	B63	HBR15C	34
B2	H1098M	B2	HBR1	30	B64-NP	P1098WC	B64	GM64C	34
B2-NP	H1098M	B2	HBR1	30	B65-NP	X184	B65	-	34/39
B4	1098XL	B4	OBR3	30	B67-NP	S1098WD	B67	GM67D	34
B4-NP	1098XL	B4	OBR3	30	B68-NP	P1099	B68	GM68	34
B5	1098DB	B5	OBR1DB	30	B69-NP	X180	B69	-	34
B5-NP	1098DB	B5	OBR1DB	30	B72-NP	X192	B72	-	34
B10	H1098LA	B10	HBR2	33	B74-NP	X198	B74	-	39
B10-NP	H1098LA	B10	HBR2	33	B76-NP	P1100	B76	SAT91	34
B11	O1098LA	B11	OBR2	33	B77-NP	P1098EV	B77	HBR15E	35
B11-NP	O1098LA	B11	OBR2	33	B78-NP	P1098WE	B78	GM78E	35
B15-NS	-	-	B15	33	B79-NP	S1098WH	B79	GM79H	35
B44	P1098E	B44	HBR9E	33	B80-NP	X225	B80	-	35
B44-NP	P1098E	B44	HBR9E	33	B82	P1102	B82	-	35
B44-PH	B44-P	B44-P	-	45	B82-NP	P1102	B82	-	35
B45	S1098H	B45	OBR9H	33	B82-PH	B82-P	B82-P	-	45
B45-NP	S1098H	B45	OBR9H	33	B82-P2	B82-P2	-	-	45
B45-PH	B45-P	B45-P	-	45	B82-P3	B82-P3	-	-	45
B46	P1098J	B46	HBR10J	33	B82-P4	B82-P4	-	-	45
B46-NP	P1098J	B46	HBR10J	33	B82-P5	B82-P5	-	-	45

JET	ILCO	EZ	STAR	PAGE	JET	ILCO	EZ	STAR	PAGE
B82-P6	B82-P6	-	-	45	CB9-NP	1589I	CLB9	CB9	31
B82-P7	B82-P7	-	-	45	CB10-NP	1589J	CLB10	CB10	31
B82-P8	B82-P8	-	-	45	CB11-NP	1590K	CLB11	-	31
B82-P9	B82-P9	-	-	45	CB12-NP	1591L	CLB12	-	31
B82-P10	B82-P10	-	-	45	CB13-NP	1591M	CLB13	-	31
B82-P11	B82-P11	-	-	45	CB14-NP	1591N	CLB14	-	31
B82-P12	B82-P12	-	-	45	CB15-NP	1591P	CLB15	-	31
B82-P13	B82-P13	-	-	45	CB16-NP	-	-	-	31
B82-P14	B82-P14	-	-	45	CB17-NP	-	-	-	31
B82-P15	B82-P15	-	-	45	CCL1-NP	CB3	-	-	6
B83	P1103, P1107	B83, B89	-	35	CG1	1041G	CG1	CG1	6
B83-NP	P1103, P1107	B83, B89	-	35	CG2	1041GA	CG2	CG6	6
B84-NP	P1101	B84	-	35	CG4	1041GR	-	CG2	6
B85-NP	S1105	B85	-	35	CG16	1041T	CG16	5CG7	6
B86	P1106	B86	-	35	CG22	1041E	CG22	5CG5	6
B86-NP	P1106	B86	-	35	CL1	1023	CL1	5CL1	7
B86-PH	B86-P	B86-P	-	45	CLP1-NP	1537	-	-	7
B88-NP	P1108	B88	-	35	CO1	1000	CO1	5CO3	7
B89	P1107	B89	-	35	CO2	1000AB	-	6CO3	7
B89-NP	P1107	B89	-	35	CO2L	-	-	-	10
B89-PH	B89-P	B89-P	-	45	CO3	1001EB	CO3	5CO2	7
B91	P1111	B91	-	35	CO4	1001EA	CO4	6CO2	7
B91-NP	P1111	B91	-	35	CO5	1001	CO5	5CO4	7
B91-PH	B91-P	B91-P	-	45	CO6	1001AB	-	-	7
B92	P1109	B92	-	35	CO7	1001EN	CO7	5CO1	7
B92-NP	P1109	B92	-	35	CO10	X1000G	CO10	5CO6	6
B93	P1112	B93	-	35	CO17	SX1000F	CO17	6CO6	6
B93-NP	P1112	B93	-	35	CO19	X1000F	CO19	6CO10	6
B96-NP	P1110	B96	-	35	CO26	1000V	CO26	1CO7	7
B96-PH	B96-P	B96-P	-	46	CO33	1001E	-	7CO2	7
B97-PHT	B97-PT, B97-PT5	-	-	50	CO36	1001EG	CO36	6CO1	7
B98V-PHT	B98-PT	-	-	50	CO37	1001EL	-	7CO1	7
B99-PHT	B99-PT, B99-PT5	-	-	50	CO51	A1001D1	CO107	-	7
B100V-PHT	B100-PT	-	-	50	CO52	A1001D2	CO108	-	7
B102	P1113	B102	-	36	CO54 1/2	X1000FR	CO54 1/2	6CO14	6
B102-NP	P1113	B102	-	36	CO62	R1001EG	CO62	6CO5	7
B102-PH	B102-P	B102-P	-	46	CO68	S1000V	CO68	CO7	7
B103-PHT	B103-PT, B103-PT5	-	-	50	CO87	1001EH	CO87	5CO11	7
B106-NP	-	-	-	36	CO88	A1001EH	CO88	6CO11	7
B107-PHT	PT04-PT	-	-	50	CO89	A1001ABM	CO89	6CO12	7
B107-N-PHT	PT04-PT5	-	-	50	CO90	1001ABM	-	5CO12	7
B108-NP	P1114	B110	-	36	CO91	A1001AH	CO91	-	7
B108-PH	B110-P	B110-P	-	46	CO92	A1001FH	CO92	-	7
B109-NP	-	-	-	36	CO94	A1001BH	CO94	-	7
B112-CP-PHT	B111-PT	-	-	51	CO95	A1001DH	CO95	-	7
BAL-1-NS	1510	-	-	4/23	CO97	1001GH	CO97	5CO13	7
BAU1	1618	-	-	5	CO98	A1001C1	CO98	-	7
BE2	A1114A	BE2	6BE1	5	CO99	A1001C2	CO102	-	7
BL1-NP	-	-	-	5	CO-KW1	1001MK	-	-	12
BMW1-NP	BMW1	BMW1	-	37	CO-LO	-	-	-	8
BMW3-NP	X144	BMW3	-	37	CON1	-	-	-	36
BMW3-PH	BMW3-P	BMW3-P	-	44	CR-L4-5	1011-L4	-	-	8
BN1-NP	K1122D	BN1	BN1	5	CR-L4-6	A1011-L4	RU101	-	8
CB1-NP	1573A	CLB1	CB1	31	CR-L41-6	A1011-L41	-	-	8
CB2-NP	1573B	CLB2	CB2	31	CR45	1012-D1	CR45	-	8
CB3-NP	1573C	CLB3	CB3	31	CR46	A1012-D1	CR46	-	8
CB4-NP	1573D	CLB4	CB4	31	CR87	1012-60	CR87	-	8
CB5-NP	1573E	CLB5	CB5	31	CR88	A1012-60	CR88	-	8
CB6-NP	1573F	CLB6	CB6	31	CR91	A1012-59A1	CR91	-	8
CB7-NP	1581G	CLB7	CB7	31	D1-6-NS	A1012-D1	-	-	8/24
CB8-NP	1581H	CLB8	CB8	31	D2-6-NS	A1012-D2	-	-	8/24

JET	ILCO	EZ	STAR	PAGE	JET	ILCO	EZ	STAR	PAGE
D3-6-NS	A1012-D3	-	-	8/24	FF1-NP	-	-	-	10
D4-6-NS	A1012-D4	-	-	8/24	FOA-1	FOA-1	-	-	33
D4300	1646	-	-	14	ET36-NP	F44/NE9	-	5FT1	37
D4301	1646R	-	-	14	ET37-NP	FT37	FT37	FT3	37/43
D8780	S1069G	-	-	14	ET38-NP	FT38	FT38	FT2	37/43
D8781	S1069M	-	-	14	ET46-NP	X152	FT46	-	37/43
D8782	1069S	-	-	14	GAS	1098M	B1	-	30
D8783	1069G	RO7	RO3, RO5	14	GAS-NP	1098M	B1	-	30
D8784	1069M	RO5	-	14	GMT265-PHT	-	-	-	51
D8785	1069N	RO3	RO6	14	GMX222CP-PHT	-	-	-	51
D8787	1069FL	RO4	-	14	GMX272CP-PHT	-	-	-	51
D8788	-	-	-	14	GMX320-PHT	-	-	-	51
D8789	1069E, 1069	RO14, RO1	-	14	GMX367-PHT	-	-	-	51
DA21-NP	X7	62DU	DA3	40	GMX380-PHT	-	-	-	51
DA21-PH	-	-	-	47	GMX380CP-PHT	-	-	-	51
DA22-NP	X6	62DT	DA4	40	GMX381-PHT	-	-	-	51
DA23-NP	X115	DA23	DA6	40/41	GMX381CP-PHT	-	-	-	51
DA24-NP	X114	DA24	DA7	40	H1-6-NS	A1012-H1	-	-	8/24
DA25-NP	X123	DA25	DA5	41	H2-6-NS	A1012-H2	-	-	8/24
DA25-PH	DA25-P	DA25-P	-	47	H3-6-NS	A1012-H3	-	-	8/24
DA28-NP	X124	DA28	-	41	H4-6-NS	-	-	-	8/24
DA31-NP	X210	DA31	-	41	H5-6-NS	A1012-H5	-	-	8/24
DA31-PH	DA31-P	DA31-P	-	47	H6-6-NS	A1012-H6	-	-	8/24
DA31-N-PHT	NSN11T2	-	-	53	H7-6-NS	A1012-H7	-	-	8/24
DA34-NP	X237	DA34	-	41	H8-6-NS	A1012-H8	-	-	8/24
DA34-PH	DA34-P	DA34-P	-	47	H50	S1167FD	H50	OFD10	32
DA34-PHT	NI01T, NI02T	-	-	53	H50-NP	S1167FD	H50	OFD10	32
DA34-PHT-LC	-	-	-	53	H51	1167FD	H51	HFD10	32
DA34-N-PHT	NI01-EK	-	-	53	H51-NP	1167FD	H51	HFD10	32
DA37-NP	X242	DA37	-	41	H54	1184FD	H54	HFD12	32
DA37-PH	DA37-P	DA37-P	-	47	H54-NP	1184FD	H54	HFD12	32
DA40-PHT	NI04T	-	-	53	H55	1185FD	H55	HFD11	32
DC2-NP	X54	DC1	LDC1	31	H55-NP	1185FD	H55	HFD11	32
DC3-NP	X121	DC3	-	31/39/40/41	H56-NP	1186TS	H56	-	32
DE6	D1054K	DE6	5DE3	9	H56-PH	1186TS-P	1186TS-P	-	44
DE8	D1054KA	DE8	6DE3	9	H59-NP	X202	H59	-	32
DE-LO	-	-	-	9	H60	1190LN	H60	HFD12L	32
DIE-1-NS	1028L	-	-	26/28	H60-NP	1190LN	H60	HFD12L	32
DIE-2-NS	1052A	-	-	26/28	H62-NP	1191ET	H62	-	32
DIE-3-NS	1028	-	-	26/28	H62-PH	H62-P	H62-P	-	45
DO6-NP	DO6	-	-	9	H65	X221	H65	-	32
DW47-PH	DW05AP	-	-	44	H65-NP	X221	H65	-	32
DW47-N-PHT	DW05T5	-	-	49	H65-PH	H65-P	H65-P	-	45
DW47R-PH	DW05RAP	-	-	44	H66-NP	1193MU	H66	-	33
DW47R-N-PHT	DW05RT5	-	-	49	H67	1193FD	H67	-	33
DW48R-PH	DW04RAP	-	-	44	H67-NP	1193FD	H67	-	33
DW48R-N-PHT	DW04RT5	-	-	49	H67-PH	H67-P	H67-P	-	45
E42DN	1548	-	-	6	H70-NP	X231	H70	-	33
EA27	X1014F, X1014L	EA27, LO1	5EA1	9	H71	1195FD	H71	-	33
EA47	O1014S	-	EA6	9	H71-NP	1195FD	H71	-	33
EM1	1528	-	-	10	H72-PHT	H72-PT	-	-	49
EM1R	1528R	-	-	10	H72-PHT-T	H72-PT-CLEAR	-	-	50
ES1	1556	-	-	9	H72-PHT-LC	-	-	-	50
ES8	1502	-	-	9/30	H72-N-PHT	H72-EK	-	-	50
ES8M	1502M	-	-	9	H73-PHT	H73-PT	-	-	50
ES9	1503	ES9	5ES1	9	H74-PHT	H74-PT	-	-	50
EZ1-NP	1522	EZ1	-	13	H75	1196FD	H75	-	33
FA1	1054WC	FA1	-	10	H75-NP	1196FD	H75	-	33
FA2	A1054WC	FA2	-	10	H75-PH	H75-P	H75-P	-	45
FA3	A1054WD	FA3	-	10	H76	X244	H76	-	33
FC7-NP	X86	FC7	CP4	32/37	H76-NP	X244	H76	-	33

JET	ILCO	EZ	STAR	PAGE	JET	ILCO	EZ	STAR	PAGE
H76-PH	H76-P	H76-P	-	45	IL210M	S1042ZM	-	-	11
H78	1196CM	H78	-	33	IL220	S1042ZS	-	-	11
H78-NP	1196CM	H78	-	33	IL260	1043D	-	IS3	11
H84-PHT	-	-	-	50	IL360	1043B	IL9	IS2	11
H86-PHT	H86-PT	-	-	50	IL510	1042A	-	-	11
H90-N-PHT	H84-EK	-	-	50	IL610	1042B	-	-	11
HD70.71-NP	X71	HD70U	HN2-3	37	ILC-1-NS	1333	-	-	27/28
HD74-NP	X84	HD74	HN5	38	IN1	1054F	IN1	5IL1	11
HD75-NP	X138	HD75	-	38	IN3	X1054K	IN3	5IL4	11
HD82-NP	X129	HD82	HN6	37	IN8	L1054B	IN8	IL5	11
HD83.90-NP	X128, X181	HD90	LHN6, HN90	38	IN18	X1054F	IN18	5IL7	11
HD83.90-PH	HD83.90-P	HD90-P	-	46	IN20	1054K	-	5IL2	11
HD84.92-NP	X165, X183	HD92	-	37	IN28	1054FN	IN28	5IL9	11
HD91-NP	X182	HD91	HN7	38	IN29	1054UN	IN29	IL10UN	11
HD91-PH	HD91-P	HD91-P	-	46	IN33	1054MT	IN33	5IL11	11
HD96-NP	X193	HD96	-	37	IN35	1054DL	IN35	-	11
HD98-NP	X195	HD98	HN98	38	INFO45-PHT	-	-	-	52
HD103-NP	X214	HD103	-	38	INFO45-N-PHT	-	-	-	51
HD103-PH	HD103-P HD110-P	HD103-P HD110-P	-	46	K1	1079	K1	5KE2	12
HD106-N-PHT	HD106-PT HD106-PT5	-	-	51	K2	1079B	K2	5KE1	12
HD106-PHT-LC	-	-	-	51	K6-NS	-	-	-	4/23
HD110-B	HO01-SVC	-	-	51	K7-NS	K7	-	-	4/23
HD110-N-PHT	HO01T5, HO01-PT	-	-	51	K100M	100AM	AP5	CG3	6
HHM-1-NS	1028N	-	-	26/28	K101	101AM	AP1	-	6
HHM-2-NS	1133	-	-	26/28	K101H-NP	-	-	-	6
HK1	1597	HAW1	-	10	K102	102AM	AP2	-	6
HK2	1598	HAW2	-	10	K102H-NP	-	-	-	6
HK3	1599	HAW3	-	10	K103	103AM	AP3	-	6
HK4	1600	HAW4	-	10	K103H-NP	-	-	-	6
HL1	1003M	CO106	5AU1	10	K104	104AM	AP4	-	6
HL1-M	-	-	5HL1	10	K104H-NP	-	-	-	6
HL2	R1003M	BO1	5BO1	6	KA14-NP	X103	KA14	-	39
HR1	1014C	HR1	5HR1	10	KA15-NP	X106	KA15	-	39
HR2	TE3	HR2	5HR2	10	KB577E-NS	P1577F	-	-	10/25
HU66VW-B	-	-	-	53	KB577F-NS	A1054WF(NP)	-	-	10/25
HU66VW-N-PHT	HU66AT2,T5	-	-	49	KB577G-NS	KB1577G	-	-	10/25
HU66VW-PH	HU66-P, A-P	-	-	48	KB577J-NS	A1054WJ(NP)	-	-	10/25
HU67-PHT	HU66T6,AT6	-	-	53	KK1-NP	X233	KK1	-	39
HU67-PHT-LC	-	-	-	53	KK2-NP	X240	KK2	-	39
HY2-NP	X160	HY2	-	38	KK3-NP	X253	KK3	-	39
HY2-PH	HY2-P	HY2-P	-	46	KK4-NP	X267	KK4	-	39
HY4-NP	X187	HY4	-	38	KK5-NP	X269	KK5	-	39
HY5-NP	X196	HY5	HY5	38	KK7-N-PHT	-	-	-	52
HY6-NP	X216	HY6	-	38	KP1	1041Y	CG17	5CG4	6
HY12-NP	X232	HY12	-	38	KP2	SC1041R	-	-	6
HY12-PH	HY12-P	HY12-P	-	46	KP9	S1041JA	-	-	7
HY13-NP	X235	HY13	-	38	KW1+	1176	KW1	5KW1	12
HY13-PH	HY13-P	HY13-P	-	46	KW1+-NP	1176	KW1	5KW1	12
HY14-NP	X236	HY14	-	38	KW1-IMP	-	-	-	12
HY14-PH	HY14-P	HY14-P	-	46	KW1-JET	1176	KW1	5KW1	12
HY15-NP	-	-	-	38	KW1-JET-NP	1176	KW1	5KW1	12
HY15-PH	HY15-P	HY15-P	-	46	KW1-PHC	KW1-PC	-	-	12/22
HY16-NP	-	-	-	38	KW1-RH	1176-HA	-	-	58
HY16-PH	HY16-P	HY16-P	-	46	KW5	A1176	KW5	6KW1	12
HY17-NP	-	-	-	39	KW6	-	-	-	12
HY17-PH	-	-	-	46	KW9	A1176T	KW9	-	12
IL1	1041H	IL1	IS1	11	KW9-NP	A1176T	KW9	-	12
IL11-NP	1043J	IL11	-	11	KW9-RT-NP	1176RK	-	-	12
IL210	S1042Z/S1042ZP	-	-	11	KW10	A1176ST	KW10	KWT	12
					KW10-NP	A1176ST	KW10	KWT	12
					KW11	A1176KT	KW11	-	12

JET	ILCO	EZ	STAR	PAGE	JET	ILCO	EZ	STAR	PAGE
KW11-NP	A1176KT	KW11	-	12	MIT1-PH	MIT1-P	MIT1-P	-	44/47
L01ABM	L1001ABM	-	7CQ12	7	MIT3-NP	X224	MIT3	-	40
L01EH	L1001EH	-	7CQ11	7	MIT4-NP	X245	MIT4	-	31/40
L07KMA	N1007KMC	-	7SA3	16	MIT4-PH	MIT4-P	MIT4-P	-	44/47
L1	1004	L1	5LO1	12	MIT6-NP	X263	MIT6	-	40
L1-6-NS	A1011-L1	-	-	8/24	MIT6-PH	MIT6-P	MIT6-P	-	47
L2-6-NS	A1011-L2	-	-	8/24	MIT10-PHT	MIT8-PT	-	-	52
L3-6-NS	A1011-L3	-	-	8/24	MIT11-PHT	MIT9-PT	-	-	52
L4	1004A	L4	6LO1	12	MIT12-N-PHT	MIT8-EK	-	-	52
L4-6-NS	A1011-L4	RU101	-	8/24	MIT13-N-PHT	MIT9-EK	-	-	53
L5	1004AL	-	7LO1	12	MOS-1-NS	1091	-	-	27/29
L6M	A1015M	-	6CH2	6	MOS-2-NS	1323L	-	-	27/29
L6MR	A1015MR	-	6CH4	6	MOS-3-NS	1115	-	-	27/29
L7M	L1015M	-	7CH2	6	MOS-4-NS	884BR	-	-	27/29
L7MR	L1015MR	-	7CH4	6	MOS-5-NS	1323	-	-	27/29
L11D1	L1011D1	-	7RU7	15	MTL-06-NS	-	-	-	14/25
L11D41	L1011D41	-	7RU8	15	MZ9-NP	X26	MZ9	MZ1	39
L11P	1011PAA	-	7RU2	15	MZ13-NP	X131	MZ13	MZ13	39
L11PZ	-	-	7RU5	15	MZ13-PH	MZ13-P	MZ13-P	-	46
L12-6-NS	A1011-L12	-	-	8/24	MZ16-NP	X178	MZ16	-	39
L34-6-NS	A1011-L34	-	-	8/24	MZ17-NP	X188	MZ17	-	40
L37	1004KL	-	7IL2	13	MZ19-NP	X201	MZ19	-	40
L41-6-NS	A1011-L41	-	-	8/24	MZ19-PH	MZ19-P	MZ19-P	-	46
L54G	L1054G	FR2	-	10	MZ27-NP	X222	MZ27	-	40
L191A	VR91	VR2	5VR1	18	MZ27-PH	MZ27-P	MZ27-P	-	47
LEB-1-NS	LB1	-	-	27/28	MZ31-NP	X249	MZ31	-	40
LEB-2-NS	LB2	-	-	27/28	MZ34-N-PHT	-	-	-	52
LEB-3-NS	LB3	-	-	27/28	NA6	R1064E	NA25	5RO4N	14
LEB-4-NS	LB4	-	-	27/28	NA12	1069LA, LB	NA12	5AU2	14
LEB-6-NS	LB6	-	-	27/29	NA14	1069L	NA14	-	14
LEB-7-NS	LB7	-	-	27/29	NA24	1069LC	NA24	-	14
LO80-5	80	-	-	13	NH1	1177N	NH1	5NA1	14
LR191A	VR91R	VR91R	5VR2	18	O4KA	X1054KF	-	6IL2	13
LXP90-PH	LXP90-P	-	-	48	P54F-NP	P54F	-	5DO4	9
M1	1092	M1	MA1	13	P1555-NP	P1555	WR5	5WR2N	18
M1+	1092	M1	MA1	13	PA8-NP	X9, X88	73VB, PA8	VW4	42
M1-IMP	-	-	-	13	PR7	PR91C	-	-	15
M1R	-	-	-	10	PU1	1866-13	-	-	15
M1-RV	1092R	-	-	13	PZ1	PZ1	PZ1	-	15
M1-TG	1092TG	-	-	11	R52	A1, PHA1	-	-	15
M2	1092B	M2	4MA2	13	R52L	A2, PHA2	-	-	15
M3	1092VR	M3	-	13	R55	A3, 1551	-	-	10
M4	1092V	M4	5MA3	13	R59	TE1, TE4	-	-	18
M5	1092VM	M5	5MA4	13	RA3	S1970AM	RA3	OBR11	30
M10	1092N	M10	5MA5	13	RA3-NP	S1970AM	RA3	OBR11	30
M11	1092H	M11	5MA6	13	RA4	1970AM	RA4	HBR11	30
M12	1092D	M12	5MA7	13	RA4-NP	1970AM	RA4	HBR11	30
M13	1092DS	M13	4MA7	13	RN24-NP	X116	RN24	5RP3	41
M19	1092J	M14	6MA8	13	RN30-NP	X147	RN30	-	41
M27	1092NR	M16	-	13	RO1	1069W	-	RO1	15
M900	1092-900	M19	-	13	RU1	1011	RU1	5RU1	15
M6000	1092-6000	M20	M6000	13	RU4	1011P, N1011P	RU4, RU52	5RU2	15
M6000B	1092-6000B	M25	-	14	RU16	A1011P	RU16	6RU2	15
M7000	1092-7000	M21	M7000	13	RU18	1011PZ	-	5RU5	15
M7000B	1092-7000B	M26	-	14	RU18 1/2	A1011PZ	-	6RU5	15
MA3	MA3	-	-	14	RU19	1011D41	-	5RU8	15
MAZ24-N-PHT	MAZ24RT5	-	-	52	RU20	A1011D41	RU53	6RU8	15
MB16-NP	MB16	MB16	-	40	RU21	N1011M	RU7	5RU9	15
MB41-NP	X82	MB41	-	40	RU22	A1011M	-	6RU9	15
MD17	MD1054K	MD17	-	14	RU45	1011D1	RU45	5RU7	15
MIT1-NP	X176	MIT1	MI1	31/40	RU46	A1011D1	RU46	6RU7	15

JET	ILCO	EZ	STAR	PAGE	JET	ILCO	EZ	STAR	PAGE
S&G-1-NS	1063D	-	-	27/29	SUZ17-NP	X186	SUZ17	-	41
S&G-2-NS	1063B	-	-	27/29	SW1	1534	-	-	18
S&G-3-NS	1063E	-	-	27/29	T3	1141E	-	5TA2	18
S1	1009	S1	5SA2	16	T3NR	1550	-	-	6
S4	1010U	S4	5SA1	16	T7	1141GE	T7	5TA4	18
S6	N1007KMA	S6	6SA3	16	T10HF54-N-PHT	HU46T2	-	-	49
S7BW-PH	S7BW-P	-	-	48	T21	O1225N	-	-	20
S16	N1007KMB	S16	5SA3	16	T23	1270C	-	T23	20
S22 1/2-LA	1007LA	S22 1/2	5SA-LA	16	T26	1242L	-	T26	20
S22 LA	O1007LA	S22	6SA-LA	16	T32	PH32	-	-	15
S31	N1007RMA	S31	6SA6	16	T32-NP	PH32	-	-	15
S32	N1007RMB	S32	5SA6	16	T146	1270D	-	T146	20
S34YS-PH	S34YS-P	-	-	48	T146-TC	-	-	-	20
S48HF-PH	S48HF-P	-	-	48	TM100	1603	TM3	-	36
S50HF-PH	S50HF-P	-	-	48	TM110	1610	TM10	-	36
S54F	S54F	-	5DO2	9	TM130	1608	TM8	-	36
S66NN-PH	S66NN-P	-	-	48	TM150	1609	TM9	-	36
S68	1010N	S68	5SA7	16	TM180	1607	TM7	-	36
S69	L1010N	S69	6SA7	16	TM200	1604	TM4	-	36
SAA1-NP	X52	SAA1	-	41	TM300	1601	TM1	-	36
SC1	1145	SC1	5SH1	17	TM400	1602	TM2	-	36
SC1-DD	1145	SC1	5SH1	16	TM700	1606	TM6	-	36
SC1-PHC	SC1-PC	-	-	17/22	TR20-NP	T61C	T61C	TO1	42
SC1-RH	1145-HA	-	-	58	TR20-PH	T61C-P	T61C-P	-	47
SC4	1145A	SC4	6SH1	17	TR23-NP	T61F	T61F	LU1	36/42
SC4-RH	1145A-HA	-	-	58	TR25-NP	TR25	TR25	TO2	42
SC6	1307A	SC6	SH2	17	TR33-NP	X137	TR33	LTO1	42
SC7	1145F	SC7	5SH5	17	TR33-PH	TR33-P	TR33-P	-	47
SC8	1145E	SC8	5SH4	17	TR37-NP	X159	TR37	TO37	42
SC9	A1145E	SC9	6SH4	17	TR37-PH	-	-	-	47
SC9-RH	A1145E-HA	-	-	58	TR39-NP	X151	TR39	-	42
SC10	A1145F	SC10	6SH5	17	TR40-NP	X174	TR40	TO4	42
SC19	1145L	SC19	5SH3	17	TR40-PH	TR40-P	TR40-P	-	47
SC20	A1145L	SC20	6SH3	17	TR40-PHT	TOY57-PT	-	-	53
SC22	1307W	SC22	SH6	17	TR44-NP	X211	TR44	-	42
SC-LO	-	-	-	17	TR46-NP	X212	TR46	-	42
SE1+	1022	SE1	5SE1	17	TR47-NP	X217	TR47	TO47	42
SE1-JET	1022	SE1	5SE1	17	TR47-PH	TR47-P	TR47-P	-	48
SE1-M	-	-	5SE1M	18	TR47-PHT	TOY43AT4	-	-	53
SE1-NP	1022	SE1	5SE1	17	TR47-PHT-LC	-	-	-	53
SE8	1022AB	-	6SE1	17	TR47-N-PHT	TOY43-EK	-	-	53
SEC-1-NS	-	-	-	27/28	TR48/49-B	-	-	-	52
SEC-2-NS	-	-	-	27/28	TR48-PHT	TOY48BT4	-	-	52
SK1	R1001EN	SK1	5CO5	7	TR48-PHT-LC	-	-	-	52
SK4	R1001EL	-	7CO5	7	TR48-N-PHT	TOY48-EK	-	-	52
SKY-5-NS	1517	-	5ME2	14/25	TR49-PHT	TOY40BT4	-	-	52
SKY-6-NS	A1517	-	6ME2	14/25	TR49-PHT-LC	-	-	-	52
SL1	1120D	SL1	SL1	18	TR49-N-PHT	TOY40-EK	-	-	52
SR1-NP	X6	62DT	DA4	41	TR51-N-PHT	-	-	-	53
SR8-NP	X251	SUB1	-	41	TR53-NP	X223	TR53	-	42
SR8-PH	SUB1-P	SUB1-P	-	47					
SR8-N-PHT	-	-	-	53					
SUZ11-NP	X87	SUZ11	-	41					

JET	ILCO	EZ	STAR	PAGE	JET	ILCO	EZ	STAR	PAGE
TR60-N-PHT	-	-	-	52	Y103	O1122B	Y103	YJ4	20
V26K-NP	VW67	VW67	VW2	42	Y149	S1770U	Y149	OPL68	31
V28M-NP	VW71	VW71	VW3	42	Y149-NP	S1770U	Y149	OPL68	31
V29R-NP	VW71A	VW71A	VW5	42	Y151-NS	-	-	OPL70	31
V30-NP	X9	73VB	VW4	42	Y152	P1770U	Y152	HPL68	31
V30-PH	73VB-P	73VB-P	-	48	Y152-NP	P1770U	Y152	HPL68	31
V37-NP	X203	V37	-	43	Y153	P1786	Y153	HPL73	31
V37-PH	V37-P	V37-P	-	48	Y153-NP	P1786	Y153	HPL73	31
VL4-NP	X30	VO73S	-	43	Y153-PH	Y153-P	Y153-P	-	44
VL6-NP	X80	VL6	-	43	Y154	P1789	Y154	HPL89	31
VL8-NP	X140	VL8	-	43	Y154-NP	P1789	Y154	HPL89	31
WB1A	1071	W1	5W11	18	Y154-PH	Y154-P	Y154-P	-	44
WB1B	1071BD	-	-	18	Y155	P1793	Y155	CHR93	31
WB1C	1071BE	-	-	18	Y155-NP	P1793	Y155	CHR93	31
WB2A	1071A	-	-	18	Y155-PH	Y155-P	Y155-P	-	44
WB2B	1071D	-	-	18	Y155V-NP	1793V	-	-	32
WB2C	1071E	-	-	18	Y157	P1794	Y157	CHR94	32
WE1	1123	WE1	5WE1	18	Y157-NP	P1794	Y157	CHR94	32
WK2	1175N	WK2	5WK1	18	Y157-PH	Y157-P	Y157-P	-	44
WR3	1054WB	WR3	5WR2	18	Y157V-NP	1794V	-	-	32
WR3-NP	1054WB	WR3	5WR2	18	Y159	P1795	Y159	-	32
WR3-RH	1054WB-HA	-	-	58	Y159-NP	P1795	Y159	-	32
WR5	N1054WB	WR5	5WR2N	18	Y159-PH	Y159-P	Y159-P	-	44
WR5-NP	N1054WB	WR5	5WR2N	18	Y159V-NP	-	-	-	32
WR5-PHC	WR5-PC	-	-	18/22	Y160-PHT	Y160-PT	-	-	49
WR6	A1054WB	WR4	6WR2	18	Y160-PHT-LC	-	-	-	49
XL7	1180S	XL7	-	19	Y160-N-PHT	Y160-EK	-	-	49
Y1+	999	Y1	5YA1	19	Y165-PHT	Y164-PT	-	-	49
Y1E	999N	Y1E	5YA1E	19	Y220	999B	Y220	4YA1	19
Y1K-NP	999K1	Y221	-	19	Y221	SX9B	-	-	20
Y1M	999	-	5YA1M	19	Y227	998GST	-	6YA8	20
Y1R	999R	-	5YA13	19	Y-LO	-	-	-	19
Y2	999A	Y2	6YA1	19	YAL-1-NS	885BL	-	-	27/29
Y2E	999A	-	-	19	YAL-2-NS	1095	-	-	27/29
Y2K-NP	999K3	Y223	-	19	YAL-3-NS	1095HL	-	-	27/29
Y4	998	Y4	6YA3	19	YH38-NP	X77	YH38	-	43
Y5	997EB	Y5	-	19	YH46-NP	X120	YH46	-	43
Y6	997X	Y6	4YA6	19	YH47-NP	X119	YH47	-	43
Y6E	997X	-	-	19	YH48/50-NP	X117	YH48/50	-	43
Y11	O1122	Y11	YJ3	20/30/36	YH49/51-NP	X118	YH49/51	-	43
Y12	O1122A	Y12	YJ1	20	YOR-1-NS	1028AY	-	-	27/29
Y12G	O1122A	-	-	20/30/36	YOR-2-NS	1028D	-	-	27/29
Y12G-NP	O1122A	-	-	30	YU1-NP	X153	YU1	-	43
Y13	O1122R	Y13	YJ5	20	YU2-NP	X167	YU2	-	43
Y14	O1122AR	Y14	YJ2	20					
Y52	997D, E	Y52	5YA6	19					
Y52E	997D, E	-	-	19					
Y54	O997E	Y54	6YA6	19					
Y54E	O997E	-	-	19					
Y78	998GA	Y78	6YA12	19					

MANUFACTURER	JET	DITTO	PAGE	MANUFACTURER	JET	DITTO	PAGE
ABUS 85/30 LEFT PADLOCK 4 PIN	AB2	+	4	BEST 1A1J1	1A1J1-NS		5/24
ABUS 85/30 RIGHT PADLOCK 4 PIN	AB1	+	4	BEST 1A1J1B	1A1J1B-NS		5/24
ABUS 85/40 LEFT PADLOCK 5 PIN	AB3		4	BEST 1A1JK1 (COMPOSITE)	1A1JK1-NS		5/23
ABUS 85/40 RIGHT PADLOCK 5 PIN	AB4		4	BEST 1A1K1	1A1K1-NS		5/24
ACE TUBULAR BRASS	137B		4/20/36	BEST 1A1K1B	1A1K1B-NS		5/24
ACE TUBULAR STEEL	137S		4/20/36	BEST 1A1L1	1A1L1-NS		5/24
ACURA INTEGRA 1986-89, LEGEND 1986-92	HD84.92-NP		37	BEST 1A1L1B	1A1L1B-NS		5/24
ACURA INTEGRA 1990-93, VIGOR 1992-94	HD96-NP		37	BEST 1A1M1	1A1M1-NS		5/24
AMERICAN JUNKUNC BKB	AM1	+	4	BEST 1A1M1B	1A1M1B-NS		5/24
AMERICAN JUNKUNC PTKB-1 5 PIN	AM3	+	4	BEST 1A1N1	1A1N1-NS		5/24
AMERICAN JUNKUNC PTKB-1 5 PIN NEW BOW	AM6	+	4	BEST 1A1N1B	1A1N1B-NS		5/24
AMERICAN JUNKUNC PTKB-2 6 PIN NEW BOW	AM7	+	4	BEST 1A1O1	1A1O1-NS		5/24
AMERICAN MOTORS IGNITION 1970-87	RA4		30	BEST 1A1O1B	1A1O1B-NS		5/24
AMERICAN MOTORS IGNITION 1970-87	RA4-NP	+	30	BEST 1A1R1	1A1R1-NS		5/24
AMERICAN MOTORS DOOR & TRUNK 1970-87	RA3		30	BEST 1A1R1B	1A1R1B-NS		5/24
AMERICAN MOTORS DOOR & TRUNK 1970-87	RA3-NP	+	30	BEST 1A1TB1	1A1TB1-NS		5/24
ARROW 6 PIN MASTER	AR-ER		4	BEST 1A1TB1B	1A1TB1B-NS		5/24
ARROW K11-1C INTERCHANGEABLE CORE	AR-1C-NS	+	4/23	BEST 1A1TD1	1A1TD1-NS		5/24
ARROW K11-1D INTERCHANGEABLE CORE	AR-1D-NS	+	4/23	BEST 1A1TE1	1A1TE1-NS		5/24
ARROW K2 5 PIN	AR1	+	4	BMW 1600, 2002 1968-76 IGNITION/DOOR	BMW1-NP		37
ARROW K6A 6 PIN	AR3	+	4	BMW 5-, 7- SERIES 1985-87, 6-SERIES 1985-89, 3- SERIES 1985-91	BMW3-NP		37
ARROW K6A 6 PIN NS	K6-NS		4/23	BMW 5-, 7- SERIES 1985-87, 6-SERIES 1985-89, BMW3-PH			44
ARROW K7 6 PIN NS	K7-NS		4/23	BMW 5-, 7- SERIES 1988-94, 8-SERIES 1991-94, 3- SERIES 1992-94 PLASTIC BOW	S7BW-PH		48
ARROW K7 6 PIN, I.G. HEAD	AR4	+	4	BOMMER (HUDSON)	HL2	+	6
ARROW K7 HOTEL BOW	AR4-RH		58	BRIGGS & STRATTON	Y12G	+	30
AUDI, VW, SEAT, SKODA - VARIOUS EUROPEAN MARKET MODELS ONLY TRANSPONDER KEY	HU66VW-N-PHT		49	BRIGGS & STRATTON	Y12G-NP		30
AUDI A8/S8 2001-03, A6/S6/RS6, ALLROAD, TT 2001 ON, A4/S4 2002 ON TRANSPONDER KEY	HU67-PHT		53	BRIGGS & STRATTON 75101, 322727	GAS		30
AUDI / VW HU67-PHT LESS CHIP	HU67-PHT-LC		53	BRIGGS & STRATTON 75101, 322727	GAS-NP	+	30
AUDI / VW TRYOUT KEY (BLADE ONLY)	HU66VW-B		53	BRIGGS & STRATTON 75101, 322727	B1		30
AUTH. 46X, FLORENCE, HUDSON	HL1	+	10	BRIGGS & STRATTON 75101, 322727	B1-NP	+	30
AUTO UTILITY KEY FOR GAS CAPS, ETC.	AUT1-NP		30	BRIGGS & STRATTON 75102, 322727	B2		30
BALDWIN 5 PIN W/SC1 KEYWAY	BAL-1-NS		4/23	BRIGGS & STRATTON 75102, 322727	B2-NP	+	30
BARGMAN 5 PIN	BN1-NP		5	BRIGGS & STRATTON 320734	B5		30
BAUER FILE CABINET	BAU1		5	BRIGGS & STRATTON 320734	B5-NP	+	30
BELL MFG. (FOR MAIL BOXES ETC.)	BL1-NP		5	BRIGGS & STRATTON 320842	B52		30
BEST 1A1A1	BE2	+	5	BRIGGS & STRATTON 320842	B52-NP	+	30
BEST 1A1A1	1A1A1-NS		5/24	BRIGGS & STRATTON 321106	B4		30
BEST 1A1A1B	1A1A1B-NS		5/24	BRIGGS & STRATTON 321106	B4-NP	+	30
BEST 1A1B1	1A1B1-NS		5/24	CAPRI (MERCURY) 1975-78	FC7-NP		37
BEST 1A1B1B	1A1B1B-NS		5/24	CCL 6905 5 PIN	CCL1-NP		6
BEST 1A1BA1	1A1BA1-NS		5/23	CCL 8618C-CR 5 PIN	CO10	+	6
BEST 1A1C1	1A1C1-NS		5/24	CCL 8687C-CR 6 PIN	CO17	+	6
BEST 1A1C1B	1A1C1B-NS		5/24	CCL 8688C-CL 7 PIN	CO54 1/2	+	6
BEST 1A1D1	1A1D1-NS		5/24	CCL 8688C-CR 7 PIN	CO19	+	6
BEST 1A1D1B	1A1D1B-NS		5/24	CEMEX (ALBA E42DN)	E42DN		6
BEST 1A1DD1	1A1DD1-NS		5/24	CEMEX (ALBA T3NR)	T3NR		6
BEST 1A1DD1B	1A1DD1B-NS		5/24	CESSNA AIRCRAFT	ES8		30
BEST 1A1DE1 (COMPOSITE)	1A1DE1-NS		5/23	CESSNA AIRCRAFT	Y11		30
BEST 1A1E1	1A1E1-NS		5/24	CESSNA AIRCRAFT	Y12		30
BEST 1A1E1B	1A1E1B-NS		5/24	CHANTRELL-LOCKWOOD B317M MASTER 6 PIN	L6M	+	6
BEST 1A1F1	1A1F1-NS		5/24	CHANTRELL-LOCKWOOD B318M REVERSE MASTER 6 PIN	L6MR	+	6
BEST 1A1F1B	1A1F1B-NS		5/24	CHANTRELL-LOCKWOOD MASTER 7 PIN	L7M	+	6
BEST 1A1G1	1A1G1-NS		5/24	CHANTRELL-LOCKWOOD REVERSE MASTER 7 PIN	L7MR	+	6
BEST 1A1G1B	1A1G1B-NS		5/24	CHICAGO K4	CG1	+	6
BEST 1A1H1	1A1H1-NS		5/24	CHICAGO K4L	CG2	+	6
BEST 1A1H1B	1A1H1B-NS		5/24	CHICAGO K4R	CG4	+	6
				CHICAGO K5 5 PIN	CG16	+	6

MANUFACTURER	JET	DITTO	PAGE	MANUFACTURER	JET	DITTO	PAGE
CHICAGO K35	CG22	+	6	CLUB ANTI-THEFT STEERING LOCK SERIES B	CB2-NP		31
CHICAGO K100M MASTER	K100M	+	6	CLUB ANTI-THEFT STEERING LOCK SERIES C	CB3-NP		31
CHICAGO K101	K101	+	6	CLUB ANTI-THEFT STEERING LOCK SERIES D	CB4-NP		31
CHICAGO K101H WITH SECURITY DIMPLE	K101H-NP	+	6	CLUB ANTI-THEFT STEERING LOCK SERIES E	CB5-NP		31
CHICAGO K102	K102	+	6	CLUB ANTI-THEFT STEERING LOCK SERIES F	CB6-NP		31
CHICAGO K102H WITH SECURITY DIMPLE	K102H-NP	+	6	CLUB ANTI-THEFT STEERING LOCK SERIES G	CB7-NP		31
CHICAGO K103	K103	+	6	CLUB ANTI-THEFT STEERING LOCK SERIES H	CB8-NP		31
CHICAGO K103H WITH SECURITY DIMPLE	K103H-NP	+	6	CLUB ANTI-THEFT STEERING LOCK SERIES R/H	CB9-NP		31
CHICAGO K104	K104	+	6	CLUB ANTI-THEFT STEERING LOCK SERIES L/H	CB10-NP		31
CHICAGO K104H WITH SECURITY DIMPLE	K104H-NP	+	6	CLUB ANTI-THEFT STEERING LOCK NEW CHINA - A	CB11-NP		31
CHICAGO KP1	KP1	+	6	CLUB ANTI-THEFT STEERING LOCK NEW CHINA - C	CB12-NP		31
CHICAGO KP2 4 PIN	KP2	+	6	CLUB ANTI-THEFT STEERING LOCK NEW CHINA - F	CB13-NP		31
CHICAGO KP9 4 PIN	KP9	+	7	CLUB ANTI-THEFT STEERING LOCK NEW CHINA - E	CB14-NP		31
CHICAGO, FORT TUBULAR BRASS	137B		4/20/36	CLUB ANTI-THEFT STEERING LOCK NEW CHINA - D	CB15-NP		31
CHICAGO, FORT TUBULAR STEEL	137S		4/20/36	CLUB ANTI-THEFT STEERING LOCK NEW CHINA - J	CB16-NP		31
CHRYSLER 1968-85 IGNITION & DOOR	Y152		31	CLUB ANTI-THEFT STEERING LOCK NEW CHINA - K	CB17-NP		31
CHRYSLER 1968-85 IGNITION & DOOR	Y152-NP	+	31	CORBIN 5865JVR 5 PIN	CO68	+	7
CHRYSLER 1968-89 TRUNK	Y149		31	CORBIN 8658JVR 6 PIN	CO26		7
CHRYSLER 1968-89 TRUNK	Y149-NP	+	31	CORBIN GR. M. Z1-059AB-5	CO90	+	7
CHRYSLER 1986-90 IGNITION & DOOR	Y153		31	CORBIN GR. M. Z1-059AB-6	CO89	+	7
CHRYSLER 1986-90 IGNITION & DOOR	Y153-NP	+	31	CORBIN GR. M. Z1-059AB-7	L01ABM		7
CHRYSLER 1986-90 IGNITION & DOOR PLASTIC BOW	Y153-PH		44	CORBIN K1-80-5	CO97	+	7
CHRYSLER 1990-92	Y154		31	CORBIN LOCKOUT KEY 059AD-6 (MASTER FOR 59A1, A2, B1, B2, C1, C2, D1 & D2 KEYWAYS)	CO-LO		8
CHRYSLER 1990-92	Y154-NP	+	31	CORBIN MSTR 57AD 6 PIN	057AD-6-NP	+	8
CHRYSLER 1990-92 PLASTIC BOW	Y154-PH		44	CORBIN MSTR 59AD 6 PIN	059AD-6		8
CHRYSLER 1993	Y155		31	CORBIN MSTR 59AD 7 PIN	059AD-7		8
CHRYSLER 1993	Y155-NP	+	31	CORBIN X1-27-5	CO3	+	7
CHRYSLER 1993 PLASTIC BOW	Y155-PH		44	CORBIN X1-27-6	CO4	+	7
CHRYSLER 1993 VALET KEY	Y155V-NP	+	32	CORBIN X1-27-7	CO33	+	7
CHRYSLER 1994	Y157		32	CORBIN X1-67-5	CO7	+	7
CHRYSLER 1994	Y157-NP	+	32	CORBIN X1-67-6	CO36	+	7
CHRYSLER 1994 PLASTIC BOW	Y157-PH		44	CORBIN X1-67-7	CO37	+	7
CHRYSLER 1994 VALET KEY	Y157V-NP		32	CORBIN X1-77-5	SK1	+	7
CHRYSLER 1996	Y159		32	CORBIN X1-77-6	CO62	+	7
CHRYSLER 1996	Y159-NP	+	32	CORBIN X1-77-7	SK4	+	7
CHRYSLER 1996 PLASTIC BOW	Y159-PH		44	CORBIN X1-97-5	CO5	+	7
CHRYSLER 1996 VALET KEY	Y159V-NP		32	CORBIN X1-97-6	CO6	+	7
CHRYSLER CONCORDE, DODGE INTREPID 1998, LHS, 300M 1999 TRANSPONDER KEY	Y160-PHT		49	CORBIN X1-99-5	CO1	+	7
CHRYSLER CONCORDE, DODGE INTREPID 1998, LHS, 300M 1999 TRANSPONDER KEY FOR SMART CLONE W/CRYPTO SW	Y160-N-PHT		49	CORBIN X1-99-6	CO2	+	7
CHRYSLER PACIFICA, TOWN & COUNTRY, DODGE CARAVAN 2004 ON TRANSPONDER KEY	Y165-PHT		49	CORBIN Z1-59A1-6	CO91	+	7
CHRYSLER Y160-PHT LESS CHIP	Y160-PHT-LC		49	CORBIN Z1-59A2-6	CO92	+	7
CHRYSLER DODGE / PLYMOUTH COLT, PLYMOUTH CHAMP 1971-84	DC2-NP		31	CORBIN Z1-59B1-6	CO94	+	7
CHRYSLER DODGE / PLYMOUTH COLT 1985-88, CONQUEST 1984-89, DODGE RAIDER 1987-90	DC3-NP		31	CORBIN Z1-59B2-6	CO95	+	7
CHRYSLER EAGLE TALON, PLYMOUTH LASER 1990	MIT1-NP		31	CORBIN Z1-59C1-6	CO98	+	7
CHRYSLER EAGLE TALON, PLYMOUTH LASER 1990 PLASTIC BOW	MIT1-PH		44	CORBIN Z1-59C2-6	CO99	+	7
CHRYSLER SEBRING COUPE, DODGE AVENGER 1996-00	MIT4-NP		31	CORBIN Z1-59D1-6	CO51	+	7
CHRYSLER SEBRING COUPE, DODGE AVENGER 1996-00 PLASTIC BOW	MIT4-PH		44	CORBIN Z1-59D2-6	CO52	+	7
CHRYSLER MASTER TRYOUT KEY FOR LOCKSMITH USE ONLY	Y151-NS		31	CORBIN Z1-60-5	CO87	+	7
CLINTON 123	CL1		7	CORBIN Z1-60-6	CO88	+	7
CLOPAY GARAGE DOOR 4 PIN	CLP1-NP		7	CORBIN Z1-60-7	L01EH		7
CLUB ANTI-THEFT STEERING LOCK SERIES A	CB1-NP		31	CORBIN RUSSWIN 57A1-6 PIN	57A1-6-NS		9/24
				CORBIN RUSSWIN 57A2-6 PIN	57A2-6-NS		9/24
				CORBIN RUSSWIN 57B1-6 PIN	57B1-6-NS		9/24
				CORBIN RUSSWIN 57B2-6 PIN	57B2-6-NS		9/24
				CORBIN RUSSWIN 59A1-6 PIN	59A1-6-NS		9/24
				CORBIN RUSSWIN 59A1-6 PIN	CR91		8
				CORBIN RUSSWIN 59A2-6 PIN	59A2-6-NS		9/24
				CORBIN RUSSWIN 59B1-6 PIN	59B1-6-NS		9/24

MANUFACTURER	JET	DITTO	PAGE	MANUFACTURER	JET	DITTO	PAGE
CORBIN RUSSWIN 59B2-6 PIN	59B2-6-NS		9/24	DIEBOLD SAFE DEPOSIT	DIE-3-NS		26/28
CORBIN RUSSWIN 59C1-6 PIN	59C1-6-NS		9/24	DOMINION 6 PIN	DO6-NP		9
CORBIN RUSSWIN 59C2-6 PIN	59C2-6-NS		9/24	DOMINION, CANADA POST 6 PIN	P54F-NP		9
CORBIN RUSSWIN 59D1-6 PIN	59D1-6-NS		9/24	DOMINION S54F 5 PIN	S54F		9
CORBIN RUSSWIN 59D2-6 PIN	59D2-6-NS		9/24	EAGLE .050" X .265"	T146		20
CORBIN RUSSWIN 60-5 PIN	CR87		8	EAGLE 11929, HARLOC 700, LORI L100 (3100-00-4005) 5 PIN	EA27	+	9
CORBIN RUSSWIN 60-6 PIN	CR88		8	EAGLE 0754 (LORI L400)	EA47	+	9
CORBIN RUSSWIN 60-6 PIN	60-6-NS		9/24	EAGLE FLAT STEEL KEY WITH THROAT CUT	T146-TC		20
CORBIN RUSSWIN 77-6 PIN	77-6-NS		8/24	ESP ES1 5 PIN	ES1	+	9
CORBIN RUSSWIN D1-5 PIN	CR45		8	ESP ES8 - 5 DISC.	ES8	+	9
CORBIN RUSSWIN D1-6 PIN	CR46		8	ESP ES8M MASTER - 5 DISC.	ES8M	+	9
CORBIN RUSSWIN D1-6 PIN	D1-6-NS		8/24	ESP ES9 5 PIN	ES9	+	9
CORBIN RUSSWIN D2-6 PIN	D2-6-NS		8/24	FALCON 5 PIN P1573E	FA1	+	10
CORBIN RUSSWIN D3-6 PIN	D3-6-NS		8/24	FALCON 6 PIN P1577E	FA2	+	10
CORBIN RUSSWIN D4-6 PIN	D4-6-NS		8/24	FALCON KB1577G 6 PIN	FA3	+	10
CORBIN RUSSWIN H1-6 PIN	H1-6-NS		8/24	FALCON KB577E	KB577E-NS		10/25
CORBIN RUSSWIN H2-6 PIN	H2-6-NS		8/24	FALCON KB577E	KB577E-NS		10/25
CORBIN RUSSWIN H3-6 PIN	H3-6-NS		8/24	FALCON KB577G	KB577G-NS		10/25
CORBIN RUSSWIN H4-6 PIN	H4-6-NS		8/24	FALCON KB577J	KB577J-NS		10/25
CORBIN RUSSWIN H5-6 PIN	H5-6-NS		8/24	FANAL (ALBA- R55)	R55		10
CORBIN RUSSWIN H6-6 PIN	H6-6-NS		8/24	FERUM 50MM PADLOCKS	M1R		10
CORBIN RUSSWIN H7-6 PIN	H7-6-NS		8/24	FIAT, ALFA ROMEO IGNITION	FT36-NP		37
CORBIN RUSSWIN H8-6 PIN	H8-6-NS		8/24	FIAT, ALFA ROMEO, FERRARI IGNITION	FT46-NP		37
CORBIN RUSSWIN L1-6 PIN	L1-6-NS		8/24	FIAT 1967-83, PANTERA, FERRARI DOOR / TRUNK	FT38-NP		37
CORBIN RUSSWIN L2-6 PIN	L2-6-NS		8/24	FIAT 1967-83, PANTERA, FERRARI DOOR / TRUNK	FT37-NP		37
CORBIN RUSSWIN L3-6 PIN	L3-6-NS		8/24	FIAT 1967-83, PANTERA, FERRARI DOOR / TRUNK	FT37-NP		37
CORBIN RUSSWIN L4-5 PIN	CR-L4-5		8	FLAT STEEL (MISC.)	T21	+	20
CORBIN RUSSWIN L4-6 PIN	CR-L4-6		8	FLAT STEEL (MISC.)	T23	+	20
CORBIN RUSSWIN L4-6 PIN	L4-6-NS		8/24	FLAT STEEL (MISC.)	T26	+	20
CORBIN RUSSWIN L12-6 PIN	L12-6-NS		8/24	FORD ADAPTER	FOA-1		33
CORBIN RUSSWIN L34-6 PIN	L34-6-NS		8/24	FORD 1967-84 IGNITION	H51		32
CORBIN RUSSWIN L41-6 PIN	CR-L41-6		8	FORD 1967-84 IGNITION	H51-NP	+	32
CORBIN RUSSWIN L41-6 PIN	L41-6-NS		8/24	FORD 1967-96 TRUNK	H50		32
DAEWOO LANOS 1999-02	DW47R-PH		44	FORD 1967-96 TRUNK	H50-NP	+	32
DAEWOO LANOS TRANSPONDER 1999-02	DW47R-N-PHT		49	FORD 1984 1/2 ON IGNITION	H54		32
DAEWOO LEGANZA 1999-02, SUZUKI VERONA 2004-06	DW47-PH		44	FORD 1984 1/2 ON IGNITION	H54-NP	+	32
DAEWOO LEGANZA TRANSPONDER 1999-02	DW47-N-PHT		49	FORD 1990 ON IGNITION	H60		32
DAEWOO NUBIRA 1999-02, CHEVY AVEO, SUZUKI FORENZA 2004 ON	DW48R-PH		44	FORD 1990 ON IGNITION	H60-NP	+	32
DAEWOO NUBIRA 1999-02 TRANSPONDER KEY	DW48R-N-PHT		49	FORD 1993 ON IGNITION	H67		33
DATSUN, NISSAN 1974-81	DA21-NP		40	FORD 1993 ON IGNITION	H67-NP		33
DATSUN, NISSAN 1974-81 PLASTIC BOW	DA21-PH		47	FORD 1993 ON IGNITION PLASTIC BOW	H67-PH		45
DATSUN, NISSAN 1974-81	DA22-NP		40	FORD 1996 ON 8 CUT	H75		33
DATSUN, NISSAN 1977-81 810, MAXIMA, 1979-83 280ZX	DA23-NP		40	FORD 1996 ON 8 CUT	H75-NP		33
DATSUN, NISSAN 1977-81 810, MAXIMA, 1979-83 280ZX	DA24-NP		40	FORD 1996 ON 8 CUT PLASTIC BOW	H75-PH		45
DATSUN, NISSAN 1982-90	DA25-NP		41	FORD AEROSTAR 1986-1990	H55		32
DATSUN, NISSAN 1982-90 PLASTIC BOW	DA25-PH		47	FORD AEROSTAR 1986-1990	H55-NP		32
DATSUN, NISSAN 1991-96	DA31-NP		41	FORD ASPIRE 1994-97	H70-NP		33
DATSUN, NISSAN 1991-96 PLASTIC BOW	DA31-PH		47	FORD CONTOUR, MERCURY MYSTIQUE 1995-96	H71		33
DATSUN, NISSAN VALET KEY FOR DA25 & DA31 1982-96	DA28-NP		41	FORD CONTOUR, MERCURY MYSTIQUE 1995-96	H71-NP		33
DEXTER 62 6 PIN	DE8	+	9	FORD CONTOUR, MERCURY MYSTIQUE 1996-2000	H78		33
DEXTER 67 5 PIN	DE6	+	9	FORD CONTOUR, MERCURY MYSTIQUE 1996-2000	H78-NP		33
DEXTER LOCKOUT KEY DE6 (ALSO FOR ARROW, KWIKSET & SEGAL)	DE-LO		9	FORD ESCORT, MERCURY TRACER 1991-1996	H62-NP		32
DIEBOLD SAFE DEPOSIT	DIE-1-NS		26/28	FORD ESCORT, MERCURY TRACER 1991-96	H62-PH		45
DIEBOLD SAFE DEPOSIT	DIE-2-NS		26/28	FORD ESCORT, MERCURY TRACER 1997-03	H76		33
				FORD ESCORT, MERCURY TRACER 1997-03	H76-NP		33
				FORD ESCORT, MERCURY TRACER 1997-03	H76-PH		45
				PLASTIC BOW			

MANUFACTURER	JET	DITTO	PAGE	MANUFACTURER	JET	DITTO	PAGE
FORD FESTIVA 1988-'93, PROBE 1988-'92, MERCURY TRACER 1988-'90, CAPRI 1991-'94	H59-NP		32	G.M. TRUNK "K" PLASTIC BOW	B47-PH		45
FORD MERCURY CAPRI PRE-1979, MERKUR XR4TI 1985-89	FC7-NP		32	G.M. MASTER KEY FOR LOCKSMITH USE ONLY	B15-NS		33
FORD MERCURY 1993 - MID 1996	H66-NP		33	G.M. BUICK RIVIERA, OLDS AURORA 1995-99, BUICK CENTURY, REGAL 1997-05 DOOR & TRUNK	B85-NP		35
FORD PROBE 1993-97	H65		32	G.M. CADILLAC ALLANTE 1987-88 IGNITION	B62		34
FORD PROBE 1993-97	H65-NP	+	32	G.M. CADILLAC ALLANTE 1987-88 IGNITION	B62-NP		34
FORD PROBE 1993-97 PLASTIC BOW	H65-PH		45	G.M. CADILLAC ALLANTE 1987-93 DOOR, TRUNK, GLOVE COMPARTMENT	B59-NP		34
FORD TAURUS, MERCURY SABLE 1986-89	H56-NP		32	G.M. CHEVY BERETTA, CORSICA 1988-90 IGNITION	B63-NP		34
FORD TAURUS, MERCURY SABLE 1986-89	H56-PH		44	G.M. CHEVY BERETTA, CORSICA 1991-96 IGNITION	B77-NP		35
FORD EARLY 1996 MUSTANG GT, COBRA, 1998-00 CONTOUR, MERCURY MYSTIQUE V6, 1999-02 MERCURY COUGAR 10 CUT W/TRANSPONDER	H73-PHT		50	G.M. CHEVY CAVALIER, PONTIAC SUNBIRD 1991-92, GR. AM, OLDS ACHIEVA, BUICK SKYLARK 1992 IGNITION	B68-NP		34
FORD 1996 TAURUS LX, SHO, MERCURY SABLE LS 8 CUT W/TRANSPONDER	H72-PHT		49	G.M. CHEVY CAVALIER, PONTIAC SUNBIRD 1993-94, GR. AM, OLDS ACHIEVA, BUICK SKYLARK 1993 IGNITION	B84-NP		35
FORD 1996 8 CUT TRANSLUCENT W/TRANSPONDER	H72-PHT-T		50	G.M. CHEVY CAVALIER, PONTIAC SUNFIRE 1995-05, GR. AM, OLDS ACHIEVA, BUICK SKYLARK 1996-98	B89		35
FORD 1996 TAURUS LX, SHO, MERCURY SABLE LS 8 CUT W/TRANSPONDER FOR SMART CLONE	H72-N-PHT		50	G.M. CHEVY CAVALIER, PONTIAC SUNFIRE 1995-05, GR. AM, OLDS ACHIEVA, BUICK SKYLARK 1996-98	B89-NP		35
FORD FOCUS 2000-05, ESCAPE, MAZDA TRIBUTE 2001-04 TRANSPONDER KEY	H86-PHT		50	G.M. CHEVY CAVALIER, PONTIAC SUNFIRE 1995-05, GR. AM, OLDS ACHIEVA, BUICK SKYLARK 1996-98 PLASTIC BOW	B89-PH		45
FORD LINCOLN LS 2000-02, THUNDERBIRD 2002	H74-PHT		50	G.M. CHEVY COBALT 2005	B109-NP		36
FORD TAURUS, MERCURY SABLE 2000 ON, EXPEDITION, LINCOLN NAVIGATOR 2003 ON, MUSTANG 2005 ON TRANSPONDER KEY	H84-PHT		50	G.M. CHEVY COLORADO 2004 ON, GMC CANYON 2004 ON	B108-NP		36
FORD TAURUS, FOCUS, MERCURY SABLE, LINCOLN LS 2000 ON TRANSPONDER KEY FOR SMART CLONE W/CRYPTO SW	H90-N-PHT		50	G.M. CHEVY COLORADO 2004 ON, GMC CANYON 2004 ON PLASTIC BOW	B108-PH		46
FORD H72-PHT LESS CHIP	H72-PHT-LC		50	G.M. CHEVY LUMINA 1990, PONTIAC GR. PRIX, OLDS CUTLASS SUPREME, BUICK REGAL 1988-90 DOOR & TRUNK	B64-NP		34
FORT LOCK K54G 5 PIN	54G		10	G.M. CHEVY LUMINA 1990, PONTIAC GR. PRIX, OLDS CUTLASS SUPREME, BUICK REGAL 1988-90 DOOR & TRUNK	B67-NP		34
FORT LOCK K154G 6 PIN	L54G		10	G.M. CHEVY LUMINA 1991-94, PONTIAC GR. PRIX, OLDS CUTLASS SUPREME, BUICK REGAL 1991-93 IGNITION	B78-NP		35
FRATELLI FACCHINETTI 0.6	FF1-NP		10	G.M. CHEVY LUMINA 1991-01, MONTE CARLO 1995-99, PONTIAC GR. PRIX, BUICK REGAL 1991-96, OLDS CUTLASS SUPREME 1991-97 DR. & TRK	B79-NP		35
GLOBE PADLOCK (FROM CHINA)	CO2L		10	G.M. CHEVY LUMINA 1991-01, MONTE CARLO 1995-99, PONTIAC GR. PRIX, BUICK REGAL 1991-96, OLDS CUTLASS SUPREME 1991-97 DR. & TRK	B79-NP		35
G.M. IGNITION & DOOR 1935-66	B10		33	G.M. CHEVY LUV 1972-80	TR23-NP		36
G.M. IGNITION & DOOR 1935-66	B10-NP		33	G.M. CHEVY MALIBU 1997-03, OLDS CUTLASS 1997-99, CHEVY IMPALA 2000-05	B91		35
G.M. TRUNK 1935-66	B11		33	G.M. CHEVY MALIBU 1997-03, OLDS CUTLASS 1997-99, CHEVY IMPALA 2000-05	B91-NP		35
G.M. TRUNK 1935-66	B11-NP		33	G.M. CHEVY MALIBU 1997-03, OLDS CUTLASS 1997-99, CHEVY IMPALA 2000-05	B91-NP		35
G.M. IGNITION & DOOR "A"	B48		33	G.M. CHEVY MALIBU 1997-03, OLDS CUTLASS 1997-99, CHEVY IMPALA 2000-05 PLASTIC BOW	B91-PH		45
G.M. IGNITION & DOOR "A"	B48-NP	+	33	G.M. CHEVY NOVA 1986-88 IGNITION	B55-NP		34
G.M. IGNITION & DOOR "A" PLASTIC BOW	B48-PH		45	G.M. CHEVY NOVA 1986-88 DOOR & TRUNK	B56-NP		34
G.M. TRUNK "B"	B49		33	G.M. CHEVY GEO SPECTRUM 1985-89	B53-NP		34
G.M. TRUNK "B"	B49-NP	+	33	G.M. CHEVY, GMC T-SERIES MEDIUM DUTY TRUCK 1984 ON	B54-NP		34
G.M. TRUNK "B" PLASTIC BOW	B49-PH		45	G.M. GEO METRO, SUZ. SWIFT 1989-97, GEO STORM 1990-93	B65-NP		34
G.M. IGNITION & DOOR "C"	B50		33	G.M. GEO PRIZM 1989-92	B72-NP		34
G.M. IGNITION & DOOR "C"	B50-NP	+	33	G.M. GEO PRIZM 1993-97	B80-NP		35
G.M. IGNITION & DOOR "C" PLASTIC BOW	B50-PH		45	G.M. GEO, CHEVY TRACKER 1989-04, CHEVY METRO 1998-01	B69-NP		34
G.M. TRUNK "D"	B51		33	G.M. OLDS INTRIGUE 1998-02	B93		35
G.M. TRUNK "D"	B51-NP	+	33	G.M. OLDS INTRIGUE 1998-02	B93-NP		35
G.M. TRUNK "D" PLASTIC BOW	B51-PH		45	G.M. PONTIAC GRAND AM, BUICK SKYLARK, OLDS ACHIEVA 1994 IGNITION	B82		35
G.M. IGNITION & DOOR "E"	B44		33	G.M. PONTIAC GRAND AM, BUICK SKYLARK, OLDS ACHIEVA 1994 IGNITION	B82-NP		35
G.M. IGNITION & DOOR "E"	B44-NP	+	33				
G.M. IGNITION & DOOR "E" PLASTIC BOW	B44-PH		45				
G.M. TRUNK "H"	B45		33				
G.M. TRUNK "H"	B45-NP	+	33				
G.M. TRUNK "H" PLASTIC BOW	B45-PH		45				
G.M. IGNITION & DOOR "J"	B46		33				
G.M. IGNITION & DOOR "J"	B46-NP	+	33				
G.M. IGNITION & DOOR "J" PLASTIC BOW	B46-PH		45				
G.M. TRUNK "K"	B47		33				
G.M. TRUNK "K"	B47-NP	+	33				

MANUFACTURER	JET	DITTO	PAGE	MANUFACTURER	JET	DITTO	PAGE
G.M. PONTIAC GRAND AM, BUICK SKYLARK, OLDS ACHIEVA 1994 IGNITION PLASTIC BOW	B82-PH		45	G.M. PONTIAC GRAND PRIX 2004 ON, BUICK LaCROSSE/ALLURE 2005 ON TRANSPONDER KEY FOR SMART CLONE	B107-N-PHT		50
G.M. PONTIAC GRAND AM, BUICK SKYLARK, OLDS ACHIEVA 1995 IGNITION	B86		35	G.M. PONTIAC GRAND PRIX 2004 ON TRANSPONDER KEY W/LOGO	GMX367-PHT		51
G.M. PONTIAC GRAND AM, BUICK SKYLARK, OLDS ACHIEVA 1995 IGNITION	B86-NP		35	G.M. VATS DOUBLE-SIDED KEY WITH PELLETT #2	B82-P2		45
G.M. PONTIAC GRAND AM, BUICK SKYLARK, OLDS ACHIEVA 1995 IGNITION PLASTIC BOW	B86-PH		45	G.M. VATS DOUBLE-SIDED KEY WITH PELLETT #3	B82-P3		45
G.M. PONTIAC GRAND PRIX 1997-99	B92		35	G.M. VATS DOUBLE-SIDED KEY WITH PELLETT #4	B82-P4		45
G.M. PONTIAC GRAND PRIX 1997-99	B92-NP		35	G.M. VATS DOUBLE-SIDED KEY WITH PELLETT #5	B82-P5		45
G.M. PONTIAC LEMANS 1988-93	B61-NP		34	G.M. VATS DOUBLE-SIDED KEY WITH PELLETT #6	B82-P6		45
G.M. SATURN 1991-94	B76-NP		34	G.M. VATS DOUBLE-SIDED KEY WITH PELLETT #7	B82-P7		45
G.M. SATURN 1995-96	B88-NP		35	G.M. VATS DOUBLE-SIDED KEY WITH PELLETT #8	B82-P8		45
G.M. SATURN ION 2003 ON	B106-NP		36	G.M. VATS DOUBLE-SIDED KEY WITH PELLETT #9	B82-P9		45
G.M. SATURN S-SERIES 1997-02, L-SERIES 2000-04, VUE 2002 ON	B96-NP		35	G.M. VATS DOUBLE-SIDED KEY WITH PELLETT #10	B82-P10		45
G.M. SATURN S-SERIES 1997-02, L-SERIES 2000-04, VUE 2002 ON PLASTIC BOW	B96-PH		46	G.M. VATS DOUBLE-SIDED KEY WITH PELLETT #11	B82-P11		45
G.M. TRUCKS & SUV'S 1995-98, LARGE VANS 1996-98	B83		35	G.M. VATS DOUBLE-SIDED KEY WITH PELLETT #12	B82-P12		45
G.M. TRUCKS & SUV'S 1995-98, LARGE VANS 1996-98	B83-NP		35	G.M. VATS DOUBLE-SIDED KEY WITH PELLETT #13	B82-P13		45
G.M. TRUCKS, SUV'S & LARGE VANS 1999 ON	B102		36	G.M. VATS DOUBLE-SIDED KEY WITH PELLETT #14	B82-P14		45
G.M. TRUCKS, SUV'S & LARGE VANS 1999 ON	B102-NP		36	G.M. VATS DOUBLE-SIDED KEY WITH PELLETT #15	B82-P15		45
G.M. TRUCKS, SUV'S & LARGE VANS 1999 ON PLASTIC BOW	B102-PH		46	G.M. VATS SINGLE-SIDED KEY WITH PELLETT #1	B62-P1		45
G.M. TRUCKS, SUV'S - SOME MODELS 1999 ON CONSOLE KEY	CON1		36	G.M. VATS SINGLE-SIDED KEY WITH PELLETT #2	B62-P2		45
G.M. BUICK LUCERNE 2006 ON "CIRCLE PLUS" TRANSPONDER KEY WITH LOGO	GMX222CP-PHT		51	G.M. VATS SINGLE-SIDED KEY WITH PELLETT #3	B62-P3		45
G.M. BUICK PARK AVENUE 1997-05, CHEVY VENTURE, PONTIAC MONTANA 1999-05, OLDS SILHOUETTE 1999-04 MASTER TRANSPONDER KEY	B97-PHT		50	G.M. VATS SINGLE-SIDED KEY WITH PELLETT #4	B62-P4		45
G.M. BUICK PARK AVENUE 1997-05, CHEVY VENTURE, PONTIAC MONTANA 1999-05, OLDS SILHOUETTE 1999-04 VALET TRANSPONDER KEY	B98V-PHT		50	G.M. VATS SINGLE-SIDED KEY WITH PELLETT #5	B62-P5		45
G.M. CADILLAC CATERA 1997-99 TRANSPONDER KEY	T10HF54-N-PHT		49	G.M. VATS SINGLE-SIDED KEY WITH PELLETT #6	B62-P6		45
G.M. CADILLAC CTS 2003 ON TRANSPONDER KEY WITH LOGO	GMX320-PHT		51	G.M. VATS SINGLE-SIDED KEY WITH PELLETT #7	B62-P7		45
G.M. CADILLAC DTS 2006 ON "CIRCLE PLUS" TRANSPONDER KEY W/LOGO	GMX272CP-PHT		51	G.M. VATS SINGLE-SIDED KEY WITH PELLETT #8	B62-P8		45
G.M. CADILLAC SEVILLE 1998-04, BUICK LESABRE, CADILLAC DE VILLE, PONTIAC BONNEVILLE 2000-05, & OTHER MODELS MASTER TRANSPONDER KEY	B99-PHT		50	G.M. VATS SINGLE-SIDED KEY WITH PELLETT #9	B62-P9		45
G.M. CADILLAC SEVILLE 1998-04, BUICK LESABRE, CADILLAC DE VILLE, PONTIAC BONNEVILLE 2000-05, & OTHER MODELS VALET TRANSPONDER KEY	B100V-PHT		50	G.M. VATS SINGLE-SIDED KEY WITH PELLETT #10	B62-P10		45
G.M. CADILLAC SRX 2004 ON TRANSPONDER KEY W/LOGO	GMT265-PHT		51	G.M. VATS SINGLE-SIDED KEY WITH PELLETT #11	B62-P11		45
G.M. "CIRCLE PLUS" TRANSPONDER KEY W/NO LOGO - 2006+ IMPALA, SOLSTICE, LUCERNE, DTS, ETC.	B112-CP-PHT		51	G.M. VATS SINGLE-SIDED KEY WITH PELLETT #12	B62-P12		45
G.M. CHEVROLET MALIBU 2004-05 TRANSPONDER KEY W/LOGO	GMX380-PHT		51	G.M. VATS SINGLE-SIDED KEY WITH PELLETT #13	B62-P13		45
G.M. CHEVY MALIBU 2004 ON, IMPALA 2006 ON "CIRCLE PLUS" TRANSPONDER KEY W/LOGO	GMX380CP-PHT		51	G.M. VATS SINGLE-SIDED KEY WITH PELLETT #14	B62-P14		45
G.M. PONTIAC G6 2005 TRANSPONDER KEY W/LOGO	GMX381-PHT		51	G.M. VATS SINGLE-SIDED KEY WITH PELLETT #15	B62-P15		45
G.M. PONTIAC G6 2005 ON, SOLSTICE 2006 ON "CIRCLE PLUS" TRANSPONDER KEY W/LOGO	GMX381CP-PHT		51	HARLEY-DAVIDSON 1994 ON, BUELL 1995-02 MODELS W/TUBULAR LOCKS (BRASS)	137B		36
G.M. PONTIAC GRAND PRIX 2000-03 TRANSPONDER KEY	B103-PHT		50	HARLEY-DAVIDSON 1994 ON, BUELL 1995-02 MODELS W/TUBULAR LOCKS (STEEL)	137S		36
G.M. PONTIAC GRAND PRIX 2004 ON, BUICK LaCROSSE/ALLURE 2005 ON TRANSPONDER KEY	B107-PHT		50	HARLOC 5 PIN	HR1	+	10

MANUFACTURER	JET	DITTO	PAGE	MANUFACTURER	JET	DITTO	PAGE
HONDA ACCORD 1993-97, CIVIC 1992-00, CR-V 1997-01, PRELUDE 1992-96, GOLD WING MOTORCYCLE '01 ON PLASTIC BOW	HD103-PH		46	ISUZU RODEO 1991-MID '95, PICK-UP 1990-'95 (U.S. Built Models Only), HONDA PASSPORT 1994-MID '95	B74-NP		39
HONDA ACCORD, ODYSSEY 1998-02, CIVIC 2001-02, PRELUDE 1997-01 TRANSPONDER KEY	HD106-N-PHT		51	KAWASAKI MOTORCYCLE	KA14-NP		39
HONDA HD106-N-PHT LESS CHIP	HD106-PHT-LC		51	KAWASAKI MOTORCYCLE	KA15-NP		39
HONDA CR-V 2002-06 TRANSPONDER KEY	HD110-N-PHT		51	KEIL 2K 5 PIN	K1		12
HONDA MOTORCYCLE, ATV, KYMCO ATV	HD74-NP		38	KEIL 2KK 5 PIN	K2		12
HONDA MOTORCYCLE, ATV, KYMCO ATV	HD75-NP		38	KIA AMANTI 2004 ON TRANSPONDER KEY FOR SMART CLONE W/CRYPTO SW	KK7-N-PHT		52
HONDA TRY OUT KEY (B FOR BLADE)	HD110-B		51	KIA RIO CINCO 2003 ON	KK5-NP		39
HUDSON, AUTH 46X, FLORENCE 5 PIN	HL1	+	10	KIA SEPHIA 1994-97	KK1-NP		39
HUDSON HL1- FOR IMPORTED MAIL BOX LOCKS	HL1-M		10	KIA SEPHIA 1998-01, SPECTRA 2000-04, RIO 2001-05	KK3-NP		39
HYUNDAI 1986-89 EXCEL	HY2-NP		38	KIA SPORTAGE 1995-'00	KK2-NP		39
HYUNDAI 1986-89 EXCEL PLASTIC BOW	HY2-PH		46	KIA SPORTAGE 2001-02	KK4-NP		39
HYUNDAI 1989-94 SONATA	HY4-NP		38	KUMAHIRA SAFE CO., INC.	SEC-1-NS		27/28
HYUNDAI 1990-94 EXCEL, 1991-95 SCOUPE	HY5-NP		38	KUMAHIRA SAFE CO., INC.	SEC-2-NS		27/28
HYUNDAI 1992-95 ELANTRA	HY6-NP		38	KWIKSET 1-1063 5 PIN	1063KW-BR		12
HYUNDAI ACCENT 1995-99	HY13-NP		38	KWIKSET 1-1063 NP 5 PIN	1063KW-NP		12
HYUNDAI ACCENT 1995-99 PLASTIC BOW	HY13-PH		46	KWIKSET 1-1063 5 PIN	KW1+	+	12
HYUNDAI ACCENT, KIA RIO 2006	HY16-NP		38	KWIKSET 1-1063-NP 5 PIN	KW1+-NP	+	12
HYUNDAI ACCENT, KIA RIO 2006 PLASTIC BOW	HY16-PH		46	KWIKSET 1-1063 5 PIN	KW1-JET		12
HYUNDAI ELANTRA 1996 ON, TIBURON 1997 ON	HY14-NP		38	KWIKSET 1-1063-NP 5 PIN	KW1-JET-NP		12
HYUNDAI ELANTRA 1996 ON, TIBURON 1997 ON PLASTIC BOW	HY14-PH		46	KWIKSET 1-1063 HOTEL BOW 5 PIN	KW1-RH		58
HYUNDAI ELANTRA 2007	HY17-NP		38	KWIKSET 5 PIN LARGE BOW 6275	KW6	+	12
HYUNDAI ELANTRA 2007 PLASTIC BOW	HY17-PH		46	KWIKSET 6 PIN	KW5	+	12
HYUNDAI SONATA 1995-05, SANTA FE, XG 300/350, KIA OPTIMA 2001 ON	HY12-NP		38	KWIKSET FOR IMPORTED LOCKS W/KWIKSET GROOVING	KW1-IMP	+	12
HYUNDAI SONATA 1995-05, SANTA FE, XG 300/350, KIA OPTIMA 2001 ON PLASTIC BOW	HY12-PH		46	KWIKSET FOR IMPORTED LOCKS	CO-KW1		12
HYUNDAI SONATA 2006	HY15-NP		38	KWIKSET PLASTIC HEAD COLOR ASSORTMENT	KW1-PHC		12/22
HYUNDAI SONATA 2006 PLASTIC BOW	HY15-PH		46	KWIKSET/TITAN 6 PIN 1-7743	KW9		12
ILCO 1054DL 5 PIN	IN35	+	11	KWIKSET/TITAN 6 PIN NP 1-7743	KW9-NP	+	12
ILCO 1054F, KEIL 159AA 5 PIN	IN1	+	11	KWIKSET/TITAN 6 PIN REKEYING TOOL	KW9-RT-NP		12
ILCO 1054FN 5 PIN	IN28	+	11	KWIKSET/TITAN 6 PIN 1-8260	KW10		12
ILCO 1054K 5 PIN	IN20	+	11	KWIKSET/TITAN 6 PIN NP 1-8260	KW10-NP	+	12
ILCO 1054MT 5 PIN	IN33	+	11	KWIKSET/TITAN 6 PIN NS 1-8260	8260KW-NS		12
ILCO 1054UN 5 PIN	IN29	+	11	KWIKSET/TITAN 6 PIN NP	KW11-NP	+	12
ILCO L1054B 5 PIN	IN8	+	11	LeFEBURE - 7300, 7700, RENTER	LEB-1-NS		27/28
ILCO X1054F 5 PIN	IN18	+	11	LeFEBURE - 7300, 7700, RENTER	LEB-2-NS		27/28
ILCO X1054K 5 PIN	IN3	+	11	LeFEBURE - 7300, 7700, RENTER	LEB-3-NS		27/28
ILCO FOR IMPORTED MASTER TYPE PADLOCKS	M1-TG		11	LeFEBURE - 7300, 7700, RENTER	LEB-4-NS		27/28
ILCO UNICAN SAFE DEPOSIT	ILC-1-NS		27/28	LeFEBURE - 7300, 7700, RENTER	LEB-6-NS		27/29
ILLINOIS, TIMBERLINE SUPPLY	IL11-NP		11	LeFEBURE - 7300, 7700, RENTER	LEB-7-NS		27/29
ILLINOIS 110	IL1	+	11	LEXUS 1990-96 (ALL), ES, GS, LX, SC 1997, MAZDA MILLENIA PLASTIC BOW	LXP90-PH		48
ILLINOIS 210	IL210	+	11	LEXUS LS400 1997, SC 1998-00, ES300 1998-01 TRANSPONDER KEY	TR49-PHT		52
ILLINOIS 210M MASTER	IL210M	+	11	LEXUS LS400 1997, SC 1998-00, ES300 1998-01 TRANSPONDER KEY FOR SMART CLONE	TR49-N-PHT		52
ILLINOIS 220 SHORT	IL220	+	11	LEXUS TR49-PHT LESS CHIP	TR49-PHT-LC		52
ILLINOIS 260	IL260	+	11	LEXUS LS 1998-00, GS 1998-05, RX 1999-03, IS 2001-05, ES300 2002-03 TRANSPONDER KEY	TR48-PHT		52
ILLINOIS 360	IL360	+	11	LEXUS LS 1998-00, GS 1998-05, RX 1999-03, IS 2001-05, ES300 2002-03 TRANSPONDER KEY FOR SMART CLONE	TR48-N-PHT		52
ILLINOIS 510	IL510	+	11	LEXUS TR48-PHT LESS CHIP	TR48-PHT-LC		52
ILLINOIS 610	IL610	+	11	LEXUS LS430 2001-06, SC430 2002 ON, GX470, LX470 2003 ON TRANSPONDER KEY FOR SMART CLONE W/CRYPTO SW	TR60-N-PHT		52
INFINITI Q45 1997-01 TRANSPONDER KEY	INFQ45-PHT		52	LEXUS TRYOUT KEY (BLADE ONLY)	TR48/49-B		52
INFINITI Q45 1997-01 TRANSPONDER KEY FOR SMART CLONE	INFQ45-N-PHT		51	LOCKWOOD B308 5 PIN	L1	+	12
ISUZU F-SERIES MEDIUM DUTY TRUCK 1984 ON	B54-NP		39	LOCKWOOD B310 6 PIN	L4	+	12
ISUZU I-MARK 1981-84, IMPULSE 1983-89, TROOPER 1984-91	DC3-NP		39	LOCKWOOD B346 (1004AL) 7 PIN	L5		12
ISUZU I-MARK 1985-89	B53-NP		39				
ISUZU IMPULSE, STYLUS 1990-93, N-SERIES TRUCK 1989 ON, TROOPER 1992-02	B65-NP		39				

MANUFACTURER	JET	DITTO	PAGE	MANUFACTURER	JET	DITTO	PAGE
SCHLAGE 35-101FG (924G) 6 PIN	101-FG-NS	+	17/26	TOYOTA CAMRY 1992-06, COROLLA 1993-04, CELICA 1994-05, AVALON 1995-04 PLASTIC BOW	TR47-PH		48
SCHLAGE 35-101G (924G) 6 PIN	101-G-NS		17/26	TOYOTA COROLLA WAGON 1993-96	TR53-NP		42
SCHLAGE 35-101H (924H) 6 PIN MASTER FOR C, CE & E KEYWAYS	101-H-NS	+	17/26	TOYOTA CAMRY 1998 ON, AVALON 1998-04, SIENNA, SOLARA 1999-03 TRANSPONDER KEY	TR47-PHT		53
SCHLAGE 35-101L (924L) 6 PIN MASTER FOR C, CE, E, FF, F, FG & G KEYWAYS	SC20	+	17	TOYOTA CAMRY 1998 ON, AVALON 1998-04, SIENNA, SOLARA 1999-03 TRANSPONDER KEY FOR SMART CLONE	TR47-N-PHT		53
SCHLAGE 35-101L 6 PIN MASTER FOR C, CE, E, EE, F, FG, & G KEYWAYS	101-L-NS		17/26	TOYOTA TR47-PHT LESS CHIP	TR47-PHT-LC		53
SCHLAGE 35-180 (920A)	SC6	+	17	TOYOTA CAMRY, 4RUNNER, LAND CRUISER, SEQUOIA 2003 ON TRANSPONDER KEY FOR SMART CLONE W/CRYPTO SW	TR51-N-PHT		53
SCHLAGE 35-200 (927W)	SC22	+	17	TOYOTA MR2 SPYDER 2000-05 TRANSPONDER KEY	TR40-PHT		53
SCHLAGE LOCKOUT KEY SC19 (100L) MASTER	SC-LO		17	TRIMARK RV'S & MOTOR HOMES (#14264-01-2001) (KS200)	TM200		36
SCHLAGE PLASTIC HEAD COLOR ASSORTMENT	SC1-PHC		17/22	TRIMARK RV'S & MOTOR HOMES (#14264-03-2001) (KS700) 6 PIN	TM700		36
SEGAL 62 6 PIN	6SE4		17	TRIMARK RV'S & MOTOR HOMES (#14264-04-2001) (KS300)	TM300		36
SEGAL 69 6 PIN	SE8		17	TRIMARK RV'S & MOTOR HOMES (#14264-06-2001) (KS400)	TM400		36
SEGAL K9 5 PIN	SE1+	+	17	TRIMARK RV'S & MOTOR HOMES (#14264-07-2001) (KS100)	TM100		36
SEGAL K9 5 PIN	SE1-JET		17	TRIMARK RV'S & MOTOR HOMES (#14264-08-2001) (KS110) 6 PIN	TM110		36
SEGAL K9 5 PIN	SE1-NP		17	TRIMARK RV'S & MOTOR HOMES (#14472-05-2001) (KS130, TRK2)	TM130		36
SEGAL K9 MASTER - SQUARE HEAD	5SE3		17	TRIMARK RV'S & MOTOR HOMES (#14472-07-2001) (KS150)	TM150		36
SEGAL K9 MASTER FOR IMPORTED CYLINDER	SE1-M		18	TRIMARK RV'S & MOTOR HOMES (#14472-09-2001) (KS180, TRK3)	TM180		36
SHAW WALKER FILE CABINET	SW1	+	18	VIRO 11D 4 PIN	191B	+	18
SLAYMAKER K230	SL1	+	18	VIRO 13D 5 PIN	191	+	18
SUBARU 1970-81	SR1-NP		41	VIRO, GUARD, A-A, 15D 5 PIN	L191A	+	18
SUBARU 1982-84 (ALL), BRAT 1985-87	DA23-NP		41	VIRO, WALSCO, (REV. L191A) 15S 5 PIN	LR191A	+	18
SUBARU 1985-97, LEGACY 1998-99, IMPREZA 1998-01	DA25-NP		41	VOLKSWAGEN 1966-70 BEETLE	V26K-NP		42
SUBARU 1985-97, LEGACY 1998-99, IMPREZA 1998-01	DA25-PH		47	VOLKSWAGEN 1971-79 BEETLE	V28M-NP		42
SUBARU FORESTER 1998 ON, LEGACY, OUTBACK 2000 ON, IMPREZA 2002 ON	SR8-NP		41	VOLKSWAGEN 1971-79 BUS	V29R-NP		42
SUBARU FORESTER 1998 ON, LEGACY, OUTBACK 2000 ON, IMPREZA 2002 ON PLASTIC BOW	SR8-PH		47	VOLKSWAGEN 1971-87 (MOST), QUANTUM, SCIROCCO 1988, FOX 1988-93	V30-NP, PA8-NP		42
SUBARU FORESTER XT, IMPREZA WRX STI, LEGACY GT, OUTBACK XT, 3.0R 2005 ON TRANSPONDER KEY FOR SMART CLONE W/CRYPTO SW	SR8-N-PHT		53	VOLKSWAGEN 1971-87 (MOST), QUANTUM, SCIROCCO 1988, FOX 1988-93 PLASTIC BOW	V30-PH		48
SUZUKI MOTORCYCLE	SUZ11-NP		41	VOLKSWAGEN 1988-98, EUROVAN 1993-00 MASTER	V37-NP		43
SUZUKI SAMURAI	DC3-NP		41	VOLKSWAGEN 1988-98, EUROVAN 1993-00 MASTER	V37-PH		48
SUZUKI SIDEKICK 1989-98, SWIFT 1998-01, VITARA/GRAND VITARA 1999-05, XL-7 2001-06	SUZ17-NP		41	VOLKSWAGEN 1998-99 NEW BEETLE, PASSAT PLASTIC BOW	HU66VW-PH		48
TAYLOR 111E 5 PIN	T3		18	VOLKSWAGEN GOLF/GTI, JETTA, PASSAT, NEW BEETLE 2000 ON TRANSPONDER KEY	HU67-PHT		53
TAYLOR 111GE 5 PIN	T7	+	18	VOLKSWAGEN / AUDI HU67-PHT LESS CHIP	HU67-PHT-LC		53
TESA 5 PIN	R59		18	VOLKSWAGEN / AUDI TRYOUT KEY (BLADE ONLY)	HU66VW-B		53
TOYOTA 1969-82	TR20-NP		42	VOLVO 1973-85 240 SERIES SECONDARY	VL4-NP		43
TOYOTA 1969-82 PLASTIC BOW	TR20-PH		47	VOLVO 1977-85 240 SERIES PRIMARY, 1983-87 760, 780 VALET	VL6-NP		43
TOYOTA 1983-90 (LONGER TR20)	TR33-NP		42	VOLVO 1983-87 760, 780, 1985-92 740, 1986-93 240 PRIMARY	VL8-NP		43
TOYOTA 1983-90 (LONGER TR20) PLASTIC BOW	TR33-PH		47	VOLVO 1988-91 760, 780, 1991-97 940SE, 960, 1993-97 850, 1998 (ALL) PLASTIC BOW	S66NN-PH		48
TOYOTA, CHEVY LUV	TR23-NP		42	WEISER 1555, (KB1555-B) 5 PIN SQUARE HEAD	P1555-NP		18
TOYOTA COROLLA WAGON PRE-1984, CRESSIDA WAGON 1979-87, VAN 1984-89	TR25-NP		42	WEISER 1555, (KB1555-B) 5 PIN SQUARE HEAD	WR5	+	18
TOYOTA CORONA 1972-82, CRESSIDA SEDAN 1979-88, CAMRY 1983-91	TR37-NP		42	WEISER 1555, FALCON 5 PIN	WR3	+	18
TOYOTA CORONA 1972-82, CRESSIDA SEDAN 1979-88, CAMRY 1983-91 PLASTIC BOW	TR37-PH		47	WEISER 1555, FALCON 5 PIN	WR3-NP		18
TOYOTA 1987-90 CELICA & TERCEL LIFTBACKS, 1988-92 COROLLA WAGON 2 WHEEL DRIVE	TR39-NP		42	WEISER 1555, FALCON 5 PIN HOTEL BOW	WR3-RH		58
TOYOTA 1988-90 COROLLA SEDAN & COUPE, 1988-92 COROLLA WAGON 4WD, 2000-02 ECHO	TR40-NP		42	WEISER 1559, FALCON 6 PIN SQUARE HEAD	WR6	+	18
TOYOTA 1988-90 COROLLA SEDAN & COUPE, 1988-92 COROLLA WAGON 4WD, 2000-02 ECHO PLASTIC BOW	TR40-PH		47	WEISER PLASTIC HEAD COLOR COLLECTION	WR5-PHC		18/22
TOYOTA 1990-93 CELICA COUPE & CONVERTIBLE, 1990-95 4RUNNER, 1991-92 COROLLA SEDAN & COUPE	TR44-NP		42				
TOYOTA 1991-93 CELICA LIFTBACK, 1991-99 TERCEL, 1991-97 PREVIA	TR46-NP		42				
TOYOTA CAMRY 1992-06, COROLLA 1993-04, CELICA 1994-05, AVALON 1995-04	TR47-NP		42				

MANUFACTURER	JET	DITTO	PAGE	MANUFACTURER	JET	DITTO	PAGE
WEISER 1555, (KB1555-B) 5 PIN SQUARE HEAD	P1555-NP		18	WEISER 1555, FALCON 5 PIN	WR3	+	18
WEISER 1555, (KB1555-B) 5 PIN SQUARE HEAD	WR5	+	18	WEISER 1555, FALCON 5 PIN	WR3-NP		18
WEISER 1555, FALCON 5 PIN	WR3	+	18	WEISER 1555, FALCON 5 PIN HOTEL BOW	WR3-RH		58
WEISER 1555, FALCON 5 PIN	WR3-NP		18	WEISER 1559, FALCON 6 PIN SQUARE HEAD	WR6	+	18
WEISER 1555, FALCON 5 PIN HOTEL BOW	WR3-RH		58	WEISER PLASTIC HEAD COLOR COLLECTION	WR5-PHC		18/22
WEISER 1559, FALCON 6 PIN SQUARE HEAD	WR6	+	18				
WEISER PLASTIC HEAD COLOR COLLECTION	WR5-PHC		18/22				
WELCH W9805/5K 5 PIN	WE1	+	18	WELCH W9805/5K 5 PIN	WE1	+	18
WESLOCK 12344 (4425) 5 PIN	WK2	+	18	WESLOCK 12344 (4425) 5 PIN	WK2	+	18
WILSON BOHANNAN 620A 5 PIN	WB1A	+	18	WILSON BOHANNAN 620A 5 PIN	WB1A	+	18
WILSON BOHANNAN 620B 5 PIN	WB1B	+	18	WILSON BOHANNAN 620B 5 PIN	WB1B	+	18
WILSON BOHANNAN 620C 5 PIN	WB1C	+	18	WILSON BOHANNAN 620C 5 PIN	WB1C	+	18
WILSON BOHANNAN 621A 6 PIN	WB2A	+	18	WILSON BOHANNAN 621A 6 PIN	WB2A	+	18
WILSON BOHANNAN 621B 6 PIN	WB2B	+	18	WILSON BOHANNAN 621B 6 PIN	WB2B	+	18
WILSON BOHANNAN 621C 6 PIN	WB2C	+	18	WILSON BOHANNAN 621C 6 PIN	WB2C	+	18
XL LETTER BOX	XL7	+	19	XL LETTER BOX	XL7	+	19
YALE 8 (8E1R) 5 PIN	Y1+	+	19	YALE 8 (8E1R) 5 PIN	Y1+	+	19
YALE 8 MASTER 5 PIN	Y1M		19	YALE 8 MASTER 5 PIN	Y1M		19
YALE 8E1L (REVERSE OF Y1) 5 PIN	Y1R		19	YALE 8E1L (REVERSE OF Y1) 5 PIN	Y1R		19
YALE 8 5 PIN E BOW	Y1E		19	YALE 8 5 PIN E BOW	Y1E		19
YALE 9 1/2 (9E1R) 4 PIN E BOW	Y220		19	YALE 9 1/2 (9E1R) 4 PIN E BOW	Y220		19
YALE 11 (11E1R) 6 PIN	Y2	+	19	YALE 11 (11E1R) 6 PIN	Y2	+	19
YALE 11 6 PIN E BOW	Y2E		19	YALE 11 6 PIN E BOW	Y2E		19
YALE 11GA 6 PIN	Y78	+	19	YALE 11GA 6 PIN	Y78	+	19
YALE 11GMK 6 PIN MASTER FOR WHOLE G-SERIES	Y4	+	19	YALE 11GMK 6 PIN MASTER FOR WHOLE G-SERIES	Y4	+	19
YALE 11GST MASTER 6 PIN	Y227	+	20	YALE 11GST MASTER 6 PIN	Y227	+	20
YALE 12 1/2 E3R 6 PIN	Y54		19	YALE 12 1/2 E3R 6 PIN	Y54		19
YALE 13E3R 5 PIN	Y52		19	YALE 13E3R 5 PIN	Y52		19
YALE 19E1R 3 PIN	Y221	+	20	YALE 19E1R 3 PIN	Y221	+	20
YALE 19E1R 3 PIN	19-NS		19/26	YALE 19E1R 3 PIN	19-NS		19/26
YALE 9114/9116 5 PIN	Y11	+	20	YALE 9114/9116 5 PIN	Y11	+	20
YALE 9119 5 PIN	Y13	+	20	YALE 9119 5 PIN	Y13	+	20
YALE 9279/1019B10L 5 PIN	Y14	+	20	YALE 9279/1019B10L 5 PIN	Y14	+	20
YALE 9290/1019F8R 5 PIN	Y103	+	20	YALE 9290/1019F8R 5 PIN	Y103	+	20
YALE X10 1/2E3R 4 PIN	Y6	+	19	YALE X10 1/2E3R 4 PIN	Y6	+	19
YALE E10 4 PIN E BOW	Y6E	+	19	YALE E10 4 PIN E BOW	Y6E	+	19
YALE E10E3R 4 PIN	Y5		19	YALE E10E3R 4 PIN	Y5		19
YALE E12 1/2 6 PIN E BOW	Y54E	+	19	YALE E12 1/2 6 PIN E BOW	Y54E	+	19
YALE E13 5 PIN E BOW	Y52E	+	19	YALE E13 5 PIN E BOW	Y52E	+	19
YALE JR 9278/1019B10R 5 PIN	Y12	+	20	YALE JR 9278/1019B10R 5 PIN	Y12	+	20
YALE JR 9278/1019B10R GAS	Y12G		30	YALE JR 9278/1019B10R GAS	Y12G		30
YALE JR 9278/1019B10R GAS	Y12G-NP		30	YALE JR 9278/1019B10R GAS	Y12G-NP		30
YALE RN8-NP (5 PIN)	8-NP		19	YALE RN8-NP (5 PIN)	8-NP		19
YALE RN8-NS (5 PIN)	8-NS		19/26	YALE RN8-NS (5 PIN)	8-NS		19/26
YALE RN11-NP (6 PIN)	11-NP		19	YALE RN11-NP (6 PIN)	11-NP		19
YALE RN11-NS (6 PIN)	11-NS		19/26	YALE RN11-NS (6 PIN)	11-NS		19/26
YALE RN11GA-NP (6 PIN)	11-GA-NP		19	YALE RN11GA-NP (6 PIN)	11-GA-NP		19
YALE RN11GA-NS (6 PIN)	11-GA-NS	+	20/26	YALE RN11GA-NS (6 PIN)	11-GA-NS	+	20/26
YALE RN11GB-NS (6 PIN)	11-GB-NS	+	20/26	YALE RN11GB-NS (6 PIN)	11-GB-NS	+	20/26
YALE RN11GC-NS (6 PIN)	11-GC-NS	+	20/26	YALE RN11GC-NS (6 PIN)	11-GC-NS	+	20/26
YALE RN11GD-NS (6 PIN)	11-GD-NS	+	20/26	YALE RN11GD-NS (6 PIN)	11-GD-NS	+	20/26
YALE RN11GE-NS (6 PIN)	11-GE-NS	+	20/26	YALE RN11GE-NS (6 PIN)	11-GE-NS	+	20/26
YALE RN11GF-NS (6 PIN)	11-GF-NS	+	20/26	YALE RN11GF-NS (6 PIN)	11-GF-NS	+	20/26
YALE RN11GG-NS (6 PIN)	11-GG-NS	+	20/26	YALE RN11GG-NS (6 PIN)	11-GG-NS	+	20/26
YALE RN11GH-NS (6 PIN)	11-GH-NS	+	20/26	YALE RN11GH-NS (6 PIN)	11-GH-NS	+	20/26
YALE RN11GK-NS (6 PIN)	11-GK-NS	+	20/26	YALE RN11GK-NS (6 PIN)	11-GK-NS	+	20/26
YALE RN11GMK-NS (6 PIN) MASTER FOR WHOLE G-SERIES	11-GMK-NS		20/26	YALE RN11GMK-NS (6 PIN) MASTER FOR WHOLE G-SERIES	11-GMK-NS		20/26
YALE RN11SA-NS (6 PIN)	11-SA-NS		20/26	YALE RN11SA-NS (6 PIN)	11-SA-NS		20/26
YALE RN11SB-NS (6 PIN)	11-SB-NS		20/26	YALE RN11SB-NS (6 PIN)	11-SB-NS		20/26
YALE RN11SC-NS (6 PIN)	11-SC-NS		20/26	YALE RN11SC-NS (6 PIN)	11-SC-NS		20/26
YALE RN11SD-NS (6 PIN)	11-SD-NS		20/26	YALE RN11SD-NS (6 PIN)	11-SD-NS		20/26
YALE RN11SE-NS (6 PIN)	11-SE-NS		20/26	YALE RN11SE-NS (6 PIN)	11-SE-NS		20/26
YALE RN11SF-NS (6 PIN)	11-SF-NS		20/26	YALE RN11SF-NS (6 PIN)	11-SF-NS		20/26
YALE RN11SG-NS (6 PIN)	11-SG-NS		20/26	YALE RN11SG-NS (6 PIN)	11-SG-NS		20/26
YALE RN11SH-NS (6 PIN)	11-SH-NS		20/26	YALE RN11SH-NS (6 PIN)	11-SH-NS		20/26
YALE RN11SK-NS (6 PIN)	11-SK-NS		20/26	YALE RN11SK-NS (6 PIN)	11-SK-NS		20/26
YALE RN11SMK-NS (6 PIN) MASTER FOR WHOLE S-SERIES	11-SMK-NS		20/26	YALE RN11SMK-NS (6 PIN) MASTER FOR WHOLE S-SERIES	11-SMK-NS		20/26
YALE LOCKOUT KEY Y1 (8)	Y-LO		19	YALE LOCKOUT KEY Y1 (8)	Y-LO		19
YALE RESIDENTIAL 068004 W/KW1 KEYWAY, 5 PIN	Y1K-NP		19	YALE RESIDENTIAL 068004 W/KW1 KEYWAY, 5 PIN	Y1K-NP		19
YALE RESIDENTIAL 068003 W/KW1 KEYWAY, 6 PIN	Y2K-NP		19	YALE RESIDENTIAL 068003 W/KW1 KEYWAY, 6 PIN	Y2K-NP		19
YALE SAFE DEPOSIT	YAL-1-NS		27/29	YALE SAFE DEPOSIT	YAL-1-NS		27/29
YALE SAFE DEPOSIT	YAL-2-NS		27/29	YALE SAFE DEPOSIT	YAL-2-NS		27/29
YALE SAFE DEPOSIT	YAL-3-NS		27/29	YALE SAFE DEPOSIT	YAL-3-NS		27/29
YAMAHA MOTORCYCLE, ATV, POLARIS ATV	Y						

JET Silver Line - Nickel Silver Key Blanks

MANUFACTURER	JET	PAGE	MANUFACTURER	JET	PAGE
ARROW INTERCHANGEABLE CORE K11-1C	AR-1C-NS	4/23	CORBIN RUSSWIN D2-6 PIN	D2-6-NS	8/24
ARROW INTERCHANGEABLE CORE K11-1D	AR-1D-NS	4/23	CORBIN RUSSWIN D3-6 PIN	D3-6-NS	8/24
ARROW K6A 6 PIN	K6-NS	4/23	CORBIN RUSSWIN D4-6 PIN	D4-6-NS	8/24
ARROW K7 6 PIN	K7-NS	4/23	CORBIN RUSSWIN H1-6 PIN	H1-6-NS	8/24
BALDWIN 5 PIN W/SC1 KEYWAY	BAL-1-NS	4/23	CORBIN RUSSWIN H2-6 PIN	H2-6-NS	8/24
BEST 1A1A1	1A1A1-NS	5/24	CORBIN RUSSWIN H3-6 PIN	H3-6-NS	8/24
BEST 1A1A1B	1A1A1B-NS	5/24	CORBIN RUSSWIN H4-6 PIN	H4-6-NS	8/24
BEST 1A1B1	1A1B1-NS	5/24	CORBIN RUSSWIN H5-6 PIN	H5-6-NS	8/24
BEST 1A1B1B	1A1B1B-NS	5/24	CORBIN RUSSWIN H6-6 PIN	H6-6-NS	8/24
BEST 1A1BA1	1A1BA1-NS	5/23	CORBIN RUSSWIN H7-6 PIN	H7-6-NS	8/24
BEST 1A1C1	1A1C1-NS	5/24	CORBIN RUSSWIN H8-6 PIN	H8-6-NS	8/24
BEST 1A1C1B	1A1C1B-NS	5/24	CORBIN RUSSWIN L1-6 PIN	L1-6-NS	8/24
BEST 1A1D1	1A1D1-NS	5/24	CORBIN RUSSWIN L2-6 PIN	L2-6-NS	8/24
BEST 1A1D1B	1A1D1B-NS	5/24	CORBIN RUSSWIN L3-6 PIN	L3-6-NS	8/24
BEST 1A1DD1	1A1DD1-NS	5/24	CORBIN RUSSWIN L4-6 PIN	L4-6-NS	8/24
BEST 1A1DD1B	1A1DD1B-NS	5/24	CORBIN RUSSWIN L12-6 PIN	L12-6-NS	8/24
BEST 1A1DE1 (COMPOSITE)	1A1DE1-NS	5/23	CORBIN RUSSWIN L34-6 PIN	L34-6-NS	8/24
BEST 1A1E1	1A1E1-NS	5/24	CORBIN RUSSWIN L41-6 PIN	L41-6-NS	8/24
BEST 1A1E1B	1A1E1B-NS	5/24	DIEBOLD SAFE DEPOSIT	DIE-1-NS	26/28
BEST 1A1F1	1A1F1-NS	5/24	DIEBOLD SAFE DEPOSIT	DIE-2-NS	26/28
BEST 1A1F1B	1A1F1B-NS	5/24	DIEBOLD SAFE DEPOSIT	DIE-3-NS	26/28
BEST 1A1G1	1A1G1-NS	5/24	FALCON KB577E	KB577E-NS	10/25
BEST 1A1G1B	1A1G1B-NS	5/24	FALCON KB577F	KB577F-NS	10/25
BEST 1A1H1	1A1H1-NS	5/24	FALCON KB577G	KB577G-NS	10/25
BEST 1A1H1B	1A1H1B-NS	5/24	FALCON KB577J	KB577J-NS	10/25
BEST 1A1J1	1A1J1-NS	5/24	HERRING HALL MARVIN SAFE DEPOSIT	HHM-1-NS	26/28
BEST 1A1J1B	1A1J1B-NS	5/24	HERRING HALL MARVIN SAFE DEPOSIT	HHM-2-NS	26/28
BEST 1A1JK1 (COMPOSITE)	1A1JK1-NS	5/23	ILCO UNICAN SAFE DEPOSIT	IIC-1-NS	27/28
BEST 1A1K1	1A1K1-NS	5/24	KUMAHIRA SAFE CO., INC.	SEC-1-NS	27/28
BEST 1A1K1B	1A1K1B-NS	5/24	KUMAHIRA SAFE CO., INC.	SEC-2-NS	27/28
BEST 1A1L1	1A1L1-NS	5/24	KWIKSET-TITAN 6 PIN 1-8260	8260KW-NS	12/25
BEST 1A1L1B	1A1L1B-NS	5/24	LeFEBURE - 7300, 7700, RENTER	LEB-1-NS	27/28
BEST 1A1M1	1A1M1-NS	5/24	LeFEBURE - 7300, 7700, RENTER	LEB-2-NS	27/28
BEST 1A1M1B	1A1M1B-NS	5/24	LeFEBURE - 7300, 7700, RENTER	LEB-3-NS	27/28
BEST 1A1N1	1A1N1-NS	5/24	LeFEBURE - 7300, 7700, RENTER	LEB-4-NS	27/28
BEST 1A1N1B	1A1N1B-NS	5/24	LeFEBURE - 7300, 7700, RENTER	LEB-6-NS	27/29
BEST 1A1O1	1A1O1-NS	5/24	LeFEBURE - 7300, 7700, RENTER	LEB-7-NS	27/29
BEST 1A1O1B	1A1O1B-NS	5/24	MEDECO KY105-600 LEVEL 1 - 5 PIN	AIR-5-NS	14/25
BEST 1A1R1	1A1R1-NS	5/24	MEDECO KY106-600 LEVEL 1 - 6 PIN	AIR-6-NS	14/25
BEST 1A1R1B	1A1R1B-NS	5/24	MEDECO KY155-600-0401 LEVEL 2 - 5 PIN	SKY-5-NS	14/25
BEST 1A1TB1	1A1TB1-NS	5/24	MEDECO KY156-600-0401 LEVEL 2 - 6 PIN	SKY-6-NS	14/25
BEST 1A1TB1B	1A1TB1B-NS	5/24	MOSLER 5400 SERIES, 73731, PRECISION NO. MO1	MOS-1-NS	27/29
BEST 1A1TD1	1A1TD1-NS	5/24	MOSLER 5700 SERIES, 77588	MOS-2-NS	27/29
BEST 1A1TE1	1A1TE1-NS	5/24	MOSLER 5700 SERIES, 84924	MOS-3-NS	27/29
CORBIN RUSSWIN 57A1-6 PIN	57A1-6-NS	9/24	MOSLER SAFE DEPOSIT NO. 72732, 73970 (3300 SERIES)	MOS-4-NS	27/29
CORBIN RUSSWIN 57A2-6 PIN	57A2-6-NS	9/24	MOSLER SAFE DEPOSIT NO. 73737	MOS-5-NS	27/29
CORBIN RUSSWIN 57B1-6 PIN	57B1-6-NS	9/24	MUL-T-LOCK® 06	MTL-06-NS	14/25
CORBIN RUSSWIN 57B2-6 PIN	57B2-6-NS	9/24	S&G 4100 Series, Renter & Guard,	S&G-1-NS	27/29
CORBIN RUSSWIN 59A1-6 PIN	59A1-6-NS	9/24	4140, 4120, 4162, 4163, S&G 89		
CORBIN RUSSWIN 59A2-6 PIN	59A2-6-NS	9/24	S&G 4440, 4500, Renter, Precision,	S&G-3-NS	27/29
CORBIN RUSSWIN 59B1-6 PIN	59B1-6-NS	9/24	P40, P5400, S&G 96		
CORBIN RUSSWIN 59B2-6 PIN	59B2-6-NS	9/24	S&G 4442, 4443, Renter, Precision,	S&G-2-NS	27/29
CORBIN RUSSWIN 59C1-6 PIN	59C1-6-NS	9/24	P42, P42Y, P43, S&G 60		
CORBIN RUSSWIN 59C2-6 PIN	59C2-6-NS	9/24	SARGENT 275LE 5 PIN	275LE-NS	15/25
CORBIN RUSSWIN 59D1-6 PIN	59D1-6-NS	9/24	SARGENT 275RE 5 PIN	275RE-NS	15/25
CORBIN RUSSWIN 59D2-6 PIN	59D2-6-NS	9/24	SARGENT 275RF 5 PIN	275RF-NS	16/25
CORBIN RUSSWIN 60-6 PIN	60-6-NS	9/24	SARGENT 275RG 5 PIN	275RG-NS	16/25
CORBIN RUSSWIN 77-6 PIN	77-6-NS	8/24	SARGENT 627OLD 6 PIN MASTER	627OLD-NS	16/25
CORBIN RUSSWIN D1-6 PIN	D1-6-NS	8/24			

Silver Line - Nickel Silver Key Blanks JET

MANUFACTURER	JET	PAGE	MANUFACTURER	JET	PAGE
SARGENT 6270LH 6 PIN MASTER	6270LH-NS	16/25	SCHLAGE 35-101FF 6 PIN	101-FF-NS	17/26
SARGENT 6270LM 6 PIN MASTER	6270LM-NS	16/25	SCHLAGE 35-101F 6 PIN	101-F-NS	17/26
SARGENT 6270LN 6 PIN MASTER FOR WHOLE L-SERIES	6270LN-NS	16/25	SCHLAGE 35-101FG 6 PIN	101-FG-NS	17/26
SARGENT 6270RD 6 PIN MASTER	6270RD-NS	16/25	SCHLAGE 35-101G (924G) 6 PIN	101-G-NS	17/26
SARGENT 6270RH 6 PIN MASTER	6270RH-NS	16/25	SCHLAGE 35-101H 6 PIN	101-H-NS	17/26
SARGENT 6270RM 6 PIN MASTER	6270RM-NS	16/25	SCHLAGE 35-101L 6 PIN	101-L-NS	17/26
SARGENT 6270RN 6 PIN MASTER FOR WHOLE R-SERIES	6270RN-NS	16/25	YALE 19E1R (3 PIN)	19-NS	19/26
SARGENT 6275LA	6275LA-NS	16/25	YALE RN8-NS (5 PIN)	8-NS	19/26
SARGENT 6275LB	6275LB-NS	16/25	YALE RN11-NS (6 PIN)	11-NS	19/26
SARGENT 6275LC	6275LC-NS	16/25	YALE RN11GA-NS (6 PIN)	11-GA-NS	20/26
SARGENT 6275LE	6275LE-NS	16/25	YALE RN11GB-NS (6 PIN)	11-GB-NS	20/26
SARGENT 6275LF	6275LF-NS	16/25	YALE RN11GC-NS (6 PIN)	11-GC-NS	20/26
SARGENT 6275LG	6275LG-NS	16/25	YALE RN11GD-NS (6 PIN)	11-GD-NS	20/26
SARGENT 6275LJ	6275LJ-NS	16/25	YALE RN11GE-NS (6 PIN)	11-GE-NS	20/26
SARGENT 6275LK	6275LK-NS	16/25	YALE RN11GF-NS (6 PIN)	11-GF-NS	20/26
SARGENT 6275LL	6275LL-NS	16/25	YALE RN11GG-NS (6 PIN)	11-GG-NS	20/26
SARGENT 6275RA	6275RA-NS	16/25	YALE RN11GH-NS (6 PIN)	11-GH-NS	20/26
SARGENT 6275RB	6275RB-NS	16/25	YALE RN11GK-NS (6 PIN)	11-GK-NS	20/26
SARGENT 6275RC	6275RC-NS	16/25	YALE RN11GMK-NS (6 PIN)	11-GMK-NS	20/26
SARGENT 6275RE	6275RE-NS	16/25	YALE RN11SA-NS (6 PIN)	11-SA-NS	20/26
SARGENT 6275RF	6275RF-NS	16/25	YALE RN11SB-NS (6 PIN)	11-SB-NS	20/26
SARGENT 6275RG	6275RG-NS	16/25	YALE RN11SC-NS (6 PIN)	11-SC-NS	20/26
SARGENT 6275RJ	6275RJ-NS	16/25	YALE RN11SD-NS (6 PIN)	11-SD-NS	20/26
SARGENT 6275RK	6275RK-NS	16/25	YALE RN11SE-NS (6 PIN)	11-SE-NS	20/26
SARGENT 6275RL	6275RL-NS	16/25	YALE RN11SF-NS (6 PIN)	11-SF-NS	20/26
SCHLAGE 35-100C (923C) 5 PIN DND	100-C-DD-NS	16/26	YALE RN11SG-NS (6 PIN)	11-SG-NS	20/26
SCHLAGE 35-100C (923C) 5 PIN	100-C-NS	17/26	YALE RN11SH-NS (6 PIN)	11-SH-NS	20/26
SCHLAGE 35-100E 5 PIN	100-E-NS	17/26	YALE RN11SK-NS (6 PIN)	11-SK-NS	20/26
SCHLAGE 35-100F 5 PIN	100-F-NS	17/26	YALE RN11SMK-NS (6 PIN)	11-SMK-NS	20/26
SCHLAGE 35-100L 5 PIN	100-L-NS	17/26	YALE SAFE DEPOSIT	YAL-1-NS	27/29
SCHLAGE 35-101C 6 PIN	101-C-NS	17/26	YALE SAFE DEPOSIT	YAL-2-NS	27/29
SCHLAGE 35-101CE 6 PIN	101-CE-NS	17/26	YALE SAFE DEPOSIT	YAL-3-NS	27/29
SCHLAGE 35-101E 6 PIN	101-E-NS	17/26	YORK SAFE DEPOSIT	YOR-1-NS	27/29
			YORK SAFE DEPOSIT	YOR-2-NS	27/29

Comparative Key Blank Lists JET

COLE	JET	PAGE	COLE	JET	PAGE	COLE	JET	PAGE	COLE	JET	PAGE
NOTE: ALL COLE AND JET PART NUMBERS ARE THE SAME, EXCEPT FOR THE FOLLOWING:											
AM4	AM3	4	CO65	CO87	7	H32	H50	32	NA5	NA6	14
AM6	AM7	4	CO66	CO88	7	H33	H51	32	PA1	EM1	10
AP1	K101	6	CO67	CO97	7	HD83	HD84-NP	37	PA2	EM1R	10
AP2	K102	6	CO90	LO1ABM	7	HD90	HD92-NP	37	PH1	R52	15
AP3	K103	6	CO106	HL1	10	IL8	IL360	11	RO1	D8789	14
AP4	K104	6	DA22	SR1-NP	41	IL9	IL260	11	RO4	D8783	14
AP5	K100M	6	DA26	DA28-NP	41	IN10	IN28	11	RO5	D8789	14
AU8	V37-NP	43	DE7	DE6	9	IN21	IN18	11	RO7	D8784	14
BM3	BMW3-NP	37	E5	FT38-NP	37/43	IT3	FT37-NP	37/43	RO8	D8783	14
BO1	HL2	6	E46	FT46-NP	37/43	IT4	FT38-NP	37/43	RO9	D8785, RO1	14
CG14	KP1	7	E51	FT37-NP	37/43	JA11	DA22-NP	40	RT22	RN24-NP	41
CG15	CG16	6	EO201	L191A	18	JA11	SR1-NP	41	RT30	RN30-NP	41
CG16	CG22	6	EO202	191	18	JA62	TR23-NP	36/42	RU18	RU18 1/2	15
CH6	L6M	6	EO437	FT37-NP	37/43	JA63	TR20-NP	42	RU20	RU45	15
CH8	L6MR	6	EO458	FT38-NP	37/43	JA64	TR25-NP	42	RU21	RU46	15
CO34	57B2-6-NS	9/24	EO466	V28M-NP	42	JA73	DA21-NP	40	S23	6275LB-NS	16/25
CO35	57A1-6-NS	9/24	EO467	V29R-NP	42	JA80	HD70, 71-NP	37	S24	6275LC-NS	16/25
CO44	57B1-6-NS	9/24	EO468	V30-NP	42	M3	M4, 5	13	S25	6275LE-NS	16/25
CO54	CO54 1/2	6	ER2	FT36-NP	37	M13	M19	13	S26	6275LF-NS	16/25
CO63	CO62	7	GE1	V26K-NP	42	M60	M6000	13	S27	6275LG-NS	16/25
			GE11	V28M-NP	42	M70	M7000	13	S28	6275LJ-NS	16/25
			GE12	V29R-NP	42	ME63	MB16-NP	40	S29	6275LK-NS	16/25
			GE30	V30-NP	42	MZ15	MZ13-NP	39	S30	6275LL-NS	16/25

COLE	JET	PAGE	CURTIS	JET	PAGE	CURTIS	JET	PAGE	ESP	JET	PAGE
S43	S68	16	CG41	KP9	7	S28	6275LJ-NS	16/25	NOTE: ALL ESP AND JET PART NUMBERS ARE THE SAME, EXCEPT FOR THE FOLLOWING:		
S44	S69	16	CH6	L6M	6	S29	6275LK-NS	16/25	AP101	K101H-NP	6
S45	6275RA-NS	16/25	CO34	57B2-6-NS	9/24	S30	6275LL-NS	16/25	AP102	K102H-NP	6
S46	6275RB-NS	16/25	CO35	57A1-6-NS	9/24	S50	6275RA-NS	16/25	AP103	K103H-NP	6
S47	6275RC-NS	16/25	CO44	57B1-6-NS	9/24	S51	6275RB-NS	16/25	AP104	K104H-NP	6
S48	6275RE-NS	16/25	CO45	57A2-6-NS	9/24	S52	6275RC-NS	16/25	BE2-A	1A1A1-NS	5/24
S49	LO7KMA	16	CO101	CO-KW1	12	S53	6275RE-NS	16/25	BE2-B	1A1B1-NS	5/24
SB11	SAA1-NP	41	CO102	CO99	7	S54	6275RF-NS	16/25	BE2-C	1A1C1-NS	5/24
SC7	SC10	17	CO106	HL1	10	S55	6275RG-NS	16/25	BE2-D	1A1D1-NS	5/24
SC8	101-H-NS	17/26	CO107	CO51	7	S56	6275RJ-NS	16/25	BE2-DD	1A1DD1-NS	5/24
SC11	SC8	17	CO108	CO52	7	S57	6275RK-NS	16/25	BE2-E	1A1E1-NS	5/24
T4	T7	18	D1	KW6	12	S58	6275RL-NS	16/25	BE2-F	1A1F1-NS	5/24
TO20	TR20-NP	42	DA27	DA25-NP	41	SB11	SAA1-NP	41	BE2-G	1A1G1-NS	5/24
TO22	TR23-NP	42	DA27-PH	DA25-PH	47	SC12	101-G-NS	17/26	BE2-H	1A1H1-NS	5/24
TO25	TR25-NP	42	DO3	P54F-NP	9	SC14	101-H-NS	17/26	BE2-I	1A1I1-NS	5/24
TO33	TR33-NP	42	EO201	L191A	18	SC21	101-CE-NS	17/26	BE2-J	1A1J1-NS	5/24
TO39	TR39-NP	42	EO202	191	18	SC24	101-EF-NS	17/26	BE2-K	1A1K1-NS	5/24
TO40	TR40-NP	42	EO203	191B	18	SC26	101-FG-NS	17/26	BE2-L	1A1L1-NS	5/24
TO47	TR47-NP	42	ER1	HR2	10	SK2	057AD-6-NP	8	BE2-M	1A1M1-NS	5/24
VR1	LR191A	18	FT39	FT36-NP	37	SR5	DA25-NP	41	BE2-N	1A1N1-NS	5/24
VR2	L191A	18	HD80	HD82-NP	37	SU7	SUZ11-NP	41	BM3	BMW1-NP	37
VR3	191B	18	HD90	HD91-NP	38	SU17	SUZ17-NP	41	BO1	HL2	6
VR7	191	18	HD90-PH	HD91-PH	46	V26,V27	V26K-NP	42	CG3	CG4	6
VW17	V26K-NP	42	HD91	HD83, 90-NP	38	V28	V28M-NP	42	CO34	57B2-6-NS	9/24
VW23	V30-NP	42	HD91-PH	HD83, 90-PH	46	V29	V29R-NP	42	CO35	57A1-6-NS	9/24
VW24	V28M-NP	42	HD92	HD84, 92-NP	37	V35,V36	V37-NP	43	CO44	57B1-6-NS	9/24
VW25	V29R-NP	42	HY3	HY4-NP	38	VL10	VL8-NP	43	CO45	57A2-6-NS	9/24
VW37	V37-NP	42	HY4	HY5-NP	38	VO1	191	18	CO66	CO88	7
W1	WB1A	18	HY8	HY12-NP	38	W1	WB1A	18	CO106	HL1	10
W2	WB2A	18	HY8-PH	HY12-PH	46	W2	WB2A	18	GAS	B52	30
WK1	WK2	18	HY9	HY13-NP	38	WR4	WR6	18	HD80	HD82-NP	37
WR2	FA1	10	HY9-PH	HY13-PH	46	Y15	Y1E	19	RO1	D8789	14
WR2	WR3	18	IL9	IL360	11	Y79	11-GB-NS	20/26	RO3	D8785	14
WR3	WR5	18	IL10	IL260	11	Y80	11-GC-NS	20/26	RO4	D8783	14
Y79	11-GB-NS	20/26	IN20	IN3	11	Y81	11-GD-NS	20/26	SB11	SAA1-NP	41
Y80	11-GC-NS	20/26	KA16	KA14-NP	39	Y82	11-GE-NS	20/26	SR5	DA25-NP	41
Y81	11-GD-NS	20/26	KA17	KA15-NP	39	Y83	11-GF-NS	20/26	SU17	SUZ17-NP	41
Y82	11-GE-NS	20/26	KA20	YH46-NP	43	Y84	11-GG-NS	20/26	V30F	V30-NP	42
Y83	11-GF-NS	20/26	KA21	YH47-NP	43	Y85	11-GH-NS	20/26	V30R	V30-NP	42
Y84	11-GG-NS	20/26	KA22	YH48/50-NP	43	Y86	11-GK-NS	20/26	V35	V37-NP	43
Y85	11-GH-NS	20/26	KA23	YH49/51-NP	43	Y116	11-SA-NS	20/26	WR4	WR6	18
Y86	11-GK-NS	20/26	KW4	KW1+	12	Y117	11-SB-NS	20/26			
Y107	DC3-NP	31/39/40/41	M15	M1-RV	13	Y118	11-SC-NS	20/26			
Y111	Y227	20	M16	M27	13	Y119	11-SD-NS	20/26			
Y145	Y220	19	MB35	MB16-NP	40	Y120	11-SE-NS	20/26			
			MT1	MIT1-NP	31/40	Y121	11-SF-NS	20/26			
			MIT1-PH	MIT1-PH	44/47	Y122	11-SG-NS	20/26			
			MT3	MIT3-NP	40	Y123	11-SH-NS	20/26			
			MT5	MIT4-NP	31/40	Y124	11-SK-NS	20/26			
			MT5-PH	MIT4-PH	44/47	Y156	Y155V-NP	32			
			MT6	MIT6-NP	40	Y158	Y157V-NP	32			
			MZ14	MZ13-NP	39	Y225	11-SMK-NS	20/26			
			MZ14-PH	MZ13-PH	46	Y234	YAL-1-NS	27/29			
			MZ15	MZ16-NP	39	YM53	YH38-NP	43			
			MZ16	MZ17-NP	40	YM57,SU8	YH46-NP	43			
			MZ18	MZ19-NP	40	YM58,SU9	YH47-NP	43			
			MZ18-PH	MZ19-PH	46	YM59,SU10	YH48/50-NP	43			
			NA17	D8781	14	YM60,SU11	YH49/51-NP	43			
			NA26	NA6	14	YM61,SU12	YH48/50-NP	43			
			PU13	PU1	15	YM62,SU13	YH49/51-NP	43			
			RO1	D8789	14						
			RO3	D8785	14						
			RO4	D8783	14						
			RO5	D8784	14						
			RO7	D8783	14						
			RO11	D8780	14						
			RO12	D8782	14						
			RU44	CO97	7						
			RU51	RU19	15						
			S23	6275LB-NS	16/25						
			S25	6275LE-NS	16/25						
			S25 1/2	275LE-NS	15/25						
			S26	6275LF-NS	16/25						
			S27	6275LG-NS	16/25						

NOTE: ALL CURTIS AND JET PART NUMBERS ARE THE SAME, EXCEPT FOR THE FOLLOWING:

CURTIS	JET	PAGE
215	T146	20
244	YAL-2-NS	27/29
251	T26	20
262	T23	20
AP1	K101	6
AP2	K102	6
AP3	K103	6
AP4	K104	6
AP5	K100M	6
B52	B54-NP	34/39
B70	B65-NP	34/39
BE2	1A1A1-NS	5/24
BE3	1A1B1-NS	5/24
BE4	1A1D1-NS	5/24
BE5	1A1E1-NS	5/24
BE6	1A1C1-NS	5/24
BE7	1A1F1-NS	5/24
BE9	1A1G1-NS	5/24
BE10	1A1H1-NS	5/24
BM3	BMW1-NP	37
BO1	HL2	6
CG17	KP1	6
CG18 1/2	KP2	6

EZ	JET	PAGE	EZ	JET	PAGE	EZ	JET	PAGE	EZ	JET	PAGE	
B49	B49-NP	33	DA23	DA23-NP	40/41	HY16-P	HY16-PH	46	T61F	LUV1	TR23-NP	36/42
B49-P	B49-PH	45	DA24	DA24-NP	40	IL9	IL360	11	TM1	TM300	36	
B50	B50-NP	33	DA25	DA25-NP	41	IL11	IL11-NP	11	TM2	TM400	36	
B50-P	B50-PH	45	DA25-P	DA25-PH	47	KA14	KA14-NP	39	TM3	TM100	36	
B51	B51-NP	33	DA28	DA28-NP	41	KA15	KA15-NP	39	TM4	TM200	36	
B51-P	B51-PH	45	DA31	DA31-NP	41	KK1	KK1-NP	39	TM6	TM700	36	
B52	B52-NP	30	DA31-P	DA31-PH	47	KK2	KK2-NP	39	TM7	TM180	36	
B53	B53-NP	34/39	DA34	DA34-NP	41	KK3	KK3-NP	39	TM8	TM130	36	
B54	B54-NP	34/39	DA34-P	DA34-PH	47	KK4	KK4-NP	39	TM9	TM150	36	
B55	B55-NP	34	DA37	DA37-NP	41	KK5	KK5-NP	39	TM10	TM110	36	
B56	B56-NP	34	DA37-P	DA37-PH	47	KK6-P	HY12-PH	46	TR25	TR25-NP	42	
B59	B59-NP	34	DA38, DA30	DA31-NP	41	KW1	1063KW-BR, -NP	12	TR33	TR33-NP	42	
B61	B61-NP	34	DA38-P, DA30-P	DA31-PH	47	KW1	KW1+, KW1+-NP	12	TR33-P	TR33-PH	47	
B62	B62-NP	34	DA39	DA34-NP	41	KW1	KW1-JET	12	TR37	TR37-NP	42	
B63	B63-NP	34	DA39-P	DA34-PH	47	KW1	KW1-JET-NP	12	TR39	TR39-NP	42	
B64	B64-NP	34	DC1	DC2-NP	31	KW9	KW9-NP	12	TR40	TR40-NP	42	
B65	B65-NP	34/39	DC3	DC3-NP	31/39/40/41	KW10	KW10-NP	12	TR40-P	TR40-PH	47	
B67	B67-NP	34	EZ1	EZ1-NP	13	KW11	KW11-NP	12	TR44	TR44-NP	42	
B68	B68-NP	34	EC7	EC7-NP	32/37	LO1	EA27	9	TR46	TR46-NP	42	
B69	B69-NP	34	ER2	L54G	10	M1	M1+	13	TR47	TR47-NP	42	
B72	B72-NP	34	ET37	FT37-NP	37/43	M14	M19	13	TR47-P	TR47-PH	48	
B74	B74-NP	39	ET38	FT38-NP	37/43	M16	M27	13	TR53	TR53-NP	42	
B76	B76-NP	34	ET46	FT46-NP	37/43	M19	M900	13	V37	V37-NP	43	
B77	B77-NP	35	H50	H50-NP	32	M20	M6000	13	V37-P	V37-PH	48	
B78	B78-NP	35	H51	H51-NP	32	M21	M7000	13	VL6	VL6-NP	43	
B79	B79-NP	35	H54	H54-NP	32	M25	M6000B	14	VL8	VL8-NP	43	
B80	B80-NP	35	H55	H55-NP	32	M26	M7000B	14	VO73S	VL4-NP	43	
B82	B82-NP	35	H56	H56-NP	32	MB16	MB16-NP	40	VR2	L191A	18	
B82-P	B82-PH	45	H59	H59-NP	32	MB41	MB41-NP	40	VR5	191B	18	
B83	B83-NP	35	H60	H60-NP	32	MIT1	MIT1-NP	31/40	VR7	191	18	
B84	B84-NP	35	H62	H62-NP	32	MIT1-P	MIT1-PH	44/47	VR91R	LR191A	18	
B85	B85-NP	35	H62-P	H62-PH	45	MIT3	MIT3-NP	40	VW67	V26K-NP	42	
B86	B86-NP	35	H65	H65-NP	32	MIT4	MIT4-NP	31/40	VW71	V28M-NP	42	
B86-P	B86-PH	45	H65-P	H65-PH	45	MIT4-P	MIT4-PH	44/47	VW71A	V29R-NP	42	
B88	B88-NP	35	H66	H66-NP	33	MIT6	MIT6-NP	40	W1	WB1A	18	
B89	B89-NP	35	H67	H67-NP	33	MIT6-P	MIT6-PH	47	WR3	WR3-NP	18	
B89-P	B89-PH	45	H67-P	H67-PH	45	MZ9	MZ9-NP	39	WR4	WR6	18	
B91	B91-NP	35	H70	H70-NP	33	MZ13	MZ13-NP	39	WR5	P1555-NP, WR5-NP	18	
B91-P	B91-PH	45	H71	H71-NP	33	MZ13-P	MZ13-PH	46	Y1	Y1+, 8-NP, 8-NS	19	
B92	B92-NP	35	H75	H75-NP	33	MZ16	MZ16-NP	39	Y149	Y149-NP	31	
B93	B93-NP	35	H75-P	H75-PH	45	MZ17	MZ17-NP	40	Y152	Y152-NP	31</	

ILCO	JET	PAGE	ILCO	JET	PAGE	ILCO	JET	PAGE	ILCO	JET	PAGE
104AM	K104	6	1010U	S4	16	1092	M1+	13	1186TS-P	H56-PH	44
884BR	MOS-4-NS	27/29	1011	RU1	15	1092-900	M900	13	1190LN	H60	32
885BL	YAL-1-NS	27/29	1011-L4	CR-L4-5	8	1092-6000	M6000	13	1190LN	H60-NP	32
997D_F	Y52	19	1011D1	RU45	15	1092-6000B	M6000B	14	1191ET	H62-NP	32
997D_F	Y52F	19	1011D41	RU19	15	1092-7000	M7000	13	1193FD	H67	33
997EB	Y5	19	1011P	RU4	15	1092-7000B	M7000B	14	1193FD	H67-NP	33
997X	Y6	19	1011PAA	L11P	15	1092B	M2	13	1193MU	H66-NP	33
997X	Y6F	19	1011PZ	RU18	15	1092D	M12	13	1195FD	H71	33
998	Y4	19	1012-60	CR87	8	1092DS	M13	13	1195FD	H71-NP	33
998 (NP)	11-GMK-NS	20/26	1012-D1	CR45	8	1092H	M11	13	1196CM	H78	33
998GA	Y78	19	1014C	HR1	10	1092J	M19	13	1196CM	H78-NP	33
998GA (NP)	11-GA-NP	19	1022	SE1+	17	1092N	M10	13	1196FD	H75	33
998GA (NP)	11-GA-NS	20/26	1022	SE1-JET	17	1092NR	M27	13	1196FD	H75-NP	33
998GB (NP)	11-GB-NS	20/26	1022	SE1-NP	17	1092R	M1-RV	13	1242L	T26	20
998GC (NP)	11-GC-NS	20/26	1022AB	SE8	17	1092TG	M1-TG	11	1270C	T23	20
998GD (NP)	11-GD-NS	20/26	1022H	6SE4	17	1092V	M4	13	1270D	T146	20
998GE (NP)	11-GE-NS	20/26	1022L	RU1	15	1092VM	M5	13	1307A	SC6	17
998GE (NP)	11-GE-NS	20/26	1023	CL1	7	1092VR	M3	13	1307W	SC22	17
998GG (NP)	11-GG-NS	20/26	1028	DIE-3-NS	26/28	1095	YAL-2-NS	27/29	1323	MOS-5-NS	27/29
998GH (NP)	11-GH-NS	20/26	1028AY	YOR-1-NS	27/29	1095HL	YAL-3-NS	27/29	1323L	MOS-2-NS	27/29
998GK (NP)	11-GK-NS	20/26	1028D	YOR-2-NS	27/29	1098DB	B5	30	1333	ILC-1-NS	27/28
998GST	Y227	20	1028L	DIE-1-NS	26/28	1098DB	B5-NP	30	1502	ES8	9/30
998SA (NP)	11-SA-NS	20/26	1028N	HMM-1-NS	26/28	1098GX	B52	30	1502M	ES8M	9
998SB (NP)	11-SB-NS	20/26	1041C	AM1	4	1098GX	B52-NP	30	1503	ES9	9
998SC (NP)	11-SC-NS	20/26	1041E	CG22	6	1098JD	B52, B52-NP	30	1510	BAL-1-NS	4/23
998SD (NP)	11-SD-NS	20/26	1041G	CG1	6	1098M	B1, GAS	30	1515	AIR-5-BR	14
998SE (NP)	11-SE-NS	20/26	1041GA	CG2	6	1098M	B1-NP, GAS-NP	30	1515	AIR-5-NS	14/25
998SF (NP)	11-SF-NS	20/26	1041GR	CG4	6	1098XL	B4	30	1517	SKY-5-NS	14/25
998SG (NP)	11-SG-NS	20/26	1041H	IL1	11	1098XL	B4-NP	30	1522	EZ1-NP	13
998SH (NP)	11-SH-NS	20/26	1041T	CG16	6	1115	MOS-3-NS	27/29	1528	EM1	10
998SK (NP)	11-SK-NS	20/26	1041Y	KP1	7	1120D	SL1	18	1528R	EM1R	10
998SMK (NP)	11-SMK-NS	20/26	1042A	IL510	11	1123	WE1	18	1534	SW1	18
999	Y1+	19	1042B	IL610	11	1133	HMM-2-NS	26/28	1537	CLP1-NP	7
999	Y1M	19	1043B	IL360	11	1137B	137B	4/20/36	1548	E42DN	6
999 (NP)	8-NP	19	1043D	IL260	11	1137S	137S	4/20/36	1550	T3NR	6
999 (NP)	8-NS	19/26	1043J	IL11-NP	11	1141E	T3	18	1551	R55	10
999A	Y2	19	1045	AM6	4	1141GE	T7	18	1556	ES1	9
999A	Y2F	19	1046	AM3	4	1145	100-C-DD-NS	16/26	1573A	CB1-NP	31
999A (NP)	11-NP	19	1052A	DIE-2-NS	26/28	1145	100-C-NP	17	1573B	CB2-NP	31
999A (NP)	11-NS	19/26	1054DI	IN35	11	1145	100-C-NS	17/26	1573C	CB3-NP	31
999B	Y220	19	1054F	IN1	11	1145	SC1	17	1573D	CB4-NP	31
999K1	Y1K-NP	19	1054FN	IN28	11	1145	SC1-DD	16	1573E	CB5-NP	31
999K3	Y2K-NP	19	1054G	54G	10	1145-HA	SC1-RH	58	1573F	CB6-NP	31
999N	Y1E	19	1054K	IN20	11	1145A	101-C-NP	17	1581G	CB7-NP	31
999R	Y1R	19	1054MT	IN33	11	1145A	101-C-NS	17/26	1581H	CB8-NP	31
1000	CO1	7	1054UN	IN29	11	1145A	SC4	17	1589I	CB9-NP	31
1000AB	CO2	7	1054WB	WR3	18	1145A-HA	SC4-RH	58	1589J	CB10-NP	31
1000V	CO26	7	1054WB	WR3-NP	18	1145E	100-E-NS	17/26	1590K	CB11-NP	31
1001	CO5	7	1054WB-HA	WR3-RH	58	1145E	SC8	17	1591L	CB12-NP	31
1001AB	CO6	7	1054WC	FA1	10	1145F	100-F-NS	17/26	1591M	CB13-NP	31
1001ABM	CO90	7	1063B	S&G-2-NS	27/29	1145F	SC7	17	1591N	CB14-NP	31
1001E	CO33	7	1063D	S&G-1-NS	27/29	1145L	100-L-NS	17/26	1591P	CB15-NP	31
1001EA	CO4	7	1063E	S&G-3-NS	27/29	1145L	SC19	17	1597	HK1	10
1001EB	CO3	7	1063KW	1063KW-NP	12	1167FD	H51	32	1598	HK2	10
1001EG	CO36	7	1069E_1069	D8789	14	1167FD	H51-NP	32	1599	HK3	10
1001EH	CO87	7	1069FL	D8787	14	1175N	WK2	18	1600	HK4	10
1001EL	CO37	7	1069G	D8783	14	1176	1063KW-BR	12	1601	TM300	36
1001EN	CO7	7	1069L	NA14	14	1176	1063KW-NP	12	1602	TM400	36
1001GH	CO97	7	1069LA, LB	NA12	14	1176	KW1+	12	1603	TM100	36
1001MA (NP)	57B1-6-NS	9/24	1069LC	NA24	14	1176	KW1+-NP	12	1604	TM200	36
1001MB (NP)	57A2-6-NS	9/24	1069M	D8784	14	1176	KW1-JET	12	1606	TM700	36
1001MK	CO-KW1	12	1069N	D8785	14	1176	KW1-JET-NP	12	1607	TM180	36
1003M	HL1	10	1069S	D8782	14	1176-HA	KW1-RH	58	1608	TM130	36
1004	L1	12	1069W	RO1	15	1176RK	KW9-RT-NP	12	1609	TM150	36
1004A	L4	12	1071	WB1A	18	1177N	NH1	14	1610	TM110	36
1004AL	L5	12	1071A	WB2A	18	1179	AR1	4	1611R	AUT1-NP	30
1004KL	L37	13	1071BD	WB1B	18	1179A	AR4	4	1618	BAU1	5
1007LA	S22 1/2-LA	16	1071BE	WB1C	18	1179A-HA	AR4-RH	58	1646	D4300	14
1007LE	275LE-NS	15/25	1071D	WB2B	18	1180S	XL7	19	1646R	D4301	14
1007RE	275RE-NS	15/25	1071E	WB2C	18	1184FD	H54	32	1793V	Y155V-NP	32
1007RF	275RF-NS	16/25	1079	K1	12	1184FD	H54-NP	32	1794V	Y157V-NP	32
1007RG	275RG-NS	16/25	1079B	K2	12	1185FD	H55	32	1866-13	PU1	15
1009	S1	16	1091	MOS-1-NS	27/29	1185FD	H55-NP	32	1970AM	RA4	30
1010N	S68	16	1092	M1	13	1186TS	H56-NP	32	1970AM	RA4-NP	30

ILCO	JET	PAGE	ILCO	JET	PAGE	ILCO	JET	PAGE	ILCO	JET	PAGE	ILCO	JET	PAGE
6275LA	6275LA-NS	16/25	A1114M	1A1M1-NS	5/24	DW05RT5	DW47R-N-PHT	49	MZ19-P	MZ19-PH	46			
A1	R52	15	A1114Q	1A1O1-NS	5/24	DW05T5	DW47-N-PHT	49	MZ27-P	MZ27-PH	47			
A2	R52L	15	A1114R	1A1R1-NS	5/24	F44/NE9	FT36-NP	37	N1007KMA	6270LN-NS	16/25			
A3	R55	10	A1114TB	1A1TB1-NS	5/24	ET37	FT37-NP	37/43	N1007KMA	S6	16			
A192	A192-NP	13	A1145CE	101-CE-NS	5/24	ET38	FT38-NP	37/43	N1007KMB	S16	16			
A1001ABM	CO89	7	A1145E	101-E-NP	17	H62-P	H62-PH	45	N1007KMC	L07KMA	16			
A1001AH	CO91	7	A1145E	101-E-NS	17/26	H65-P	H65-PH	45	N1007RMA	S31	16			
A1001BH	CO94	7	A1145E	SC9	17	H67-P	H67-PH	45	N1007RMA	6270RN-NS	16/25			
A1001C1	CO98	7	A1145E-HA	SC9-RH	58	H72-EK	H72-N-PHT	50	N1007RMB	S32	16			
A1001C2	CO99	7	A1145EF	101-EF-NS	17/26	H72-PT	H72-PHT	49	N1011M/P/S/T	RU21	15			
A1001D1	CO51	7	A1145F	101-F-NS	17/26	H72-PT-CLEAR	H72-PHT-T	50	N1011P	RU4	15			
A1001D2	CO52	7	A1145F	SC10	17	H73-PT	H73-PHT	50	N1054WB	P1555-NP	18			
A1001DH	CO95	7	A1145FG	101-FG-NS	17/26	H74-PT	H74-PHT	50	N1054WB	WR5	18			
A1001EH	CO88	7	A1145G	101-G-NS	17/26	H75-P	H75-PH	45	N1054WB	WR5-NP	18			
A1001FH	CO92	7	A1145H	101-H-NS	17/26	H76-P	H76-PH	45	N1179A	AR3	4			
A1001GRM	059AD-6	8	A1145I	101-I-NS	17/26	H84-EK	H90-N-PHT	50	NE9_F44	FT36-NP	37			
A1011-L1	L1-6-NS	8/24	A1145L	SC20	17	H86-PT	H86-PHT	50	N101-EK	DA34-N-PHT	53			
A1011-L2	L2-6-NS	8/24	A1176	KW5	12	H1098LA	B10	33	N101T, N102T	DA34-PHT	53			
A1011-L3	L3-6-NS	8/24	A1176KT	KW11	12	H1098LA	B10-NP	33	N104T	DA40-PHT	53			
A1011-L4	CR-L4-6	8	A1176KT	KW11-NP	12	H1098M	B2	30	NSN11T2	DA31-N-PHT	53			
A1011-L4	L4-6-NS	8/24	A1176ST	KW10	12	H1098M	B2-NP	30	Q997E	Y54F	19			
A1011-L12	L12-6-NS	8/24	A1176ST	KW10-NP	12	HD83_90-P	HD83_90-PH	46	Q997E	Y54E	19			
A1011-L34	L34-6-NS	8/24	A1176T	KW9	12	HD91-P	HD91-PH	46	Q1007LA	S22_LA	16			
A1011-L41	CR-L41-6	8	A1176T	KW9-NP	12	HD103-P	HD103-PH	46	Q1007LA	6275LA-NS	16/25			
A1011-L41	L41-6-NS	8/24	A1515	AIR-6-BR	14	HD106-PT	HD106-N-PHT	51	Q1007LB	6275LB-NS	16/25			
A1011D1	RU46	15	A1515	AIR-6-NS	14/25	HD106-PT5	HD106-N-PHT	51	Q1007LC	6275LC-NS	16/25			
A1011D41	RU20	15	A1517	SKY-6-NS	14/25	HD110-P	HD103-PH	46	Q1007LD	6270LD-NS	16/25			
A1011M/P/S/T	RU22	15	AB62C	AB1	4	HO01-PT	HD110-N-PHT	51	Q1007LE	6275LE-NS	16/25			
A1011P	RU16	15	AB62CR	AB2	4	HO01-SVC	HD110-B	51	Q1007LF	6275LF-NS	16/25			
A1011PZ	RU18 1/2	15	AB62E	AB4	4	HO01T5	HD110-N-PHT	51	Q1007LG	6275LG-NS	16/25			
A1012-59A1	59A1-6-NS	9/24	AB62ER	AB3	4	HU46T2	T10HF54-N-PHT	49	Q1007LH	6270LH-NS	16/25			
A1012-59A2	59A2-6-NS	9/24	AG2	A191-NP	13	HU66-P, A-P	HU66VW-PH	48	Q1007LJ	6275LJ-NS	16/25			
A1012-59B1	59B1-6-NS	9/24	B44-P	B44-PH	45	HU66AT2_T5	HU66VW-N-PHT	49	Q1007LK	6275LK-NS	16/25			
A1012-59B2	59B2-6-NS	9/24	B45-P	B45-PH	45	HU66T6, AT6	HU67-PHT	53	Q1007LL					

ILCO	JET	PAGE	ILCO	JET	PAGE	ILCO	JET	PAGE	ILCO	JET	PAGE
P1100	B76-NP	34	S1098WD	B67-NP	34	X140	VL8-NP	43	X1000G	CO10	6
P1101	B84-NP	35	S1098WH	B79-NP	35	X143	B53-NP	34/39	X1014F	EA27	9
P1102	B82	35	S1105	B85-NP	35	X144	BMW3-NP	37	X1014L	EA27	9
P1102	B82-NP	35	S1167FD	H50	32	X145	B55-NP	34	X1054F	IN18	11
P1103	B83	35	S1167FD	H50-NP	32	X146	B56-NP	34	X1054K	IN3	11
P1103	B83-NP	35	S1770U	Y149	31	X147	RN30-NP	41	X1054KF	O4KA	13
P1106	B86	35	S1770U	Y149-NP	31	X151	TR39-NP	42	Y153-P	Y153-PH	44
P1106	B86-NP	35	S1970AM	RA3	30	X152	FT46-NP	37/43	Y154-P	Y154-PH	44
P1107	B89	35	S1970AM	RA3-NP	30	X153	YU1-NP	43	Y155-P	Y155-PH	44
P1107	B89-NP	35	SC1-PC	SC1-PHC	17/22	X154	B54-NP	34/39	Y157-P	Y157-PH	44
P1108	B88-NP	35	SC1041R	KP2	6	X159	TR37-NP	42	Y159-P	Y159-PH	44
P1109	B92	35	SUB1-P	SR8-PH	47	X160	HY2-NP	38	Y160-EK	Y160-N-PHT	49
P1109	B92-NP	35	SX9B (NP)	19-NS	19/26	X162	B59-NP	34	Y160-PT	Y160-PHT	49
P1110	B96-NP	35	SX9B	Y221	20	X165	HD84_92-NP	37	Y162-PT	MIT11-PHT	52
P1111	B91	35	SX1000F	CO17	6	X167	YU2-NP	43	Y164-PT	Y165-PHT	49
P1111	B91-NP	35	T61C	TR20-NP	42	X168	B61-NP	44			
P1112	B93	35	T61C-P	TR20-PH	47	X174	TR40-NP	42			
P1112	B93-NP	35	T61F_P1098V	TR23-NP	36/42	X176	MIT1-NP	31/40			
P1113	B102	36	TE1_TE4	R59	18	X178	MZ16-NP	39			
P1113	B102-NP	36	TE3	HR2	10	X180	B69-NP	34			
P1114	B108-NP	36	TOY40BT4	TR49-PHT	52	X181	HD83_90-NP	38			
P1555	P1555-NP	18	TOY40-EK	TR49-N-PHT	52	X182	HD91-NP	38			
P1577E	KB577E-NS	10/25	TOY43AT4	TR47-PHT	53	X183	HD84_92-NP	37			
P1770U	Y152	31	TOY43-EK	TR47-N-PHT	53	X184	B65-NP	34/39			
P1770U	Y152-NP	31	TOY48BT4	TR48-PHT	52	X186	SUZ17-NP	42			
P1786	Y153	31	TOY48-EK	TR48-N-PHT	52	X187	HY4-NP	38			
P1786	Y153-NP	31	TOY57-PT	TR40-PHT	53	X188	MZ17-NP	40			
P1789	Y154	31	TR25	TR25-NP	42	X192	B72-NP	34			
P1789	Y154-NP	31	TR33-P	TR33-PH	47	X193	HD96-NP	37			
P1793	Y155	31	TR40-P	TR40-PH	47	X195	HD98-NP	38			
P1793	Y155-NP	31	TR47-P	TR47-PH	48	X196	HY5-NP	38			
P1794	Y157	32	V37-P	V37-PH	48	X197	DA31-NP	41			
P1794	Y157-NP	32	VR91	L191A	18	X198	B74-NP	39			
P1795	Y159	32	VR91AR	191	18	X201	MZ19-NP	40			
P1795	Y159-NP	32	VR91B	191B	18	X202	H59-NP	32			
PH32	T32_T32-NP	15	VR91R	LR191A	18	X203	V37-NP	43			
PHA1	R52	15	VW67	V26K-NP	42	X210	DA31-NP	41			
PHA2	R52L	15	VW71	V28M-NP	42	X211	TR44-NP	42			
PR91C	PR7	15	VW71A	V29R-NP	42	X212	TR46-NP	42			
PT04-PT	B107-PHT	50	WR5-PC	WR5-PHC	18/22	X214	HD103-NP	38			
PT04-PT5	B107-N-PHT	50	X6	DA22-NP	40	X216	HY6-NP	38			
PZ1	PZ1	15	X6	SR1-NP	41	X217	TR47-NP	42			
R1001ED (NP)	57B2-6-NS	9/24	X7	DA21-NP	40	X221	H65	32			
R1001EE (NP)	57A1-6-NS	9/24	X9	V30-NP	42	X221	H65-NP	32			
R1001EG (NP)	77-6-NS	8/24	X26	MZ9-NP	39	X222	MZ27-NP	40			
R1001EG	CO62	7	X30	VL4-NP	43	X223	TR53-NP	42			
R1001EL	SK4	7	X52	AAA1-NP	41	X224	MIT3-NP	40			
R1001EM	057AD-6-NP	8	X54	DC2-NP	31	X225	B80-NP	35			
R1001EN	SK1	7	X71	HD70_71-NP	37	X231	H70-NP	33			
R1003M	HL2	6	X77	YH38-NP	43	X232	HY12-NP	38			
R1064E	NA6	14	X80	VL6-NP	43	X233	KK1-NP	39			
S7BW-P	S7BW-PH	48	X82	MB41-NP	40	X235	HY13-NP	38			
S34YS-P	S34YS-PH	48	X84	HD74-NP	38	X236	HY14-NP	38			
S48HF-P	S48HF-PH	48	X86	FC7-NP	32/37	X237	DA34-NP	41			
S50HF-P	S50HF-PH	48	X87	SUZ11-NP	41	X240	KK2-NP	39			
S54F	S54F	9	X88	PA8-NP_V30-NP	42	X242	DA37-NP	41			
S66NN-P	S66NN-PH	48	X103	KA14-NP	39	X243	DA31-NP	41			
S1000V	CO68	7	X106	KA15-NP	39	X244	H76	33			
S1041JA	KP9	7	X114	DA24-NP	40	X244	H76-NP	33			
S1042Z	IL210	11	X115	DA23-NP	40/41	X245	MIT4-NP	31/40			
S1042ZM	IL210M	11	X116	RN24-NP	41	X249	MZ31-NP	40			
S1042ZP	IL210	11	X117	YH48/50-NP	43	X251	SR8-NP	41			
S1042ZS	IL220	11	X118	YH49/51-NP	43	X253	KK3-NP	39			
S1069G	D8780	14	X119	YH47-NP	43	X254	YH46-NP	43			
S1069M	D8781	14	X120	YH46-NP	43	X255	YH47-NP	43			
S1098B	B49	33	X121	DC3-NP	31/39/40/41	X256	YH48/50-NP	43			
S1098B	B49-NP	33	X123	DA25-NP	41	X257	YH49/51-NP	43			
S1098D	B51	33	X124	DA28-NP	41	X263	MIT6-NP	40			
S1098D	B51-NP	33	X128	HD83_90-NP	38	X267	KK4-NP	39			
S1098H	B45	33	X129	HD82-NP	37	X268	DA34-NP	41			
S1098H	B45-NP	33	X131	MZ13-NP	39	X269	KK5-NP	39			
S1098K	B47	33	X137	TR33-NP	42	X1000F	CO19	6			
S1098K	B47-NP	33	X138	HD75-NP	38	X1000ER	CO54_1/2	6			

ILCO	JET	PAGE
X1000G	CO10	6
X1014F	EA27	9
X1014L	EA27	9
X1054F	IN18	11
X1054K	IN3	11
X1054KF	O4KA	13
Y153-P	Y153-PH	44
Y154-P	Y154-PH	44
Y155-P	Y155-PH	44
Y157-P	Y157-PH	44
Y159-P	Y159-PH	44
Y160-EK	Y160-N-PHT	49
Y160-PT	Y160-PHT	49
Y162-PT	MIT11-PHT	52
Y164-PT	Y165-PHT	49

STAR	JET	PAGE
4MA2	M2	13
4MA7	M13	13
4YA1	Y220	19
4YA6	Y6	19
5AM1	AM6	4
5AR2	AR1	4
5AU1	HL1	10
5AU2	NA12	14
5BO1	HL2	6
5CG4	KP1	6
5CG5	CG22	6
5CG7	CG16	6
5CL1	CL1	7
5CO1	CO7	7
5CO2	CO3	7
5CO3	CO1	7
5CO4	CO5	7
5CO5	SK1	7
5CO6	CO10	6
5CO11	CO87	7
5CO12	CO90	7
5CO13	CO97	7
5DO2	S54F	9
5DO4	P54F-NP	9
5DE3	DE6	9
5EA1	EA27	9
5ES1	ES9	9
5ET1	FT36-NP	37
5HL1	HL1-M	10
5HR1	HR1	10
5HR2	HR2	10
5IL1	IN1	11
5IL2	IN20	11
5IL4	IN3	11
5IL7	IN18	11
5IL9	IN28	11
5IL11	IN33	11
5JU2	AM3	4
5KE1	K2	12
5KE2	K1	12
5KW1	1063KW-BR	12
5KW1	1063KW-NP	12
5KW1	KW1+	12
5KW1	KW1+-NP	12
5KW1	KW1-JET	12
5KW1	KW1-JET-NP	12
5LO1	L1	14
5MA3	M4	13
5MA4	M5	13
5MA5	M10	13
5MA6	M11	13
5MA7	M12	13
5ME1	AIR-5-BR	14
5ME1	AIR-5-NS	14/25
5ME2	SKY-5-NS	14/25

STAR	JET	PAGE	STAR	JET	PAGE	STAR	JET	PAGE	STAR	JET	PAGE
5NA1	NH1	14	6SA-1A	S22_1A	16	HBR12A	B48-NP	33	SH2	SC6	17
5RQ4N	NA6	14	6SE1	SE8	17	HBR14C	B50	33	SH6	SC22	17
5RP3	RN24-NP	41	6SE4	6SE4	17	HBR14C	B50-NP	33	SL1	SL1	18
5RU1	RU1	15	6SH1	SC4	17	HBR15A	B62	34	SP1	B53-NP	34/39
5RU2	RU4	15	6SH3	SC20	17	HBR15A	B62-NP	34	T23	T23	20
5RU5	RU18	15	6SH4	SC9	17	HBR15C	B63-NP	34	T26	T26	20
5RU7	RU45	15	6SH5	SC10	17	HBR15E	B77-NP	35	T146	T146	20
5RU8	RU19	15	6SH7	101-G-NS	17/26	HFD10	H51	32	TO1	TR20-NP	42
5RU9	RU21	15	6WR2	WR6	18	HFD10	H51-NP	32	TO2	TR25-NP	42
5SA1	S4	16	6YA1	Y2	19	HFD11	H55	32	TO4	TR40-NP	42
5SA2	S1	16	6YA3	Y4	19	HFD11	H55-NP	32	TO37	TR37-NP	42
5SA3	S16	16	6YA6	Y54	19	HFD12	H54	32	TO47	TR47-NP	42
5SA6	S32	16	6YA8	Y227	20	HFD12	H54-NP	32	VW2	V26K-NP	42
5SA7	S68	16	6YA12	Y78	19	HFD12L	H60	32	VW3	V28M-NP	42
5SA-LA	S22_1/2_LA	16	7CH2	L7M	6	HFD12L	H60-NP	32	VW4	V30-NP_PA8-NP	42
5SE1	SE1+	17	7CH4	L7MR	6	HN2-3	HD70_71-NP	37	VW5	V29R-NP	42
5SE1	SE1-JET	17	7CO1	CO37	7	HN5	HD74-NP	38	YJ1	Y12	20/30/36
5SE1	SE1-NP	17	7CO2	CO33	7	HN6	HD82-NP	37	YJ2	Y14	20
5SE1M	SE1-M	18	7CO5	SK4	7	HN7	HD91-NP	38	YJ3	Y11	20/30/36
5SE3	5SE3	17	7CO11	L01EH	7	HN90	HD90-NP	38	YJ4	Y103	20
5SH1	SC1	17	7CO12	L01ABM	7	HN98	HD98-NP	38	YJ5	Y13	20
5SH3	SC19	17	7IL2	L37	13	HPL68	Y152	31			
5SH4	SC8	17	7LO1	L5	12	HPL68	Y152-NP	31			
5SH5	SC7	17	7RU2	L11P	15	HPL73	Y153	31			
5TA2	T3	18	7RU5	L11PZ	15	HPL73	Y153-NP	31			
5TA4	T7	18	7RU7	L11D1	15	HPL89	Y154	31			
5VR1	L191A	18	7RU8	L11D41	15	HPL89	Y154-NP	31			
5VR2	LR191A	18	7SA3	L07KMA	16	HY5	HY5-NP	38			
5VR3	191	18	B15	B15-NS	33	IL5	IN8	11			
5VR4	191B	18	BN1	BN1-NP	5	IL10UN	IN29	11			
5WE1	WE1	18	CB1	CB1-NP	3						

NOTES

Cool Color

Key Ring Accessories



All Cool Color accessories packaged in colorful, eye catching point of sale display box.



KB
BELL KEY RING
8 ASSORTED COLORS
32 PIECES



KCLF
KEY CLIP FLAT
ASSORTED COLORS
100 PIECES



KCL
KEY CLIP
ASSORTED COLORS
100 PIECES



KT
PLASTIC KEY TAG
WITH KEY RING
8 ASSORTED COLORS
200 PIECES



KTS
PLASTIC KEY TAG
WITH METAL SWIVEL
8 ASSORTED COLORS
200 PIECES



KTT
TRANSPARENT
PLASTIC KEY TAG
WITH KEY RING
8 ASSORTED COLORS
100 PIECES



KTTS
TRANSPARENT
PLASTIC KEY TAG
WITH METAL SWIVEL
8 ASSORTED COLORS
100 PIECES



KCGM
KEY CAPS FOR G.M.
ASSORTED COLORS
200 PIECES



KCP
KEY CAPS
ASSORTED COLORS
200 PIECES



KRS SMALL
KRM MEDIUM
KRL LARGE
KEY RING
ASSORTED COLORS
200 PIECES



View Our Complete Line
of Professional Locksmith Hardware at...
www.jetkeys.com

